

# ZIPPER WELDER

## VERTICAL SEAM WELDER FOR FIELD STORAGE TANKS

An easy to use affordable option to increase your  
welding production!

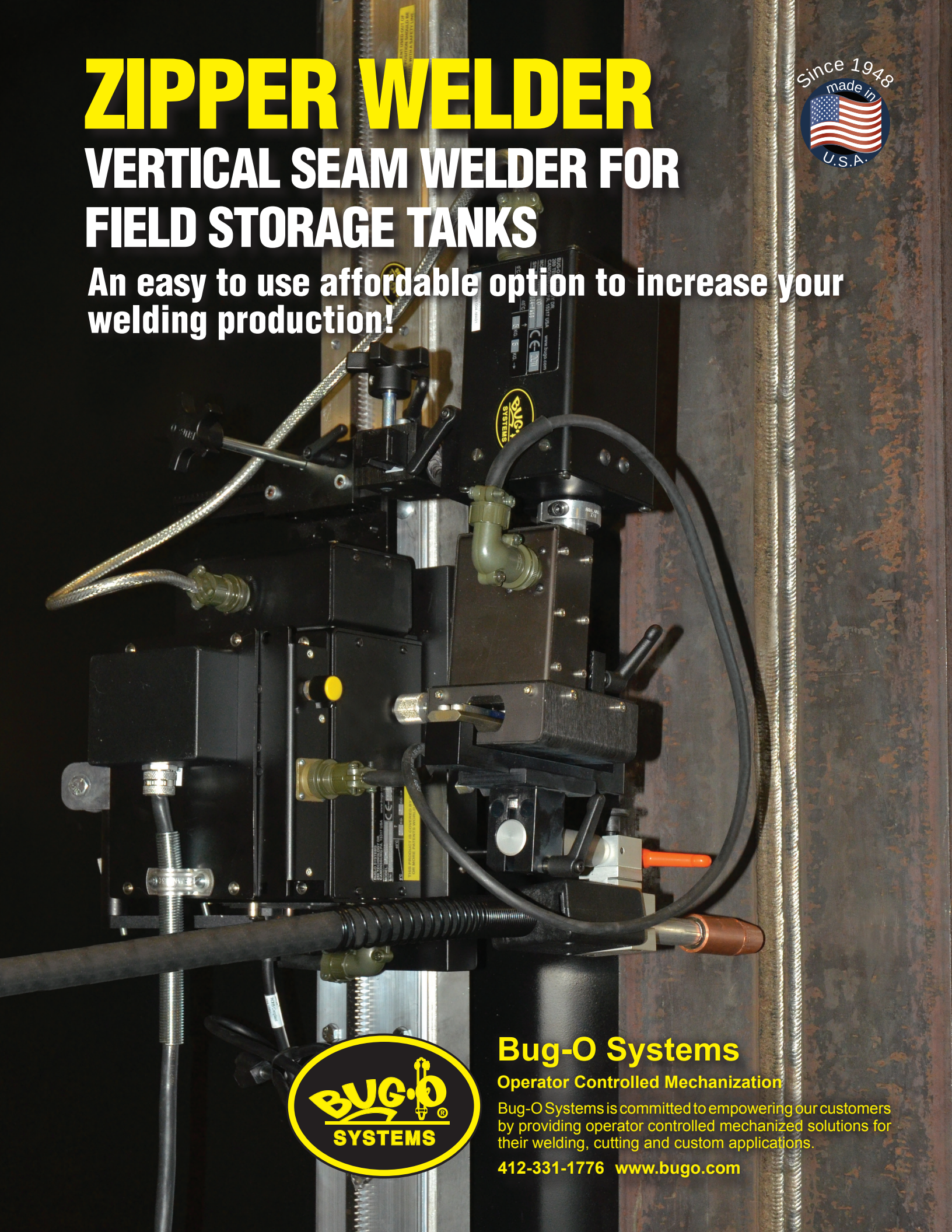

### Bug-O Systems

Operator Controlled Mechanization

Bug-O Systems is committed to empowering our customers by providing operator controlled mechanized solutions for their welding, cutting and custom applications.

412-331-1776 [www.bugo.com](http://www.bugo.com)



# ZIPPER WELDER

The Bug-O Zipper Welder is designed to weld vertical seams on field storage tanks. The system is composed of two standard components: box rail assembly with carriage and the Modular Drive tractor. The box rail assembly with carriage hangs over the top lip of the course section. It can be rolled into position and is held there by powerful on/off magnets. There are box rails available for 8' seams and 10' seams. The Zipper Welder utilizes the Modular Drive tractor and offers systems setup with a pendulum or linear weavers. There is also an optional Automatic Torch Height Control System available for each unit.



## Weaver Control Module

The Weaver Control Module operates the Pendulum or Linear Weaver, and the Master Drive Unit. The Control Module features include: a digital readout and control knob for longitudinal travel speed; a switch for Forward/Stop/Reverse tractor control; an amplitude knob to set weave width from 1/8"-2" (3-50 mm); weave speed control up to 100 in/min (254 cm/min); controls for left and right dwell; a knob to control steering up to 4" (100 mm), either side of center; weld contact; and a power On/Off switch. One of four weld patterns can be chosen using the mode selector switch, as shown in the figure below.

### MDS-1005 Weaver Control Module

Digital display can be set to in/min or cm/min.

- |                        |                         |
|------------------------|-------------------------|
| A- WEAVE SPEED         | G- MODE SELECTOR SWITCH |
| B- DWELL LEFT          | H- AMPLITUDE            |
| C- SPEED CONTROL       | I- DWELL RIGHT          |
| D- POWER OFF-ON SWITCH | J- DIRECTION SWITCH     |
| E- DIGITAL READOUT     | K- WELD CONTACT         |
| F- STEERING CONTROL    |                         |



## BUG-5890 Zipper Welder with Linear Weaver

The photo below shows the drive unit that is supplied with the Zipper Welder w/ Linear Weaver. The Linear Weaver and the Weaver Control Module provide linear weave motion, producing welds from 1/8" to 2" (3-50 mm) wide.

## BUG-5880 Zipper Welder with Pendulum Weaver

The photo below shows the drive unit that is supplied with the Zipper Welder w/ Pendulum Weaver. The Pendulum Weaver and the Weaver Control Module provide pendulum weaving motion.

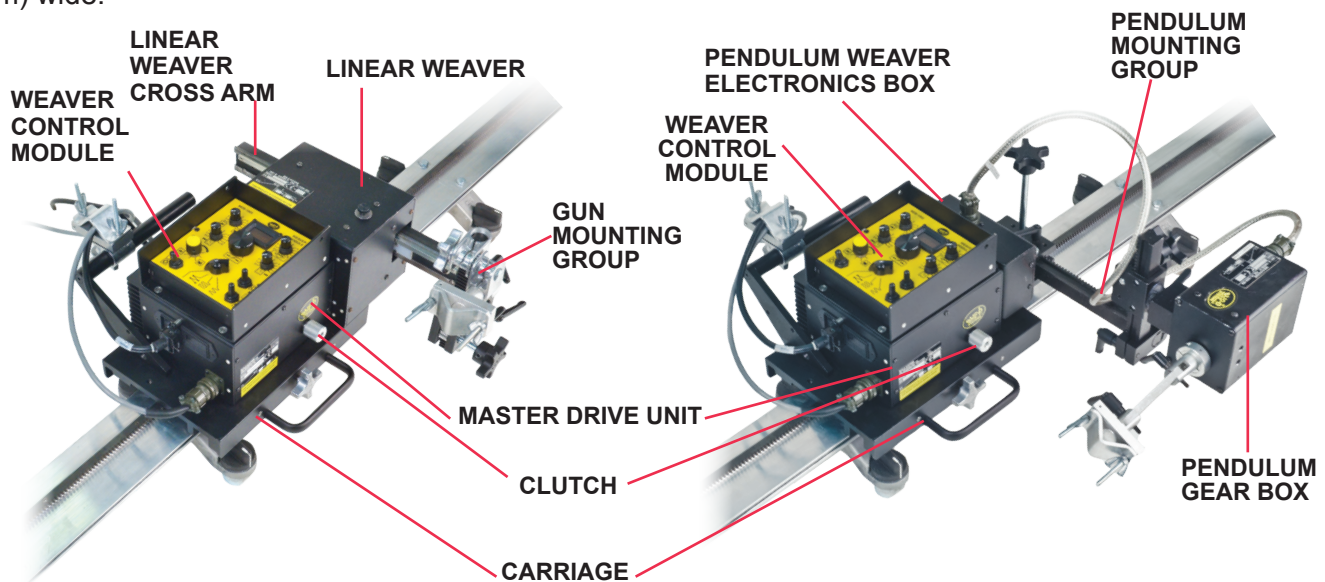



# ZIPPER WELDER

## ZIPPER WELDER WITH PENDULUM WEAVER\*

BUG-5880 (120 VAC)

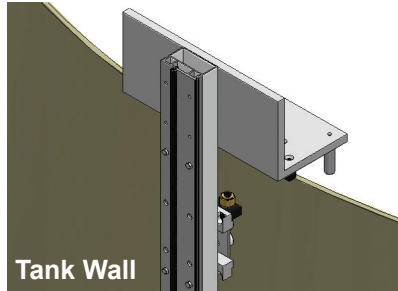
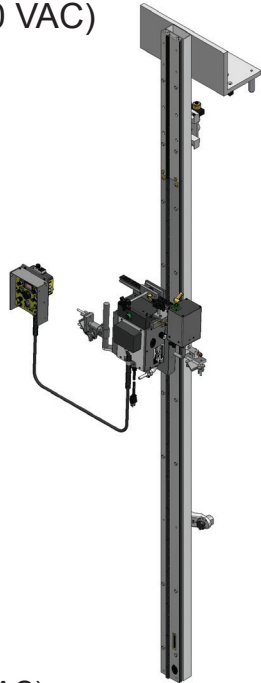

Tank Wall

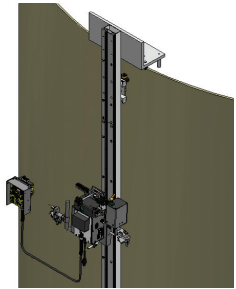

<u>QTY</u>	<u>PART NO.</u>	<u>DESCRIPTION</u>
1	ARR-1180	Box Rail and Support Carriage
1	MDS-1005	Weaver Module
1	MDS-1085-25	Weld Contact Cable 25'
1	MPD-1000	Master Drive Unit 120 Volt
1	MPD-1035	Handle w/Cable Anchor
1	MPD-1065	Releasable Carriage 12"
1	MDS-1060-10	Remote Pendant Cable
1	WPD-2100	Pendulum Weaver

BUG-5882 (240 VAC)

**Same as BUG-5880 except with:**

1	MPD-1002	Master Drive Unit, 240 VAC
---	----------	----------------------------

\*Also available with Auto Height Control: BUG-5880-AHC (120 VAC) or BUG-5882-AHC (240 VAC)

## ZIPPER WELDER WITH LINEAR WEAVER\*

BUG-5890 (120 VAC)

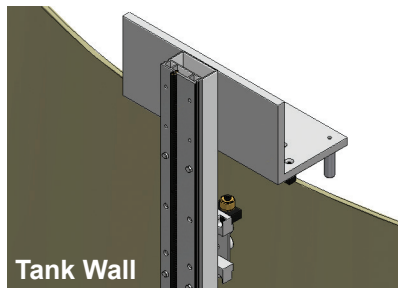
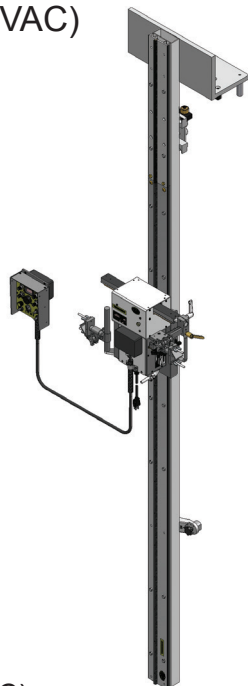

Tank Wall

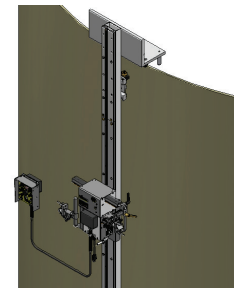

<u>QTY</u>	<u>PART NO.</u>	<u>DESCRIPTION</u>
1	ARR-1180	Box Rail and Support Carriage
1	MDS-1005	Weaver Module
1	MDS-1085-25	Weld Contact Cable 25'
1	MPD-1000	Master Drive Unit, 120 Volt
1	MPD-1035	Handle w/ Cable Anchor
1	MPD-1065	Releasable Carriage 12" (305 mm)
1	MDS-1060-10	Remote Pendant Cable
1	WPD-1100	Linear Weaver

BUG-5892 (240 VAC)

**Same as BUG-5890 except with:**

1	MPD-1002	Master Drive Unit, 240 VAC
---	----------	----------------------------

\*Also available with Auto Height Control: BUG-5890-AHC (120 VAC) or BUG-5892-AHC (240 VAC)



# ZIPPER WELDER



## Box Rail Data:

Shell Plate Height:  
Min. - Max.

ARR-1180	6' - 8' (1.8 - 2.4 m) Standard
ARR-1180-144	6'-10' (1.8 - 3.0 m) Optional

## Technical Data:

Power Requirements:

**PENDULUM WEAVER**  
 BUG-5880 120 VAC/50-60/1  
 BUG-5882 240 VAC/50-60/1

**LINEAR WEAVER**  
 BUG-5890 120 VAC/50-60/1  
 BUG-5892 240 VAC/50-60/1

**Net Weight:** 120 lbs. (54.43 kg)  
**Shipping Weight:** 340 lbs. (154.22 kg)

**Speed:** 2-120 in/min  
 (51-3048 mm/min)

**Vertical Load Capacity:** 60 lbs (27 kg)

### Dimensions of

**Box Rail & Carriage:** **ARR-1180** - 120" (3048 mm) L X 18" (457.2 mm) W X 11" (279 mm) D  
**ARR-1180-144** - 144" (3657.6 mm) L X 18" (457.2 mm) W X 11" (279 mm) D

**Shipping Dimensions:** 128" (3251 mm) X 25" (635 mm) X 30" (762 mm)

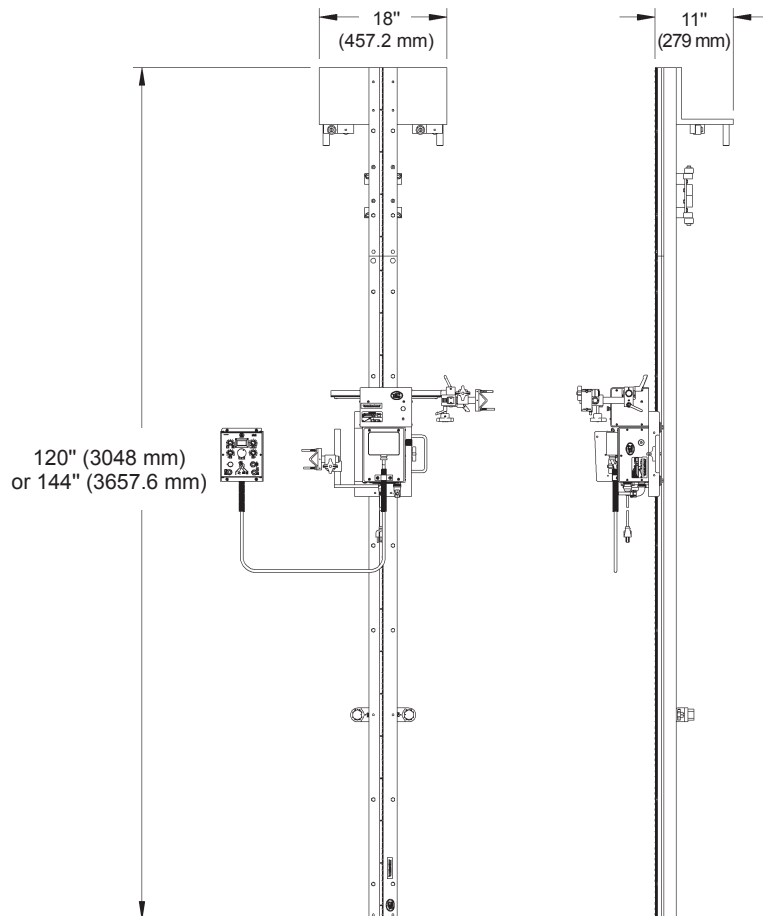

See our Modular Drive System Brochure for additional details of tractor and oscillators.

