

INSTRUCTIONS AND PARTS MANUAL

MODULAR DRIVE SYSTEM

Please record your equipment identification information below for future reference. This information can be found on your machine nameplate.

Model Number: _____

Serial Number: _____

Date of Purchase: _____

Whenever you request replacement parts or information on this equipment, always supply the information you have recorded above.

LIT-MDS-IPM-0326

Bug-O Systems is committed to empowering our customers by providing operator controlled mechanized solutions for their welding, cutting and custom applications.



B U G O S Y S T E M S

A DIVISION OF WELD TOOLING CORPORATION



280 TECHNOLOGY DRIVE CANONSBURG, PENNSYLVANIA 15317-9564 USA
PHONE: 412-331-1776 <https://www.bugo.com> FAX: 412-331-0383

SAFETY

PROTECT YOURSELF AND OTHERS FROM SERIOUS INJURY OR DEATH. KEEP CHILDREN AWAY. BE SURE THAT ALL INSTALLATION, OPERATION, MAINTENANCE AND REPAIR PROCEDURES ARE PERFORMED ONLY BY QUALIFIED INDIVIDUALS.



ELECTRIC SHOCK can kill.

- 1) The equipment is not waterproof. Using the unit in a wet environment may result in serious injury. Do not touch equipment when wet or standing in a wet location.
- 2) The unused connectors have power on them. Always keep the unused connectors covered with the supplied protective panels. Operation of the machine without the protective panels may result in injury.
- 3) Never open the equipment without first unplugging the power cord or serious injury may result.
- 4) Verify the customer-supplied power connections are made in accordance with all applicable local and national electrical safety codes. If none exist, use International Electric Code (IEC) 950.
- 5) Never remove or bypass the equipment power cord ground. Verify the equipment is grounded in accordance with all applicable local and national electrical safety codes. If none exist, use International Electric Code (IEC) 950.

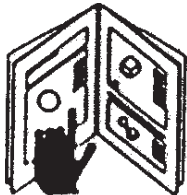

READ INSTRUCTIONS.

Read the instruction manual before installing and using the equipment.



EQUIPMENT DAMAGE POSSIBLE.

- 1) Do not plug in the power cord without first verifying the equipment is OFF and the cord input voltage is the same as required by the machine or serious damage may result.
- 2) Always verify both the pinion and wheels are fully engaged before applying power or equipment damage may occur.
- 3) Do not leave the equipment unattended.
- 4) Remove from the work site and store in a safe location when not in use.



FALLING EQUIPMENT can cause serious personal injury and equipment damage.

Faulty or careless user installation is possible. As a result, never stand or walk underneath equipment.



MOVING PARTS can cause serious injury.

- 1) Never try to stop the pinion from moving except by removing power or by using the STOP control.
- 2) Do not remove any protective panels, covers or guards and operate equipment.

HIGH FREQUENCY WARNINGS

SPECIAL PRECAUTIONS ARE REQUIRED WHEN USING PLASMA, TIG OR ANY WELDING PROCESS THAT USES HIGH FREQUENCY TO STRIKE AN ARC.



WARNING: HIGH FREQUENCY CAN EFFECT MACHINE OPERATION AND THEREFORE, WELD QUALITY.

Read the precautions below before installing and using the equipment.

PRECAUTIONS:

- 1) Some plasma or welding cables are strong sources of high frequency interference. NEVER lay a plasma or welding cable across the controls of the machine.
- 2) Always physically separate the plasma or welding cable leads from the machine cables. For example, the plasma or welding cable leads should NEVER be bundled with a pendant cable or the machine power cord. Maximize the separation between any machine cables and the plasma or welding cables.
- 3) Strictly follow the grounding procedures specified for the plasma or welding unit. NOTE: Some plasma and welding units produce exceptionally large amounts of high frequency noise. They may require a grounding rod be driven into the earth within six feet (2 meters) of the plasma or welding unit to become compatible with an automatic cutting or welding process.
- 4) If the high frequency is produced using a spark gap, adjust the points so the gap is as small as possible. The larger the gap, the higher the voltage and the higher the interference.
- 5) Some plasma or welding units will inject high frequency interference into the AC power line. Use separate power line branches whenever possible to power the plasma or welding source and the machine. Do not plug them into the same outlet box.
- 6) High frequency noise may enter the machine through the plasma or welding supply remote contactor leads. Some plasma and welding sources can produce noise spikes of up to several thousand volts. These sources are not compatible with automated cutting and welding equipment. It is recommended that the remote contactor leads on these plasma or welding sources not be connected to the machine. An alternate solution is to purchase a separate remote contactor isolation box.

MODULAR DRIVE SYSTEM INSTRUCTIONS AND PARTS MANUAL

TABLE OF CONTENTS

PAGE

5.....	Introduction / Standard Features
6.....	Additional Features
7.....	Setup
8.....	Master Drive Unit / Technical Data / Dimensions
9.....	MPD-1000 Master Drive Unit / Exploded View / Parts List
10.....	Master Drive Unit / Wiring Diagram
11.....	AC Power Wiring Diagram / Electrical Component Chart
12.....	Signal Wiring / Parts List
13.....	Modules / Technical Data / Dimensions
14.....	MDS-1002 Straight Module
15-16 ...	MDS-1003 Stitch Module
17.....	MDS-1004 Programmable Module
18-19 ...	MDS-1005 / MDS-1005-DIAL / Weaver Control Modules
20.....	MDS-1005 / MDS-1005-DIAL / Weaver Control Module Replacement Parts
21.....	Digital Readout Calibration
22.....	WPD-1100 Linear Weaver / Introduction / Features
23.....	Linear Weaver / Technical Data / Dimensions
24-25 ...	Linear Weaver / Setup
26.....	WPD-1100 Linear Weaver / Exploded View
27.....	WPD-1100 Linear Weaver / Parts List
28.....	WPD-2100 Pendulum Weaver II / Introduction / Features
29-30 ...	Pendulum Weaver II / Installation / Setup and Alignment
31.....	Pendulum Weaver II / Technical Data / Dimensions
32.....	WPD-2100 Pendulum Weaver II / Exploded View / Parts List
33.....	WPD-2120 Pendulum Weaver II / Electronics / Exploded View / Parts List
34.....	WPD-2115 Pendulum Gear Box / Exploded View
35.....	Weaver Unit / Wiring Diagram
36.....	Carriages
37.....	Detailed Setup
38.....	MDS-1055 Universal Limit Kit
39.....	MDS-1060-__ Remote Control Cable
39.....	CAS-__ Automatic Height Control
40.....	Accessories
41.....	Aluminum Rigid Rail
42.....	Semi Flex Rail
43.....	Hi-Flex Rail
44.....	Standard Magnet Assemblies
45-46	Vacuum Support Kit
47-56	Troubleshooting Guide
57.....	SPK-1000 Modular Drive System 120V Spare Parts Kit / Parts List
57.....	SPK-1002 Modular Drive System 240V Spare Parts Kit / Parts List
58.....	SPK-1004 Modular Drive System 42V Spare Parts Kit / Parts List
59.....	EU Declaration of Conformity
60.....	Warranty

INTRODUCTION

The Modular Drive System is the only product in the industry that allows the user to custom configure one machine for various applications. The system consists of drives, plug-in control modules and carriages that are easily assembled. The modular design allows the operator to quickly upgrade or reconfigure the machine for straight line cutting and welding, stitch welding or weave welding. The system will run in any position using Aluminum Rigid Rail, Aluminum Semi-Flex Rail [with a minimum radius of 15' (4.57 m)], Bent Rigid Rail or Hi-Flex Rail [with a minimum radius of 40" (1 m)].

The straight line cutting and welding configuration consists of a carriage, master drive, racking group and control module. The optional MDS-1060-10 Remote Control Cable can be used to remote the control module.

A number of straight line control modules are available. The MDS-1002 Straight Line Module provides simple direction and speed control for continuous cutting or welding. The MDS-1003 Stitch Module provides a straight line and stitch welding mode with skip time, weld time and crater/puddle buildup time. The MDS-1004 Programmable Stitch Module provides digital display of all stitch welding parameters. The MDS-1004 Stitch Module has closed position feedback so all distances are set in inches or mm as opposed to time and are repeatable. The MDS-1055 Universal Limit Kit adds cycler, stop at limit and rapid return functions to the MDS-1002 and MDS-1003 modules. The MDS-1004 Programmable Module has built in stop at limit and rapid return modes. For more features, see the appropriate pages on each of the modules.

The Master Drive is rated at 60 lbs (27 kg) vertical load. (International Robotics Standards Rating)** The machine is equipped with overload protection.

STANDARD FEATURES

The Master Drive Unit incorporates the following standard internal features:

- High torque, low inertia motor for precise stops and starts.
- Dedicated fail-safe brake with three times the stopping and holding power of the motor.
- Motor overload protection which turns off the motor and engages the brake when excessive load is placed on the machine.
- Closed loop speed control for adjustable and repeatable control of critical welding or cutting parameters.
- Closed loop position control to prevent position creep when the machine stops to perform an operation such as crater fill at the end of a stitch weld.

**The International Robotics Standards Rating requires a minimum of 2:1 continuous-duty safety margin on all power train and electronics components.

ADDITIONAL FEATURES

1. Control Module that is easily removed or changed.
2. Master Power Drive Module that is reconfigurable by the user, for different applications, by adding or changing mating modules and accessories.
3. Clutch, to enable rapid manual repositioning of the carriage anywhere on the track.
4. Wheel engagement knob, which enables placement of the releasable carriage anywhere on the track.
5. Optional cable mounting bar with anchor clamp to keep the welding cables and contact wires away from the work surface.
6. Contactor ON/OFF switch.
7. Power Entry Box with:
 - a) Input Power Fuse
 - b) Machine ON/OFF Switch
 - c) Power Cord Mating Connector
8. Standard Carrying Handle.
9. Digital speed readout for more repeatable welding/cutting.
10. Optional Carrying Handle and Mounting Bar.
11. Remote Weld Contactor Receptacle.

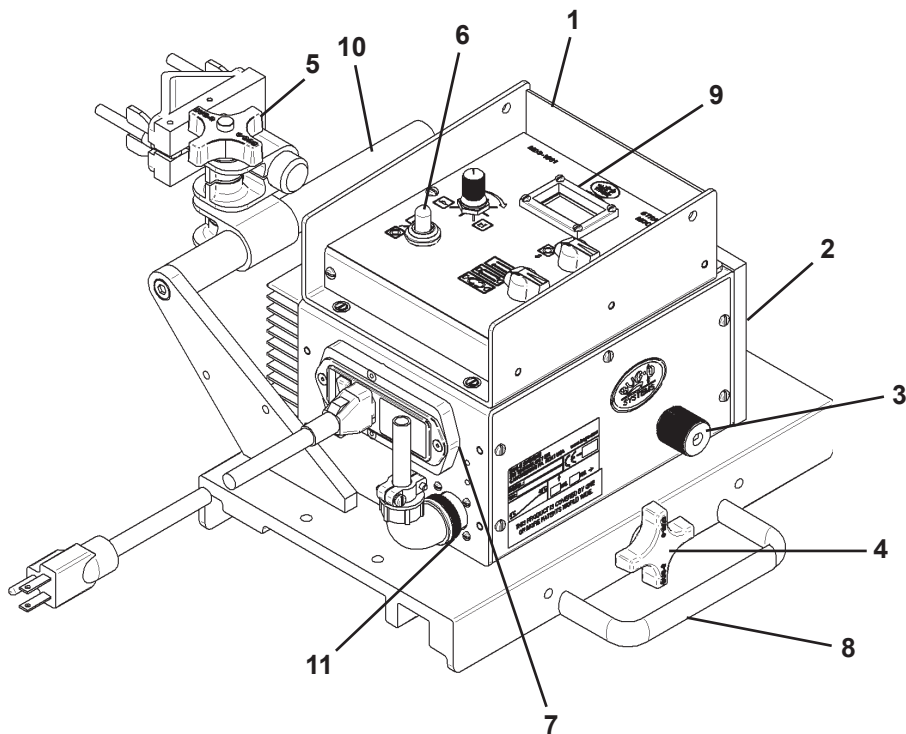

SETUP

1) WHEEL ADJUSTMENT AND ALIGNMENT

Always check for proper carriage wheel adjustment before using the machine. Turn the wheel engagement knob **(A)** on the side of the carriage until the wheels are fully moved towards the center of the carriage (engaged). Then rotate the master drive clutch knob **(B)** fully counter clockwise to disengage the drive pinion. Slide the carriage onto the end of a track. The wheels should slide into the track V-grooves and the carriage will move smoothly along the track if the wheels are properly aligned.

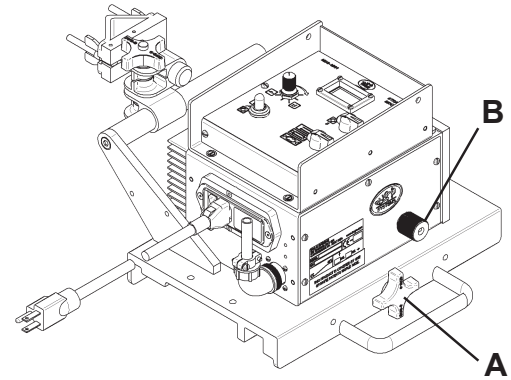

The wheels along one side of the carriage have stainless steel shim washers **(C)** underneath. These wheels are adjustable. Readjust these wheels (if necessary) by rotating the hex bolt **(D)** with a 1/2" wrench.

Grasp the sides of the carriage. The wheels are too loose if it is possible to move the carriage from side to side or up and down. Use a finger to keep one of the adjustable wheels from rotating as the carriage is manually pushed along the track. The wheels are adjusted too tight if firm finger pressure is not enough to prevent wheel rotation. Repeat the process for the other adjustable wheel.

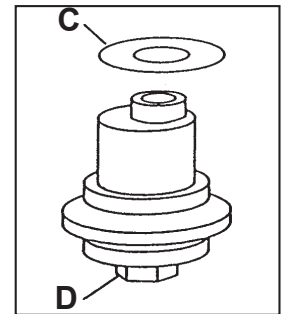

2) POSITIONING THE MACHINE ON THE TRACK

Position the rail using magnet plates or vacuum cups. Wipe the track grooves free of weld splatter and other debris. This will prevent binding and premature rail and wheel wear. Lubricate the rack using a dry spray, if desired, for extended track life.

Turn the wheel engagement knob **(A)** on the side of the carriage fully counter clockwise to disengage the wheels. Then rotate the Master Drive clutch knob **(B)** fully counter clockwise to disengage the drive pinion. The carriage can now be placed anywhere on the track. Turn the wheel engagement knob **(A)** clockwise to engage the wheels firmly in the V-grooves. Verify all four wheels are in the grooves. Manually move the carriage along the track to verify the motion is smooth and the wheel alignment is correct. Rotate the Master Drive clutch knob **(B)** fully clockwise while gently rocking the machine forward and backward to fully engage the drive pinion. The rocking motion is necessary to help insure proper gear mesh.

3) REMOTE CONTACTOR WIRING

Connect the remote weld contactor on the main drive unit to the welding source as shown below:

- Pins A and B connection for Output #1
- Pins C and D connection for Output #2

4) GUN AND TORCH SETUP

For welding, insert the welding gun into the all-position clamp on the rack. Adjust the clamp, the clamp block and the rack to position the gun for welding. Connect the weld contactor connector to the rear of the main drive unit. Route the welding cable and weld contactor wires through the cable anchor clamp.

For cutting, insert the cutting torch into the torchholder on the rack. Adjust the torchholder, the clamp block and the rack to position the torch for cutting. Connect the hose assembly to the manifold and the cutting torch. The manifold acts as a strain relief on the supply hoses as well as a quick shut-off valve for the gases. Once the torch valves are adjusted, the manifold eliminates the need for continuous adjustments and keeps the supply lines from dragging the torch out of position.

5) MACHINE OPERATION

Turn the main power ON at the power entry box. Set parameters on control module in use.

MASTER DRIVE UNIT / TECHNICAL DATA

Power Requirements:

Part Number	Voltage / Hz	Amps
MPD-1000	120 VAC/50-60 Hz	2A
MPD-1002	240 VAC/50-60 Hz	3A
MPD-1004	42 VAC/50-60 Hz	5A

Dimensions: 7.75" L x 6.00" W x 4.25" H
(197 x 152 x 108 mm)

Load Capacity: Vertical - 60 lbs (27 kg) [International Robotics Standards Rating]**
Horizontal - 100 lbs (45 kg)

Speed Range: 2-120 in/min (51-3048 mm/min)

Net Weight: 10 lbs (4.5 kg)

Shipping Weight: 13 lbs (5.9 kg)

DIMENSIONS

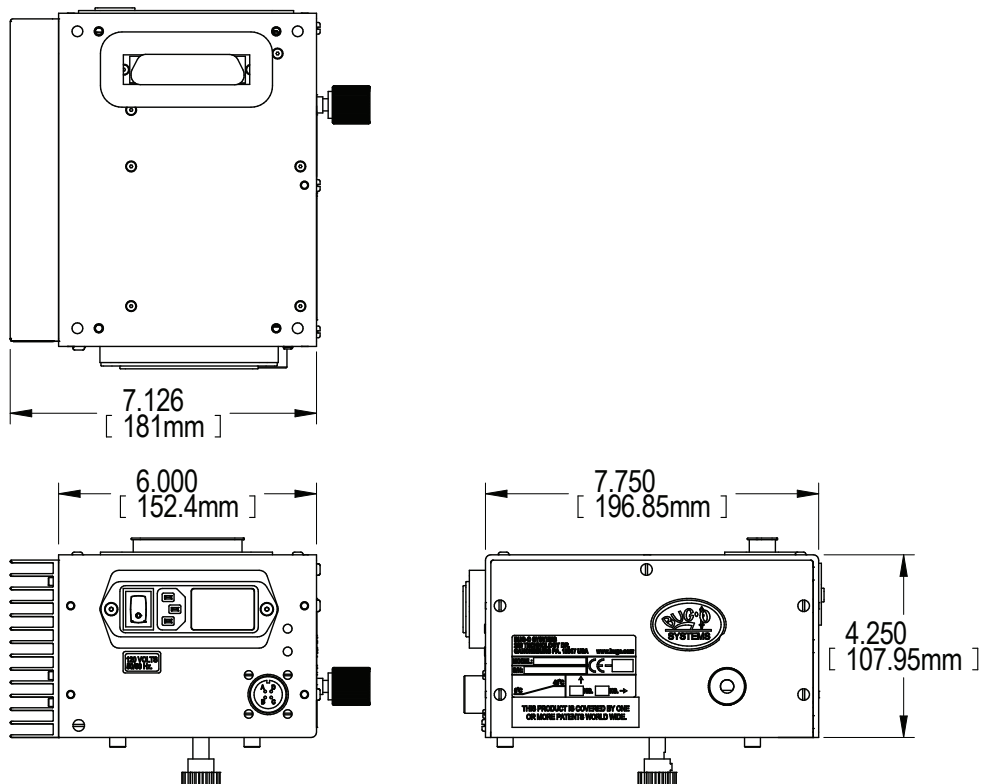

** The Master Drive is rated at 60 lbs (27 kg) vertical load. The International Robotics Standards Rating requires a minimum of 2:1 continuous-duty safety margin on all power train and electronics components. The machine is equipped with overload protection.

CAUTION: The Speed Control Card in the Master Drive is **NOT** interchangeable with the speed card in the Linear or Pendulum Weavers.

MPD-1000 MASTER DRIVE UNIT / EXPLODED VIEW / PARTS LIST

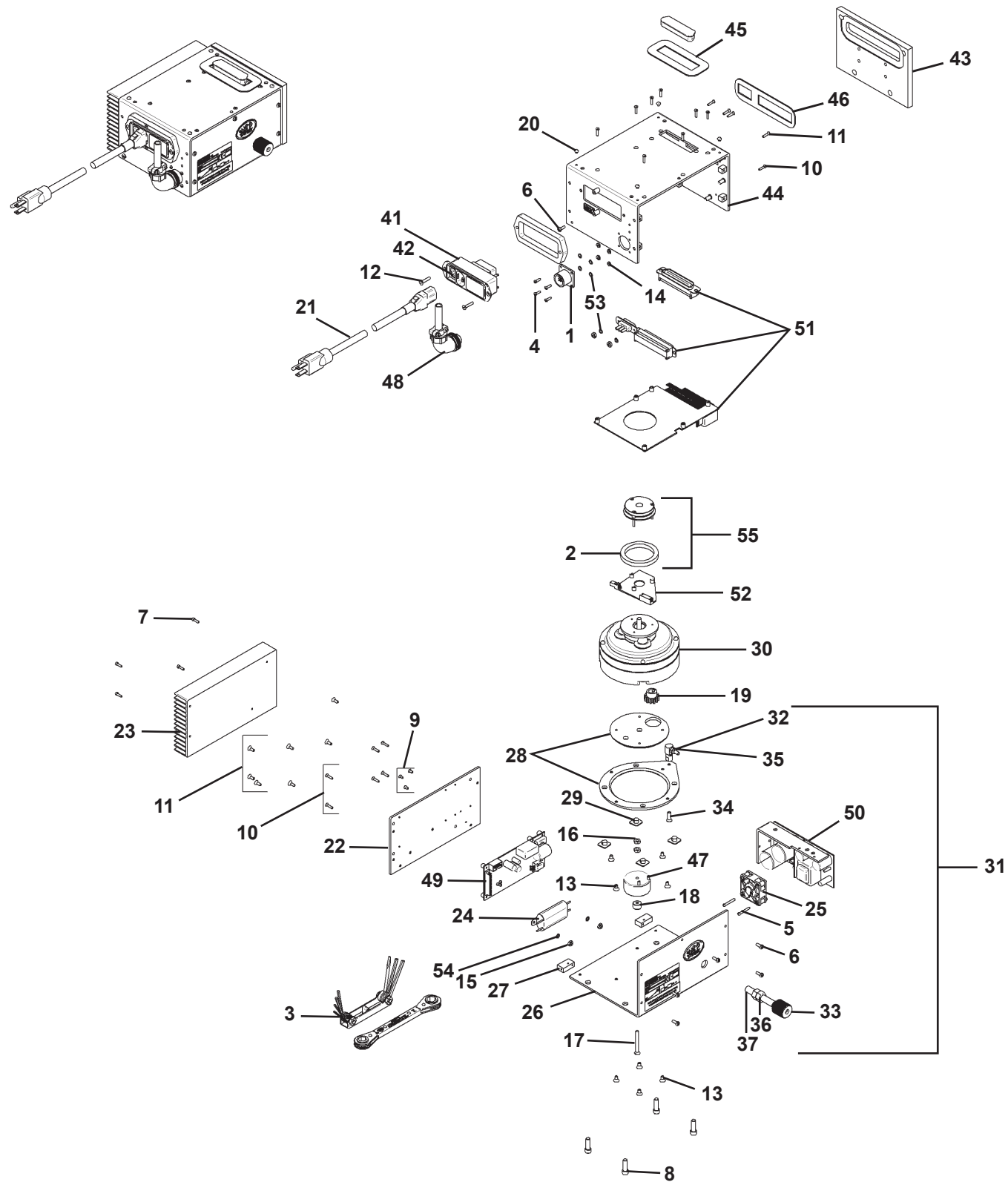

<u>ITEM</u>	<u>QTY</u>	<u>PART NO.</u>	<u>DESCRIPTION</u>
1	1	BUG-1034	Panel Connector, 4-T, Male
2	1	WPD-1013	Rubber Ring Gasket
3	1	BUG-9444	Tool Kit
4	4	FAS-0104	Pan Hd Screw 4-40 x 318 Lg
5	2	FAS-0107	Pan Hd Screw 4-40 x 3/4 Lg
6	6	FAS-0114	Pan Hd Screw 6-32 x 3/8 Lg
7	4	FAS-0504	Soc Hd Cap Scr 4-40 x 3/8 Lg
8	4	FAS-0557	Soc Hd Cap Scr 1/4-20 x 3/4 Lg
9	3	FAS-0902	Flt Hd Soc Scr 4-40 x 1/4 Lg
10	19	FAS-0905	Flt Hd Soc Scr 4-40 x 1/2 Lg
11	10	FAS-0914	Flt Hd Soc Scr 6-32 x 3/8 Lg
12	2	100-0311	Flt Hd Soc Cap Scr 6-32 x 3/4
13	8	FAS-0923	Flt Hd Soc Scr 8-32 x 5/16 Lg
14	6	FAS-1305	Hex Nut 4-40
15	2	FAS-1310	Hex Nut 6-32
16	2	FAS-1325	Hex Nut 8-32 Nylon
17	1	FAS-2823	Flt Hd Sit Scr 8-32 x 1 1/2 Lg
18	1	GOF-3012	Spacer 1/2 OD x 5/16 Lg
19	1	GOF-3014	Pinion
20	4	MDS-1019	Snap Rivet, Black
**21	1	BUG-9454	V-Lock Cord 120VAC
22	1	MPD-1006	Side Panel
23	1	MPD-1007	Heat Sink
24	1	MPD-1008	Filter
25	1	MPD-1009	Fan Assembly
26	1	MPD-1011	Base Panel
27	2	MPD-1012	Mounting Block
28	1	MPD-1090	Matched Clutch Plts
***29	1	BUG-2593	Glide Flat
30	1	MPD-1015	Gear Motor (60:1)
31	1	MPD-1016	Clutch Assembly (Includes items 32 through 37)
32	1	BUG-1216	Ball Joint
33	1	BUG-1857	Knob
34	1	FAS-0945	Flt Hd Soc Scr 10-32 x 1/2 Lg
35	1	FAS-1341	Hex Jam Nut 10-32
36	2	FAS-1390	Hex Nut 3/8-16
37	1	MPD-1017	3/8-16 Threaded Stud
*38	1	MPD-1018	Wiring Harness-Speed Board to Motor
*39	1	MPD-1019	Wiring Harness-Interconnect to Speed Bd/Control
*40	1	WPD-2006	Wiring Harness-Interconnect to Speed Bd/Power
41	1	MPD-1025	Power Entry Module
**42	2	MPD-1058	5A Slo-Blo 5mm x 20mm Fuse
43	1	MPD-1029	Connector Cover Plate
44	1	MPD-1031	Cover Panel (Includes item #20)
45	1	MPD-1038	Gasket for 50-Pin Connector
46	1	MPD-1039	Gasket for 50-Pin/3-Pin Connector
47	1	MPD-1042	Inductor, Potted-with Connectors
48	1	MUG-1617	Cable Connector, 4-T, Female, Elbow
**49	1	PCB-1000	Speed Board
**50	1	PCB-1005-120-240	Power Supply Assembly 165W 120VAC
51	1	PCB-1010	Interconnect Board
52	1	PCB-1012	Position Card
53	6	WAS-0201	#4 Internal Star Lockwasher
54	2	WAS-0211	#6 Internal Star Lockwasher
55	1	WPD-1012	Brake Assembly

* Not Shown

** See Electrical Component Chart for 240 VAC and 42 VAC Part Numbers

*** Included in Item 28.

CAUTION: The Speed Control Card in the Master Drive is NOT interchangeable with the speed card in the Linear or Pendulum Weavers.

MASTER DRIVE WIRING DIAGRAM MPD-1000/ MPD-1002/ MPD-1004

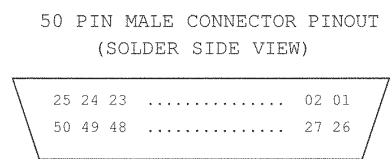
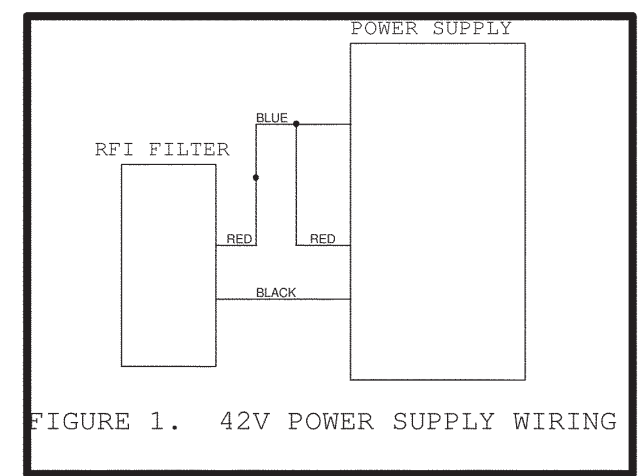
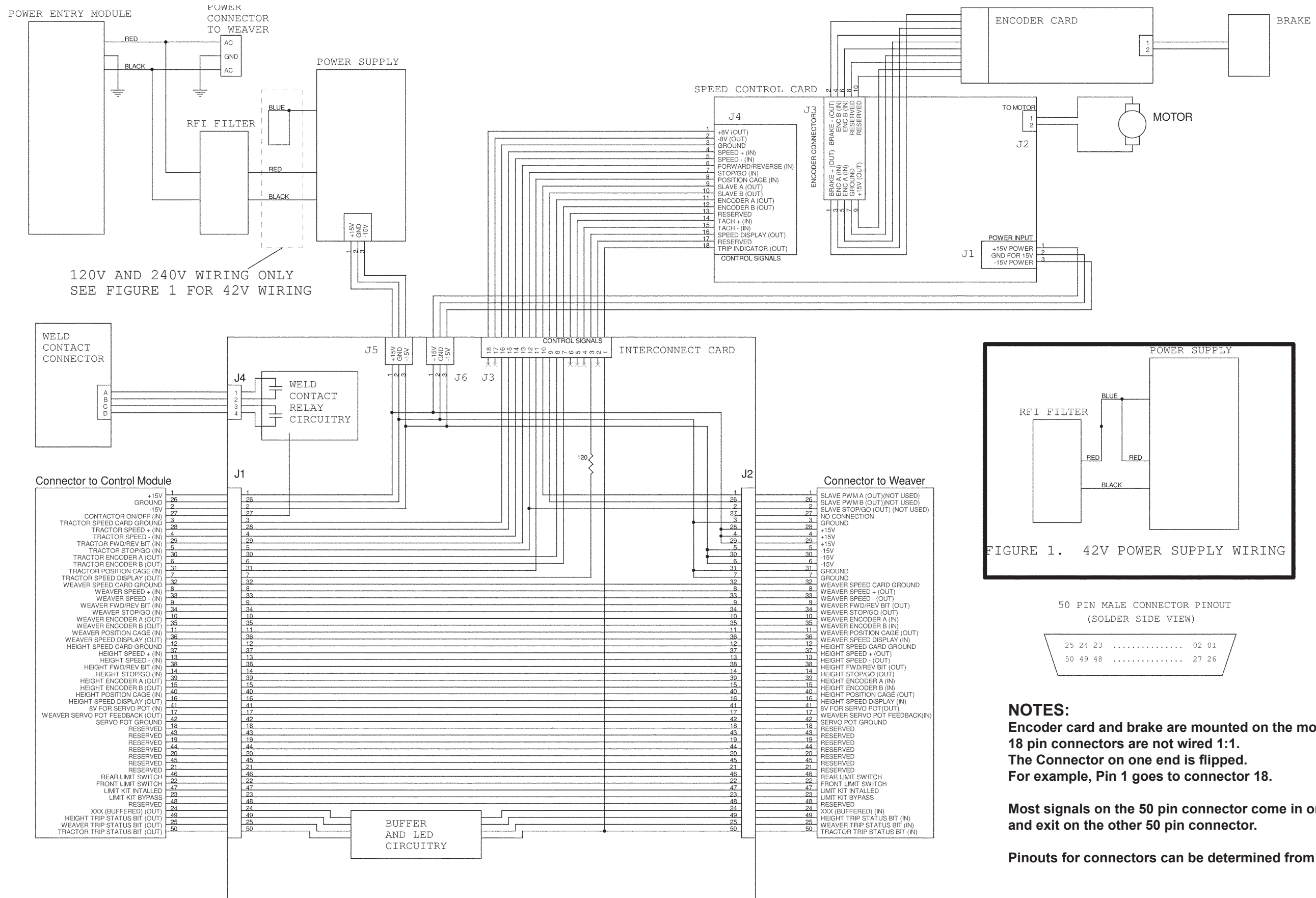

NOTES:
Encoder card and brake are mounted on the motor.
18 pin connectors are not wired 1:1.
The Connector on one end is flipped.
For example, Pin 1 goes to connector 18.

Most signals on the 50 pin connector come in one 50 pin connector and exit on the other 50 pin connector.

Pinouts for connectors can be determined from screen print.

AC POWER WIRING DIAGRAM

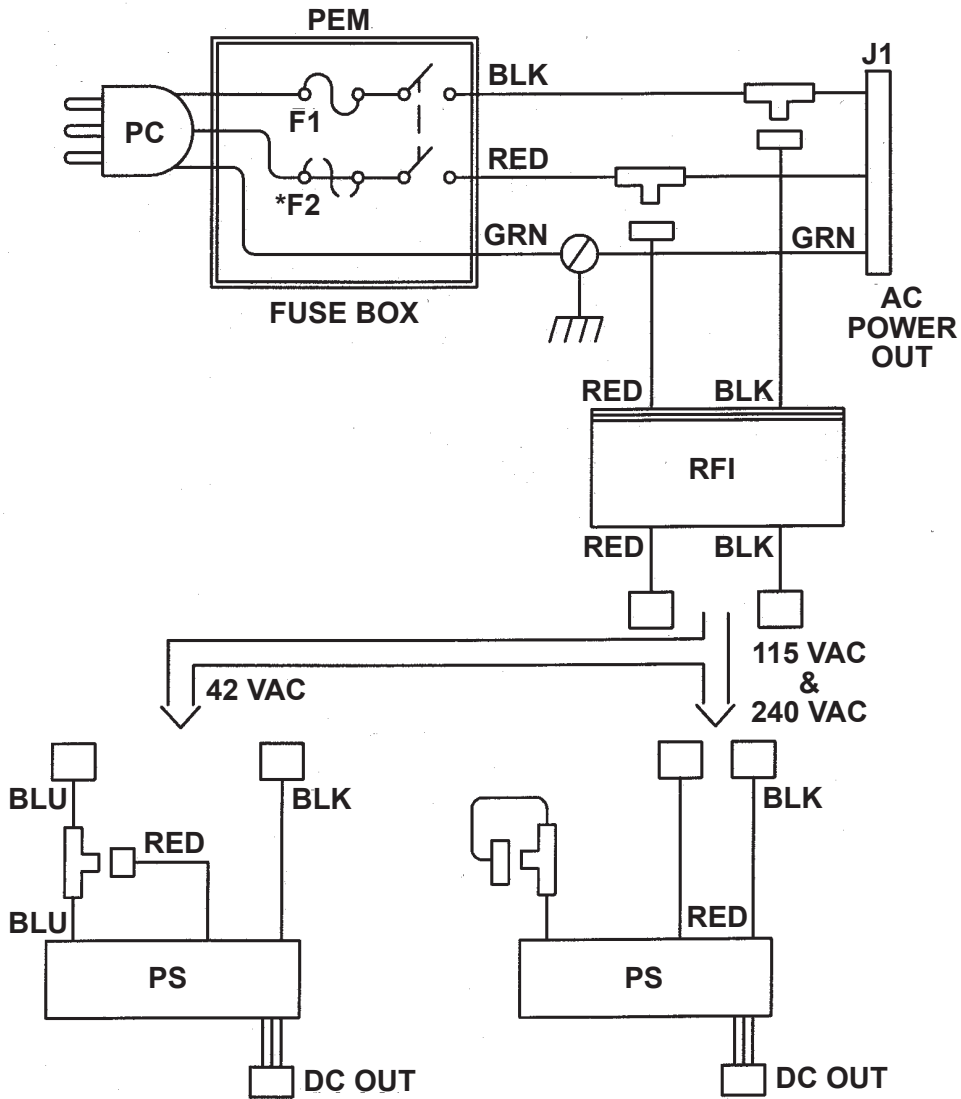

ELECTRICAL COMPONENT CHART

ITEM	DESCRIPTION	PART NO.					
		MPD-1000 120 VAC		MPD-1002 240 VAC		MPD-1004 42 VAC	
F1,F2	Fuses	(2) MPD-1058 5A		(2) MPD-1058 5A		(2) MPD-1058 5A	
PC	Power Cord	New P/N	Old P/N	New P/N	Old P/N	New P/N	Old P/N
		BUG-9454	MPD-1001	BUG-9454-240	MPD-1003	BUG-9454-42	MPD-1005
PS	Power Supply	PCB-1005-120-240		PCB-1005-120-240		PCB-1005-42	
J1	Connector w/Pins	MPD-1021		MPD-1021		MPD-1021	
PEM	Power Entry Module	MPD-1025		MPD-1025		MPD-1025	
RFI	Filter Module	MPD-1008		MPD-1008		MPD-1008	

SIGNAL WIRING

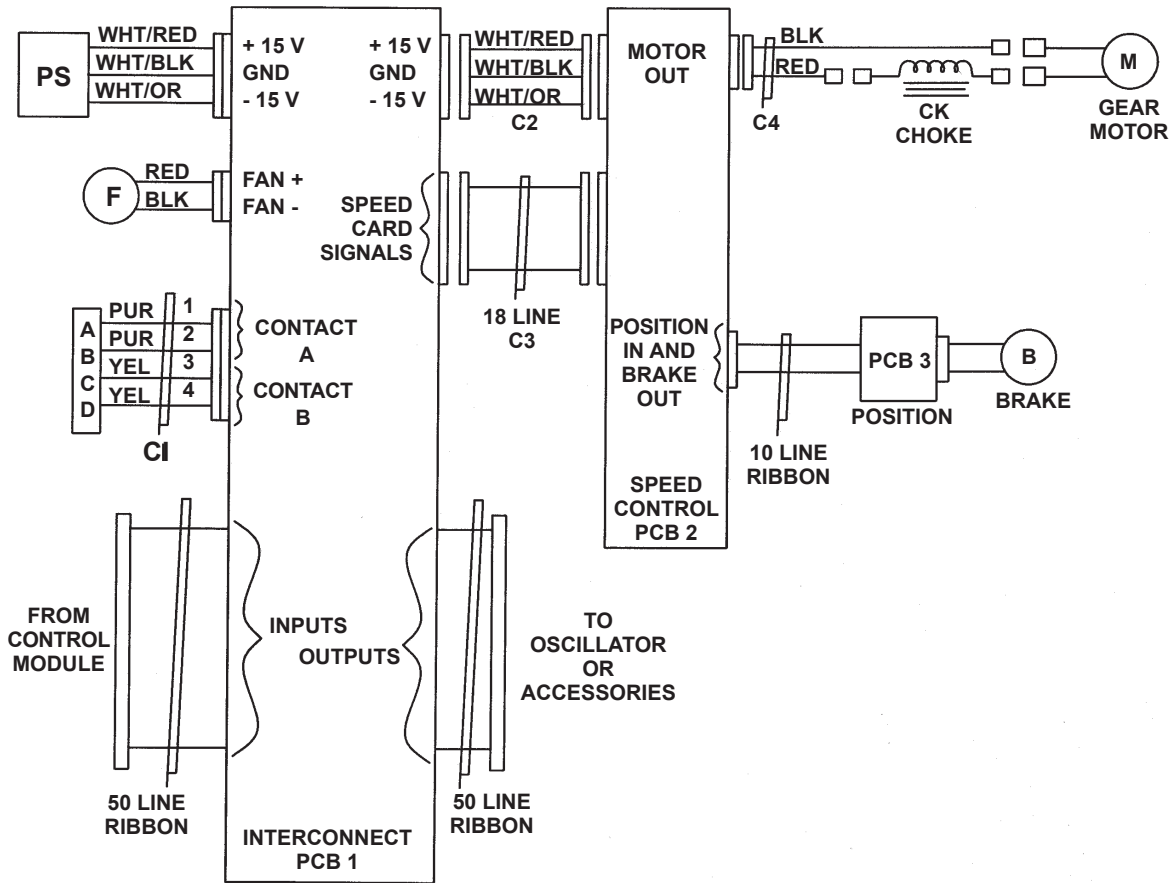

PARTS LIST

ITEM	DESCRIPTION	PART NO.
B	Brake Assembly	WPD-1012
CI	Contacting Cable Assembly	MPD-1036
C2	DC Power Cable Assembly	WPD-2006
C3	Speed Card Cable Assembly	MPD-1019
C4	Motor Wiring	MPD-1018
CK	Inductor Pot Assembly (Choke)	MPD-1042
F	Fan Assembly	MPD-1009
M	Gear Motor	MPD-1015
PCB1	Interconnect Card	PCB-1010
PCB2	Tractor Speed Card	PCB-1000
PCB3	Position Sensor Card	PCB-1012
PS	Power Supply	(see AC Wiring Diagram)

MODULES / TECHNICAL DATA

- MDS-1002 STRAIGHT LINE MODULE
- MDS-1003 STITCH MODULE
- MDS-1004 PROGRAMMABLE MODULE
- MDS-1005 WEAVER CONTROL MODULE

Dimensions: 7.50" L x 6.00" W x 2.50" H
(191 x 152 x 64 mm)

Net Weight: 1.75 lbs (0.8 kg)

Shipping Weight: 3.0 lbs (1.4 kg)

DIMENSIONS

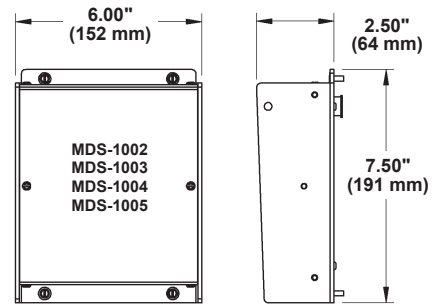

MDS-1005-DIAL WEAVER CONTROL MODULE

Dimensions: 7.50" L x 6.00" W x 3.38" H
(191 x 152 x 86 mm)

Net Weight: 3 lbs (1.4 kg)

Shipping Weight: 8 lbs (3.63 kg)

Dial Weaver Control Module

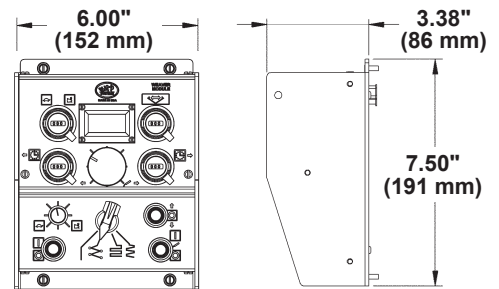

MDS-1002 STRAIGHT MODULE

The MDS-1002 Straight Module provides direction and speed control for continuous cutting or welding.

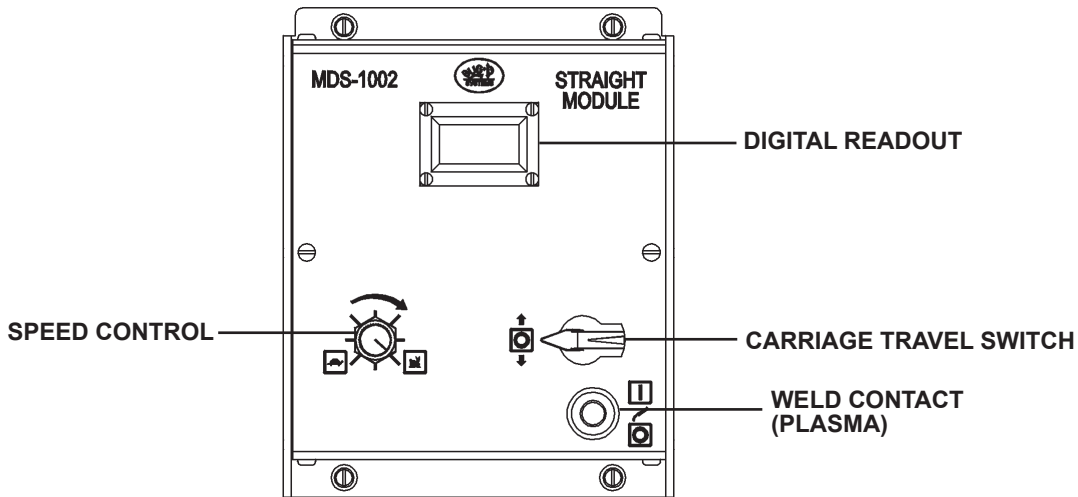

SPEED CONTROL: Sets the tractor speed from 2-120 in/min (5.1-304.8 cm/min).

CARRIAGE TRAVEL SWITCH: Provides **FORWARD/STOP/REVERSE** direction control.
Stop at limit in direction of travel & Cycle between limits can be controlled with the installation of the MDS-1055 Universal Limit Kit. (Ref to pg. 38)

DIGITAL READOUT: The display is dual function.

- a) **PRESET SPEED** - Displayed when the **CARRIAGE TRAVEL SWITCH** is **OFF** or motion is halted by a motor overload condition.
- b) **MEASURED SPEED** - Displayed when power is applied to the motor.
 (This will be the same as the Preset Speed.)

Factory settings of 120 Volt machines are set to in/min, 240 and 42 Volt machines are set cm/min.

WELD CONTACT: Opens/closes a pair of independent 1 Amp contacts (pins A & B and C & D) at the weld contactor receptacle.

NOTE: A safety interlock will automatically open the weld contacts if the motor overload protection halts machine motion. Clear the overload by turning the carriage travel switch to **OFF**. Resetting the overload fault will not cause the contacts to automatically reclose. Use the weld contact switch to restart the welder plasma unit after clearing the overload.

REPLACEMENT POTS AND SWITCHES

CARRIAGE TRAVEL:

Switch and Spacer	MDS-1112
Black Pointer Knob	BUG-9694

SPEED CONTROL:

10 K Ω Pot, 3-3/4 turn	PCB-1026
Black Knob	MDS-1018
Knob Seal Nut	MDS-1046

WELD CONTACT:

Switch and Spacer	MDS-1114
Toggle Switch Boot	MDS-1047

MDS-1003 STITCH MODULE

The MDS-1003 Stitch Module provides direction and speed control for continuous welding and cutting. In addition, a stitch welding mode is provided, with adjustments for skip time (welder off), weld on time and puddle buildup/crater fill time.

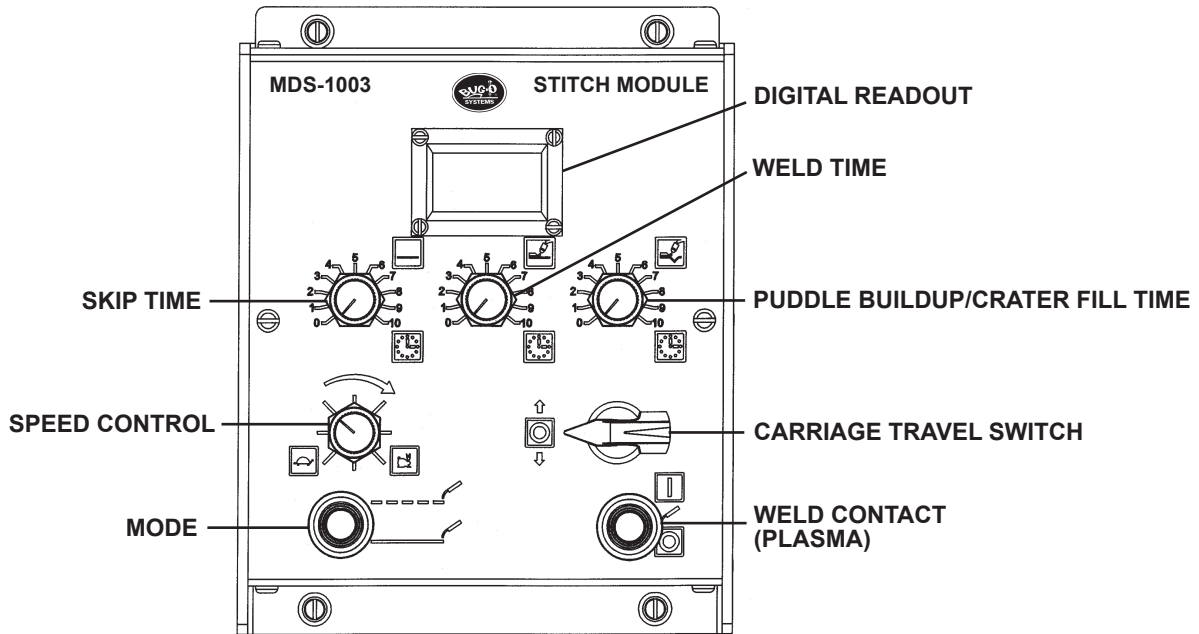

SPEED CONTROL: Sets the tractor weld speed from 2-120 in/min (5.1-304.8 cm/min).

CARRIAGE TRAVEL SWITCH: Provides **FORWARD/STOP/REVERSE** direction control.

DIGITAL READOUT: The display is dual function.

a) **PRESET SPEED** - Displayed when the **CARRIAGE TRAVEL SWITCH** is **OFF** or motion is halted by a motor overload condition.

b) **MEASURED SPEED** - Displayed when power is applied to the motor. (This will be the same as the Preset Speed.)

Factory settings of 120 Volt machines are set to in/min, 240 and 42 Volt machines are set cm/min.

WELD CONTACT: Opens/closes a pair of independent 1 Amp contacts (pins A & B and C & D) at the weld contactor receptacle. In STITCH mode, this switch acts as a weld contact enable and the stitch module cycles the contacts on and off.

NOTE: A safety interlock will automatically open the weld contacts if the motor overload protection halts machine motion. Clear the overload by turning the carriage travel switch to **OFF**. Resetting the overload fault will not cause the contacts to automatically reclose. Use the weld contact switch to restart the welder after clearing the overload.

MDS-1003 STITCH MODULE, CONT'D.

STITCH/CONTINUOUS: Selects between cyclic (Stitch) welding and continuous welding or cutting.

a) **CONTINUOUS** - Selects continuous welding or cutting.

b) **STITCH** - Selects the cyclic (Stitch) welding mode. This mode consists of four continuously repeated steps.

1) The machine stops moving for the selected time to perform **Puddle Buildup. (PIERCE WHEN PLASMA CUTTING)**

2) The machine welds at the selected welding speed for the time selected using the **Weld Time** control.

3) The machine stops moving for the selected time to perform **Crater Fill**.

4) The machine turns off the welder and moves at maximum speed to where the next weld needs performed. This location is determined by setting a **Skip Time** control.

WELD TIME: This control functions only when the mode switch is set to **Stitch**. Weld time sets a weld length time from 1-50 seconds. This corresponds to a weld length of approximately 0.03-100 inches (0.8-2540 mm). **NOTE:** The operator must manually enable the weld contactor by turning on the **Weld Contact** or the welder will never cycle on and off.

SKIP TIME: This control functions only when the mode switch is set to **Stitch**. Skip time sets how long the machine travels between welds (0.3-15 seconds). This corresponds with a skip length of approximately 0.6-30 inches (15-762 mm). The machine always moves between welds at maximum speed.

PUDDLE BUILDUP / CRATER FILL TIME: This control functions only when the mode switch is set to **Stitch**. Puddle Buildup/Crater Fill Time sets the time the machine is stopped at the beginning and end of every weld (0-1.5 sec).

REPLACEMENT POTS AND SWITCHES

WELD CONTACT:

Switch and Spacer	MDS-1116
Toggle Switch Boot	MDS-1047

CARRIAGE TRAVEL SWITCH:

Switch and Spacer	MDS-1112
Black Pointer Knob	BUG-9694

PUDDLE BUILDUP/CRATER FILL TIME:

500K Ω Pot, 3/4 turn	MDS-1053
Black Knob	MDS-1018
Knob Seal Nut	MDS-1046

WELD TIME:

500K Ω Pot, 3/4 turn	MDS-1053
Black Knob	MDS-1018
Knob Seal Nut	MDS-1046

SKIP TIME:

500K Ω Pot, 3/4 turn	MDS-1053
Black Knob	MDS-1018
Knob Seal Nut	MDS-1046

SPEED CONTROL:

10K Ω Pot, 3 turn	PCB-1026
Black Knob	MDS-1018
Shaft Seal Nut	MDS-1046

MODE:

Switch and Spacer	MDS-1115
Toggle Switch Boot	MDS-1047

MDS-1004 PROGRAMMABLE MODULE

The MDS-1004 PROGRAMMABLE MODULE provides stitch controls for welding or cutting with the Modular Drive System. All stitching parameters are set and displayed on a graphic screen. This allows each setting to be set exactly the same every time. See MDS-1004 Manual for detailed instructions.

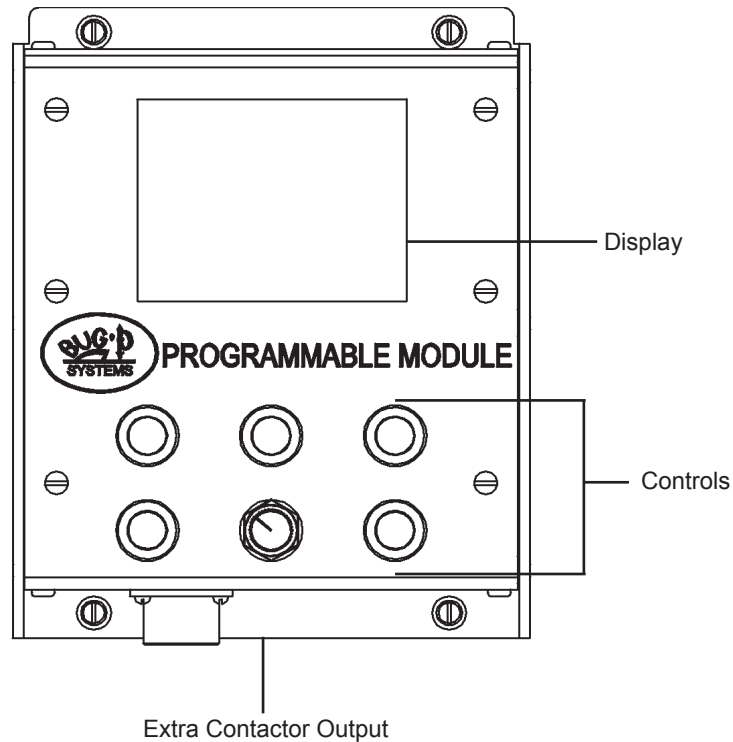

FEATURES

- Each stitch setting is displayed while being set. This allows each setting to be exactly set each time a job is set up.
- Closed loop encoder feedback is employed to ensure the traveled distances match the set distances.
- The module provides an extra contactor output. This output and the output on the Modular Drive can be disabled or enabled independently.
- The module will stop the machine or return it to start after a preset number of welds. This eliminates the need for external limit switches.
- This unit can return past the start location to allow for work piece changes. One button will start the whole welding procedure.
- Stitch welds stopped in mid-job can be restarted without interrupting the weld pattern.
- Puddle-buildup and Crater-fill timers are independent.

WEAVER CONTROL MODULES

MDS-1005 WEAVER CONTROL MODULE

The MDS-1005 Weaver Control Module provides weave welding control functions.

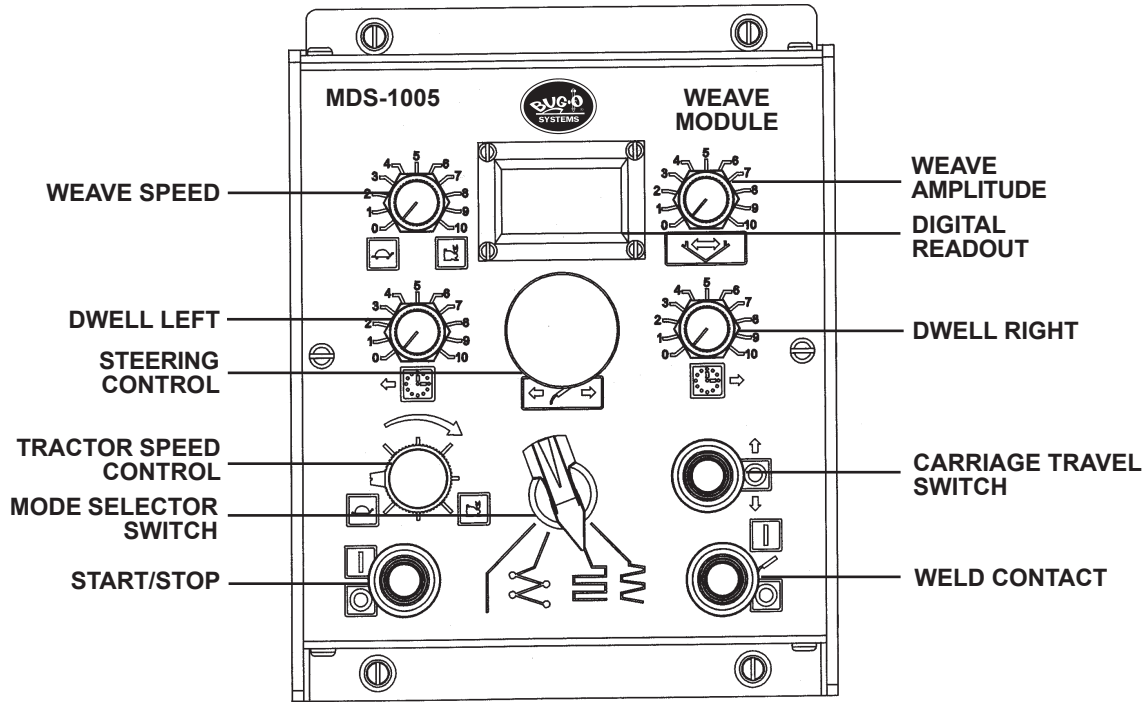

MDS-1005-DIAL WEAVER CONTROL MODULE

The MDS-1005 Dial Weaver Control Module provides weave welding control functions with 3 turn digital dial pots for the weave speed, weave amplitude, dwell left and right. The addition of the dial pots allows for precise and repeatable setting of all parameters. The dial pots also enable repeatable parameter settings from machine to machine. All dials vary from 0-300 which corresponds to the setting the parameter from 0 to its MAX value. For example, a 300 setting for weave amplitude corresponds to 2" of weave amplitude which is its max value. The DIGITAL READOUT provided for the tractor speed displays in either inches per minute or centimeters per minute directly.

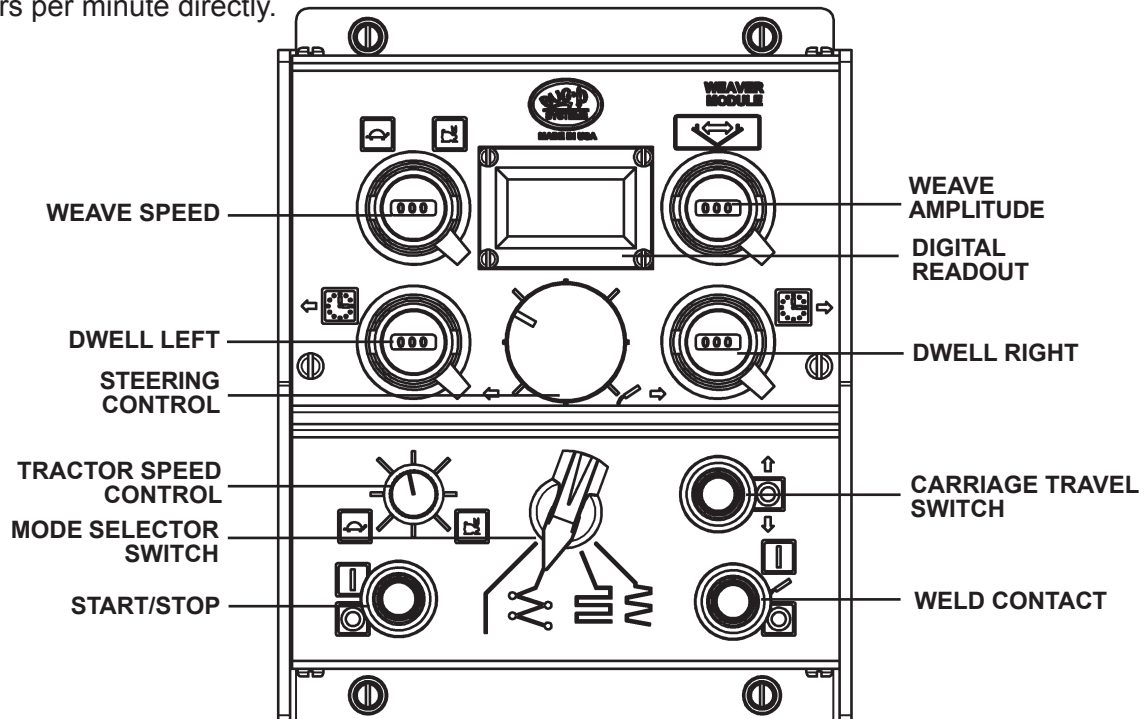

WEAVER CONTROL MODULES, CONT'D.

AMPLITUDE (WEAVE): Continuously adjustable up to a 2" (51 mm) maximum weaver stroke.

CARRIAGE TRAVEL SWITCH: Provides **FORWARD/STOP/REVERSE** direction control.

DIGITAL READOUT: Three tractor display modes exist.

- a) **PRESET SPEED** - Displayed when the **CARRIAGE TRAVEL SWITCH** is **OFF** or motion is halted by a motor overload condition.
- b) **CONTINUOUSLY MEASURED SPEED** - Displayed when the **MODE SELECTOR SWITCH** setting is **RUN** or **NO WEAVE**. (This will be the same as the Preset Speed.)
- c) **SAMPLED SPEED** - The tractor motion alternates between moving at the Preset Speed and stopping when the **MODE SELECTOR SWITCH** is set to **STEP** or **STOP ON DWELL**. This is referred to as "stepping" the tractor. To avoid having the display continuously fluctuate between the zero speed and the actual speed, the readout measures the travel speed near the end of each tractor step. This speed is then displayed until another sample is taken at the end of the next tractor step. This provides a stable display of the measured travel speed. (This will be the same as the Preset Speed.)

Factory settings of 120 Volt machines are set to in/min, 240 and 42 Volt machines are set cm/min.

LEFT AND RIGHT DWELL: The left and right dwell controls have a 0-3 second adjustment range.

MODE SELECTOR SWITCH: Four welding modes are available.

- 1) **RUN** - In this mode, power to the drive unit is always on and the machine travels continuously both during weave and dwell. Weave speed and dwell time both affect the weave pattern.
- 2) **STEP** - The unit travels only during dwell and stops during the weaver cross stroke. Changing weave speed does not effect the weld pattern-dwell time does.
- 3) **TRACTOR STOP ON DWELL** - The tractor travels during the weave stroke; the tractor and weaver stop during dwell.
- 4) **NO WEAVE** - In this mode oscillation is stopped. Only the tractor is powered. This mode is used for stringer passes.

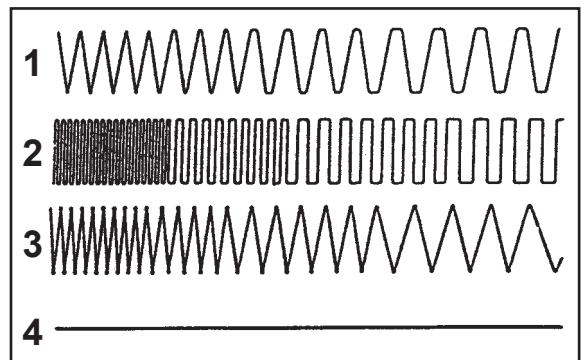

SPEED CONTROL (TRACTOR): Sets the tractor speed from 2-120 in/min (5.1-304.8 cm/min).

START/STOP: This enables/disables all tractor and weaver motion.

STEERING: The three-turn steering knob has a +/- 2" (51 mm) range.

WEAVE SPEED CONTROL: Sets the weave speed from 0-100 in/min (0-254 cm/min).

WELD CONTACT: Opens/closes a pair of independent 1 Amp contacts (pins A & B and C & D) at the weld contactor receptacle.

NOTE: A safety interlock will automatically open the weld contacts if the motor overload protection halts machine motion. Clear the overload by turning the carriage travel switch to off. Resetting the overload fault will not cause the contacts to automatically reclose. Use the weld contact switch to restart the welder after clearing the overload.

MDS-1005 / MDS-1005-DIAL WEAVER CONTROL MODULE REPLACEMENT PARTS

REPLACEMENT POTS AND SWITCHES		MDS-1005	MDS-1005-DIAL
WELD CONTACT:	Switch and Spacer	MDS-1114	
	Toggle Switch Boot	MDS-1047	
CARRIAGE TRAVEL SWITCH:	Switch and Spacer	MDS-1117	
	Toggle Switch Boot	MDS-1047	
DWELL RIGHT:	500K Ω Pot	MDS-1053	
	Black Knob	MDS-1018	
	Knob Seal Nut	MDS-1046	
	50K Ω Pot, 3 turn		MDS-1079
	Knob, Digital Dial		BUG-3297
	Dial Spacer		BUG-3302
AMPLITUDE:	10K Ω Pot	MDS-1052	MDS-1078 (3 turn)
	Black Knob	MDS-1018	
	Knob Seal Nut	MDS-1046	
	Knob, Digital Dial		BUG-3297
	Dial Spacer		BUG-3302
WEAVE SPEED:	10K Ω Pot	MDS-1052	MDS-1078 (3 turn)
	Black Knob	MDS-1018	
	Knob Seal Nut	MDS-1046	
	Knob, Digital Dial		BUG-3297
	Dial Spacer		BUG-3302
STEERING CONTROL:	10K Ω Pot, 3 turn	PCB-1027	
	Black Knob	BUG-5757	
	Knob Seal Nut	BUG-5759	
DWELL LEFT:	500K Ω Pot	MDS-1053	
	Black Knob	MDS-1018	
	Knob Seal Nut	MDS-1046	
	50K Ω Pot, 3 turn		MDS-1079
	Knob, Digital Dial		BUG-3297
	Dial Spacer		BUG-3302
TRACTOR SPEED CONTROL:	10K Ω Pot, 3 turn	PCB-1024	
	Knob	MDS-1044	
	Shaft Seal Nut	BUG-5759	
MODE SELECTOR SWITCH:	Switch and Spacer	MDS-1113	
	Black Pointer Knob	BUG-9694	
START/STOP:	Switch and Spacer	MDS-1115	
	Toggle Switch Boot	MDS-1047	

DIGITAL READOUT CALIBRATION

Internal Control Module adjustments enable the user to change between cm/min and in/min. The display can also be recalibrated, if required, to give an accurate speed readout.

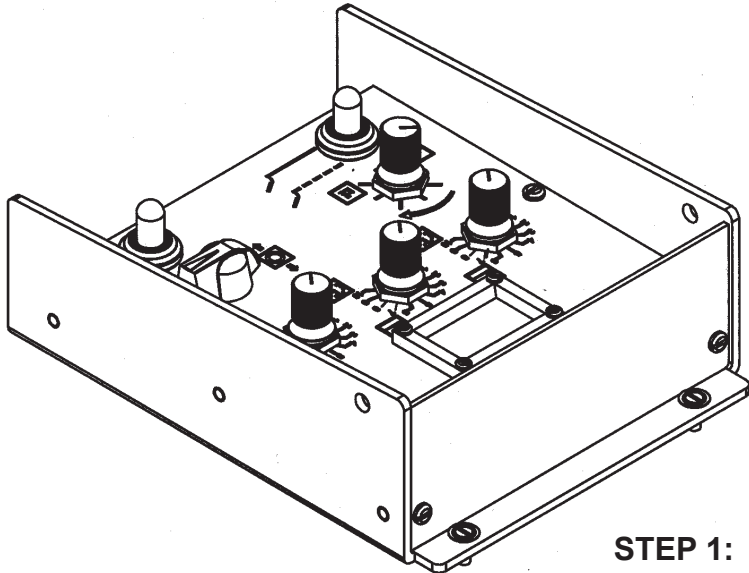

STEP 1: Remove endplate.

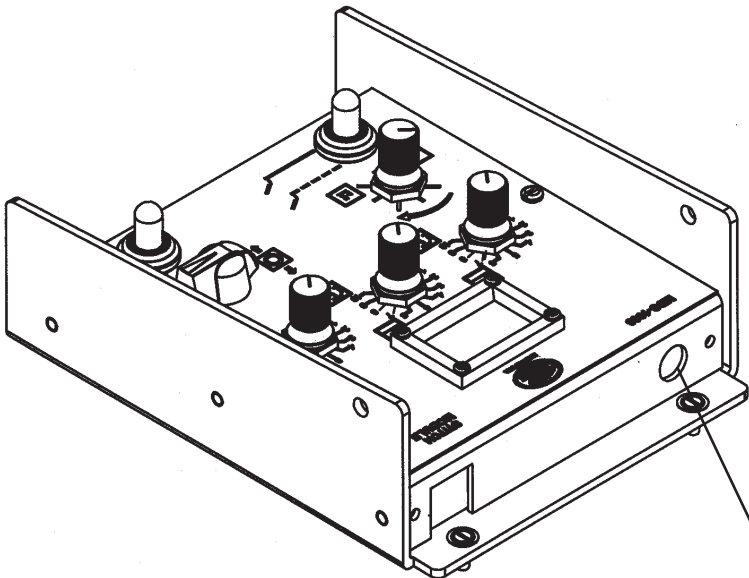

STEP 4: Calculate the speed of the machine by measuring how far it moves in a certain amount of time.

STEP 5: Set the speed display to the measured speed using a small slotted screwdriver.

STEP 6: Verify accuracy of speed display to actual speed and repeat steps 4 & 5 as needed.

STEP 7: Reinstall endplate.

STEP 2: Set Switch 1 & 2:

	SW 1	SW 2
in/min	Down	Down
cm/min	Up	Down

STEP 3: Apply power to the Modular Drive. Maximize the tractor speed using the Control Module front panel. Do not change this speed for the rest of the procedure.

WPD-1100 LINEAR WEAVER

INTRODUCTION

The **Linear Weaver** and **Weaver Control Module** add weave welding capability to the Modular Drive System. The Linear Weaver bolts onto the front of the carriage and the Weaver Control Module plugs into the top of the Master Drive Unit. The optional MDS-1060 Remote Control Cable can be used to remote the Control Module.

FEATURES

The Linear Weaver and Weaver Control Module incorporate the following standard features:

- High torque, low inertia motor for precise stops and starts.
- High speed Linear Weaver for weaving, with independent control of right and left dwell times.
- High motor gearing which prevents the crossarm from moving when the unit is turned off.
- Closed loop speed control for adjustable and repeatable control of critical welding or cutting parameters.
- Closed loop position control to prevent drift from the center weld position.
- Clutch, to enable rapid installation or replacement of the weaver cross arm.
- Gun mounting group with adjustable racking block for accurate positioning of the gun.
- Contactor ON/OFF switch.

The figure below shows how the Linear Weaver and Weaver Control Module connect to the carriage and Master Drive Unit.

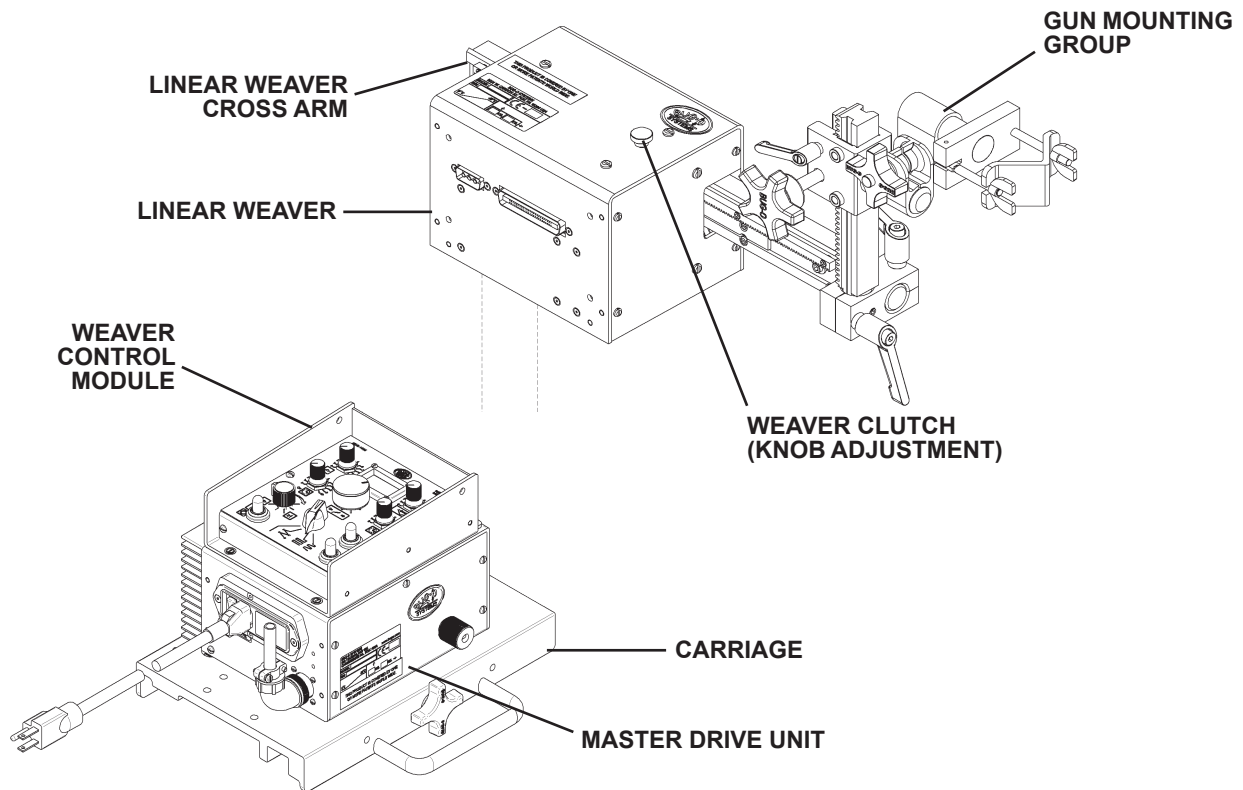

TECHNICAL DATA

WPD-1100 LINEAR WEAVER

Power Receives power from Master Drive.

Requirements: Uses 70 additional watts.

Dimensions: 7.25" L x 5.50" W x 5.37" H (184 x 140 x 137 mm)

Net Weight: 13.5 lbs (6.0 kg)

Shipping Weight: 16.5 lbs (7.5 kg)

Speed: 2-110 in/min (51-2794 mm/min)

Cycles:
2.5 cycles per second at 1/8" (3mm) stroke
1.6 cycles per second at 1/4" (6mm) stroke
1.0 cycles per second at 1/2" (12mm) stroke
0.7 cycles per second at 1.0" (25mm) stroke
(at maximum speed and 0 dwell)

Load Capacity: 10 lbs (4.5 kg)

DIMENSIONS

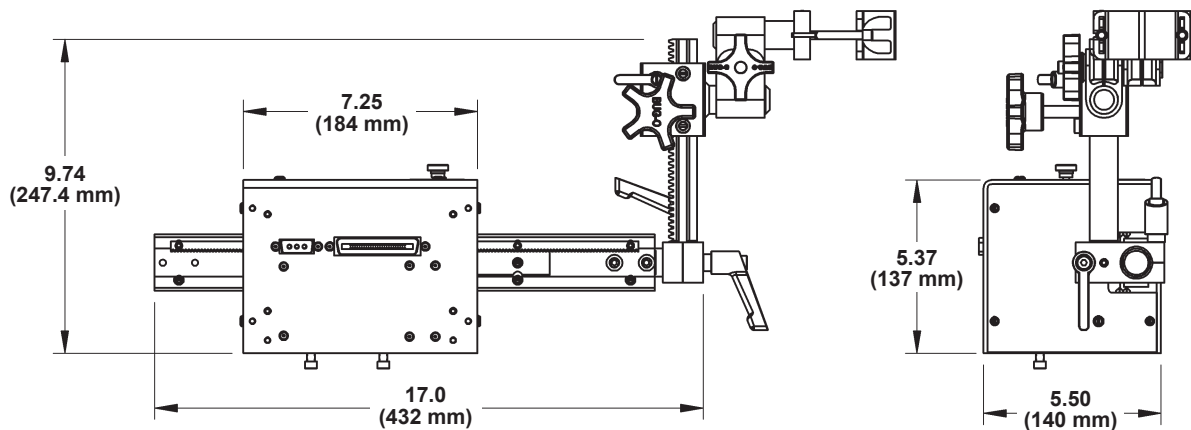

LINEAR WEAVER SETUP

1) WEAVER CONTROL MODULE AND LINEAR WEAVER INSTALLATION

The Weaver Control Module plugs into the top of the Master Drive Unit. Use a flat head screw driver to firmly secure the four corners of the module.

Place the Linear Weaver on a flat surface, connector side up. Remove connector cover plate from MPD-1000. Loosen, but do not remove, the bolts that hold the Master Drive Module to the carriage. Plug the Master Drive Module into the Linear Weaver. The connectors should fit together easily and do not need forced. Attach the Linear Weaver to the carriage using the two weaver mounting bolts. **DO NOT SUBSTITUTE LONGER BOLTS.** Retighten the bolts that hold the Master Drive Unit to the carriage.

2) CROSSARM WHEEL ADJUSTMENT AND ALIGNMENT

Always check the crossarm wheel adjustment before using the machine. The wheels are too loose and need adjustment if the crossarm can move up and down. Normal gear backlash will permit crossarm side to side movement of approximately 0.02" (0.5 mm).

If the wheels need adjustment, remove the left and right weaver end covers. The two top wheels are adjustable. Loosen the hex bolt (A) until the adjustable bushing (B) can be rotated. Correct the wheel alignment by rotating adjustable bushing (B).

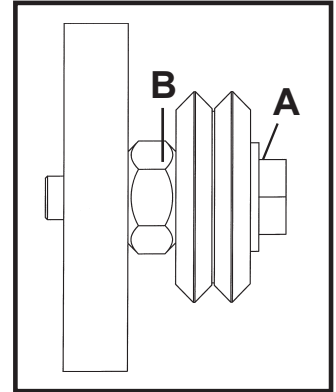

Check for proper alignment by using a finger to keep one of the wheels from rotating while manually moving the crossarm. The wheels are adjusted too tight if firm finger pressure is not enough to prevent wheel rotation. Once aligned, hold the adjustment bushing (B) still while tightening the hex bolt (A). Recheck alignment.

3) REALIGNING THE CROSSARM

(includes crossarm INSTALLATION and REMOVAL)

Rotate the clutch knob (C) fully counterclockwise. This disengages the drive pinion from the rack. Remove the two socket head screws from the crossarm (D). The crossarm may be removed from or installed into the Linear Weaver at this time.

Turn on the AC power. Rotate the four-turn steering control knob and the weave speed knob on the Weaver Control Module fully clockwise. Turn the start/stop switch to START. Set the mode selector switch to NO WEAVE. Align the crossarm (D) so that 1 7/8" (48 mm) of the crossarm protrudes from the left side of the Linear Weaver. To insure proper gear mesh, gently rock the crossarm back and forth about 1/16" (2 mm) while engaging the pinion using the clutch knob (C).

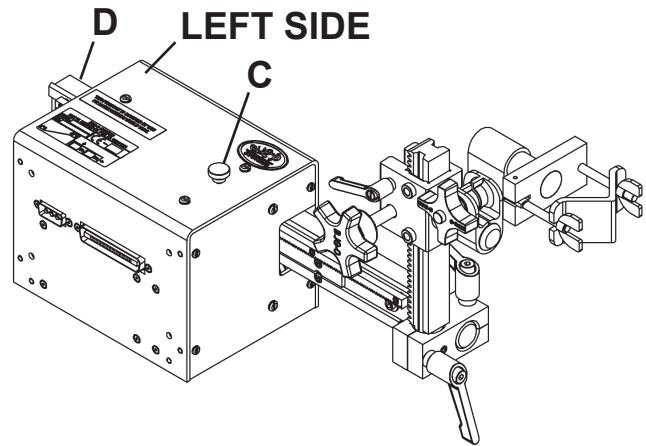

CAUTION: IMPROPER GEAR MESH MAY CAUSE PINION, RACK, OR LINEAR WEAVER DAMAGE.

Set the weave amplitude to maximum. Use the steering knob on the control module to move the crossarm to both the extreme left and the extreme right. Perform measurements to determine if The crossarm is installed too far left or too far right. Repeat the crossarm realigning procedure changing the 1 7/8" (48 mm) dimension as required. Reinstall the two crossarm screws.

LINEAR WEAVER SETUP, CONT'D.

4) REMOTE CONTACTOR WIRING

Connect the remote weld contactor on the Master Drive to the welding source as shown below.

Pins A and Bconnection for Output #1
Pins C and Dconnection for Output #2

5) GUN AND SETUP

For welding, insert the welding gun into the all-position clamp on the rack. Adjust the clamp, the clamp block and the rack to position the gun for welding. Connect the weld contactor connector to the rear of the Master Drive Unit. Route the welding cable and weld contactor wires through the cable anchor clamp. Turn on the AC power. Use the steering knob on the control module to move the crossarm to both the extreme left and then the extreme right. Turn on the oscillator, at the same time, with the controls set to maximum weave width. Readjust the crossarm or the gun if the racking fixture hits the case during operation.

6) MACHINE OPERATION

Turn the main power ON at the power entry box. Set the following parameters using the MDS-1005 Control Module (Ref. pg. 18 for illustration):

Weld Mode Selector Switch

Tractor Speed Control

Steering Control

Weave Amplitude

Weave Speed

Left and Right Dwells

The Start/Stop control will turn on the weaver. To start welding, push the weld contactor switch "ON" (momentarily) which will turn on the wire feeder/weld current. Use the carriage travel switch to select a forward or reverse carriage travel direction.

CAUTION: The Speed Control Card in the Linear Weaver is **NOT** interchangeable with the speed card in the Master Drive or Pendulum Weaver.

WPD-1100 LINEAR WEAVER / EXPLODED VIEW

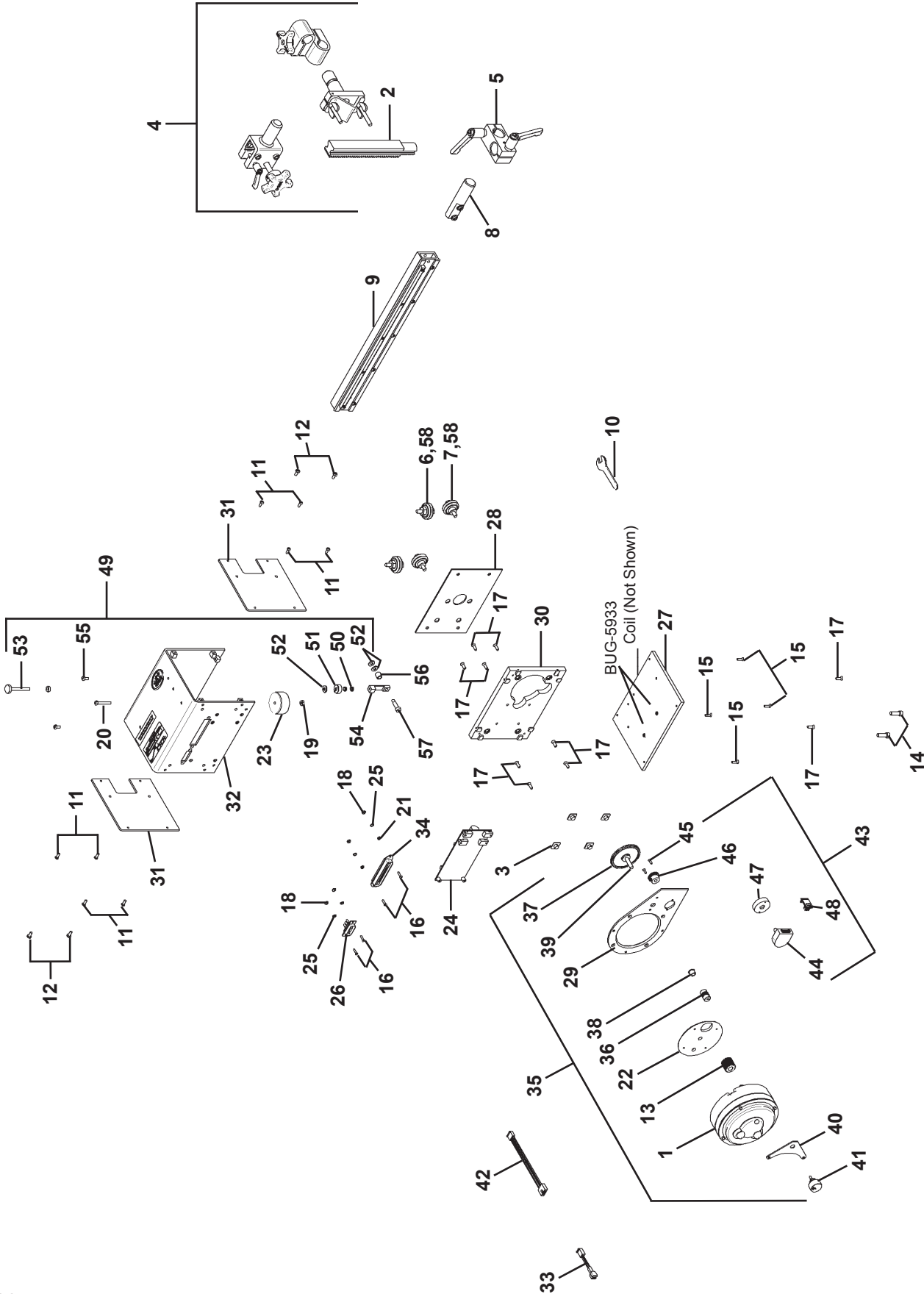

WPD-1100 LINEAR WEAVER / PARTS LIST

<u>ITEM</u>	<u>QTY</u>	<u>PART NO.</u>	<u>DESCRIPTION</u>
1	1	MOT-0002	Gear Motor (80:1) 24V
2	1	BUG-1853	Machine Rack 7 1/2" (191 mm) Lg
3	4	BUG-2593	Glide Flat
4	1	BUG-5455	Gun Mounting Group
5	1	BUG-5462	Right Angle Clamp
6	2	CWO-4021	Adj Leg & Wheel Assembly
7	2	CWO-4020	Fixed Leg & Wheel Assembly
8	1	WPD-1178	Post w/Fasteners
9	1	WPD-1150	Cross Arm
10	1	BUG-9447	Wrench
11	8	FAS-0114	Pan Hd Scr 6-32 x 3/8 Lg
12	6	FAS-0124	Pan Hd Scr 8-32 x 3/8 Lg
13	1	WPD-1028	Pinion, 3/4 PD, 24 Teeth
14	2	FAS-0557	Soc Hd Cap Scr 1/4-20 x 3/4 Lg
15	4	FAS-0815	Flt Hd Slit Scr 6-32 x 1/2 Lg
16	10	FAS-0905	Flt Hd Soc Scr 4-40 x 1/2 Lg
17	10	FAS-0925	Flt Hd Soc Scr 8-32 x 1/2 Lg
18	4	FAS-1305	Hex Nut 4-40
19	1	FAS-1325	Hex Nut 8-32 Nylon
20	1	FAS-2121	Pan Hd Scr 8-32 x 1 1/4 Lg
21	2	MDS-1034	Spacer Washer .125 ID x .255 OD x .06 Thk
22	1	MPD-1013	Clutch Plate
23	1	MPD-1042	Inductor, Potted w/Connectors
24	1	PCB-1014	Precision Speed Board
25	4	WAS-0201	# 4 Internal Star Lockwasher
26	1	WPD-1001	Ground Harness
27	1	WPD-1002	Weaver Base Plate Assembly**
28	1	WPD-1103	Dust Plate
29	1	WPD-1004	Motor Mount Plate
30	1	WPD-1106	Oscillator Mount Plate
31	2	WPD-1110	Side Panel
32	1	WPD-1020	Cover Panel
33	1	WPD-1022	Wiring Harness-Speed Board to Motor
34	1	WPD-1023	Connector, 50-Pin, M
35	1	WPD-1025	Pot/Gear Assembly (Includes items 36 thru 41)
36	1	BUG-5235	Flexible Coupling
37	1	BUG-5596	Gear, 72 Teeth
38	1	SFX-1218	Flange Bearing
39	1	WPD-1026	Shaft .250 Dia x .675 Lg
40	1	WPD-1027	Pot Mounting Bracket
41	1	WPD-1037	Potentiometer w/Wiring
42	1	WPD-1029	Encoder/Speed Board Wiring Harness
43	1	WPD-1030	Pinion/Encoder Assembly (Includes items 44 thru 48)
44	1	WPD-1049	Encoder
45	2	FAS-0904	Flt Hd Soc Scr 4-40 x 3/8 Lg
46	1	WPD-1031	Pinion Assembly
47	1	WPD-1033	Encoder Spacer
48	1	WPD-1034	Encoder Card
49	1	WPD-1035	Clutch Assembly (Includes items 50 thru 55)
50	2	FAS-1340	Hex Nut 10-32
51	1	SFX-1224	Sleeve
52	3	WAS-0230-55	#10 Washer
53	1	WPD-1038	Thumb Screw Knob with 1.75" Stud
54	1	WPD-1166	Clutch Linkage
55	1	WPD-1043	Black Nylon Spacer .118" Thick
56	1	STOF-0804	Spacer, 3/8"OD, 1/4"ID, 3/8" Long, Alum
57	1	WPD-1167	10-32 Shoulder Bolt, 3/8" Long
58	4	WAS-0240	1/4 Flat Washer

** (Includes (2) BUG-5933 Helicoils 1/4 x 20 x 1/4 Lg - Not Shown)

WPD-2100 PENDULUM WEAVER II

INTRODUCTION

The **Pendulum Weaver** and **Weaver Control Module** add a pendulum-type weaving motion to the Modular Drive System. The Pendulum Weaver is particularly useful for weaving fillet welds in a corner joint. The weaver motor box is mounted to the front of the carriage using standard racks and rackholders.

FEATURES

- High torque, low inertia motor for precise starts and stops.
- Heavy duty planetary gear box with powerful output shaft for rotating welding gun and attachments for the gun.
- High speed pendulum motion with independent control of right and left dwell times.
- High motor gearing ratio, that prevents the welding gun from moving by backdriving the gear train when power is off.
- Closed loop speed control for adjustable and repeatable control of critical welding or cutting parameters.
- Closed loop position control to prevent drift from the center position.
- Gun mounting group with adjustable racking block for accurate positioning of the gun.
- Weld Contactor ON/OFF switch.

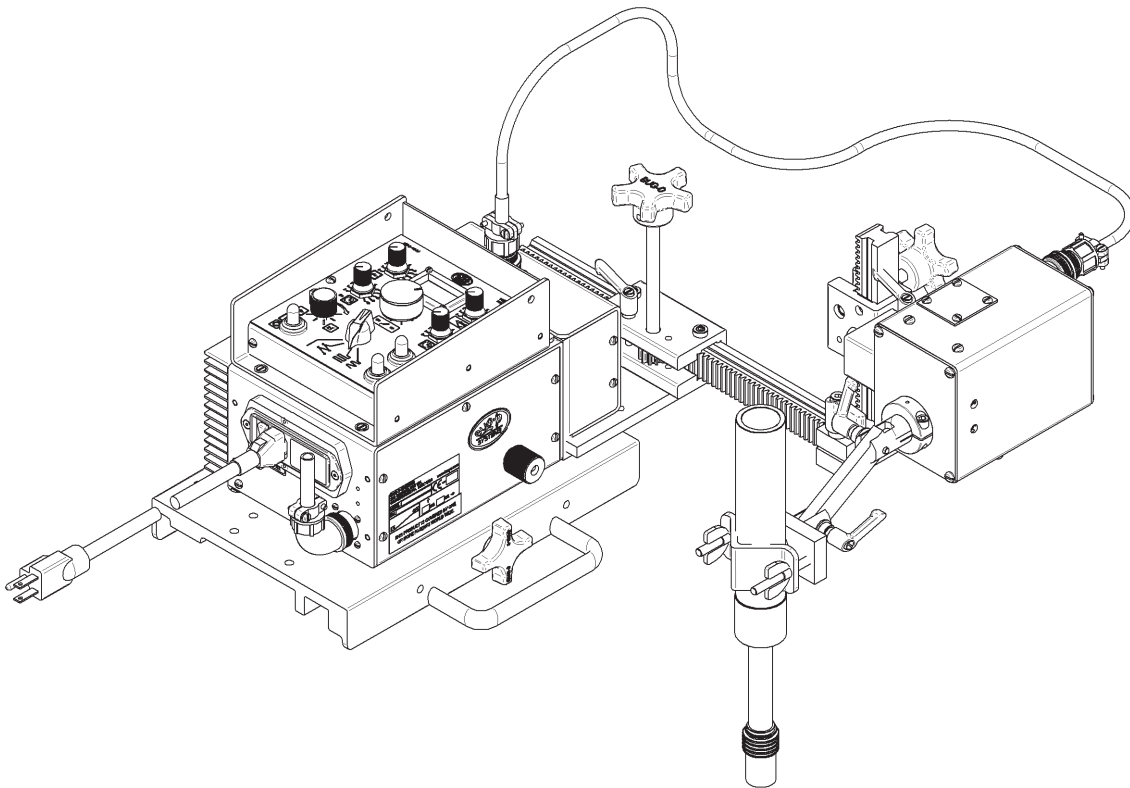

PENDULUM WEAVER II SETUP

INSTALLATION

The Weaver Control Module plugs into the Master Drive Unit. Use a flat blade screwdriver to firmly secure the four corners of the module.

Remove connector cover plate from MPD-1000. Plug the Pendulum Weaver Electronics box into the front end of the Master Drive Unit. Secure the box to the drive unit by using the four captive screws on the electronics box.

Bolt the mounting plate onto the front of the carriage, below the electronics box, and bolt the rackholder onto the mounting plate. Insert the 14" (355 mm) rack through it.

Several different arrangements can be used to mount the gearbox on the rack and to position the welding gun. One recommended assembly method is shown below: bolt the racks, gearbox, and clamps together as shown in the diagram.

Finally connect the gearbox to the electronics box using the cable supplied, with 6-pin connectors on each end.

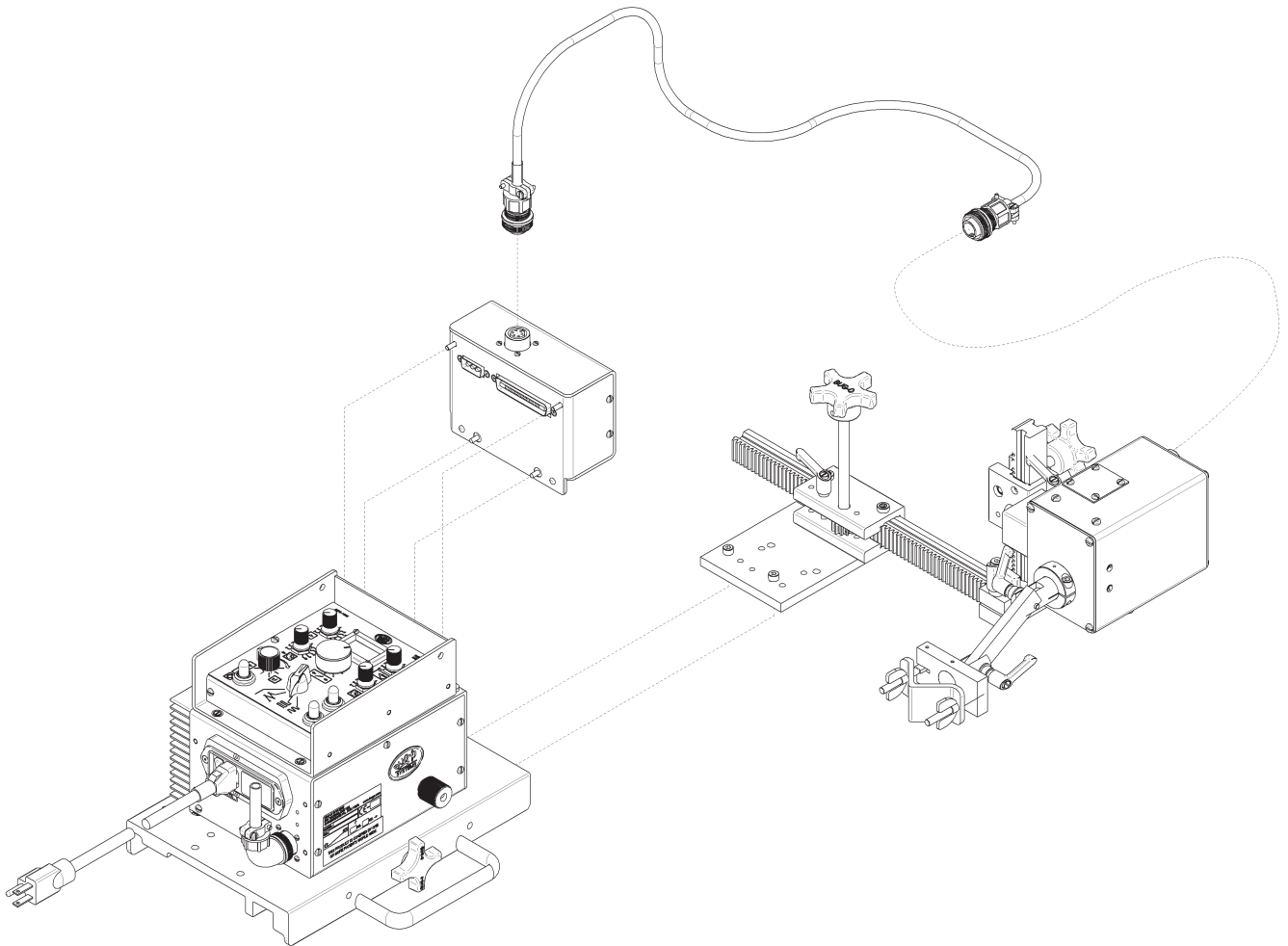

SETUP AND ALIGNMENT

Attach the rail parallel to the weld joint, with magnet bars or vacuum cups. Position the drive carriage on the rail - see Modular Drive instructions if necessary.

Insert the welding gun into the clamp on the pendulum weaver. Adjust the racks and clamps to align the welding gun tip with the weld joint, and tighten firmly in place.

IMPORTANT!

When the welding gun is clamped in place with the nozzle pointing into the weld groove, the centerline of the wire must pass through the axis of the gearbox output shaft, as shown in Figure A, which is a view looking along the shaft. Figure B shows the side view of the same.

For a fillet weld, the nozzle will be at a 45° angle as shown in Figure C, and will swing equally in both directions.

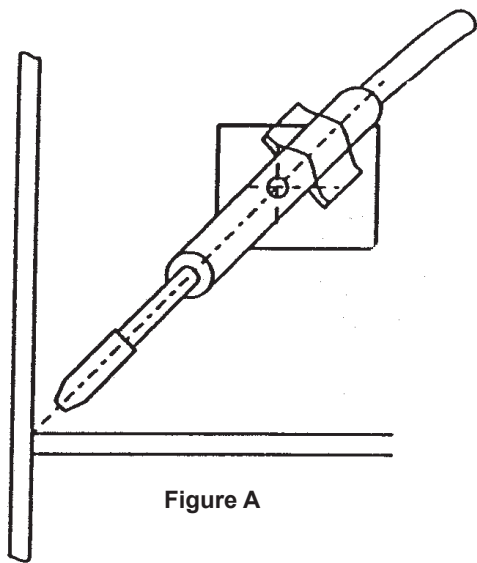

Figure A

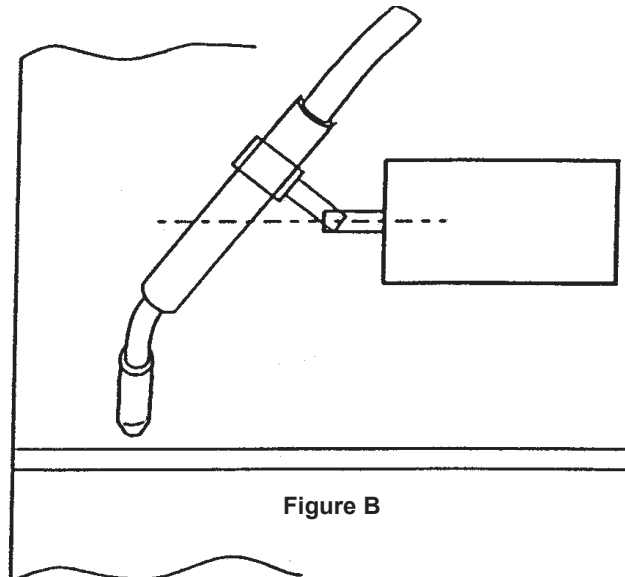

Figure B

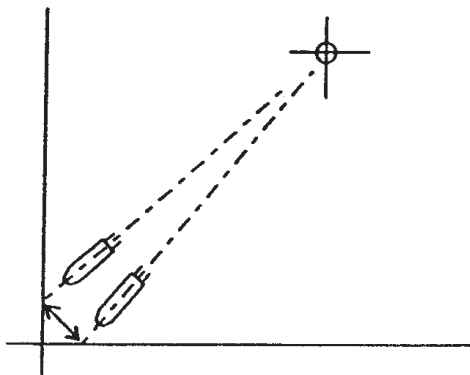

Figure C

CAUTION: The Speed Control Card in the Pendulum Weaver is NOT interchangeable with the speed card in the Master Drive or Linear Weaver.

TECHNICAL DATA

WPD-2100 PENDULUM WEAVER II

Power Requirements: Uses 70 watts, received from Master Drive Unit.

Dimensions:
Electronics Box: 6.0"W x 4.38"H x 2.38"L (152 x 111 x 60.3 mm)

Gearbox: 3.31"W x 4.10"H x 5.66"L (84 x 104 x 144 mm)

Net Weight: 12.88 lbs (5.84 kg)

Speed:* 0 - 200 ipm (0-5080 mm/m)

Cycles:*
 3.7 cycles per second at 1/8" (3 mm) stroke
 3.0 cycles per second at 1/4" (6 mm) stroke
 2.0 cycles per second at 1/2" (12 mm) stroke
 1.3 cycles per second at 1.0" (25 mm) stroke
 (at maximum speed and 0 dwell)

Stroke:* 2" (51 mm)

Steering:* 4" (101 mm) to 2" (51 mm), each side of center

Dwell Time: 0 - 3 seconds, left and right

Load Capacity: 10 lbs (4.5 kg)

*all measured at a 6" (152mm) radius

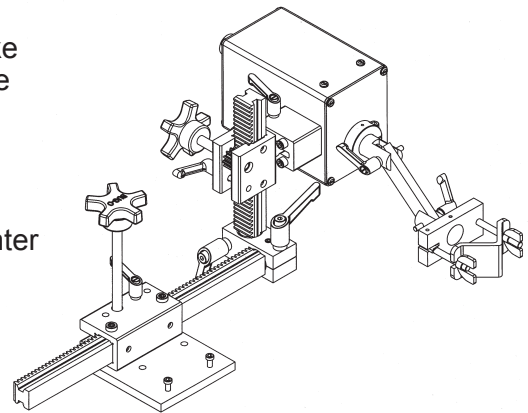

DIMENSIONS

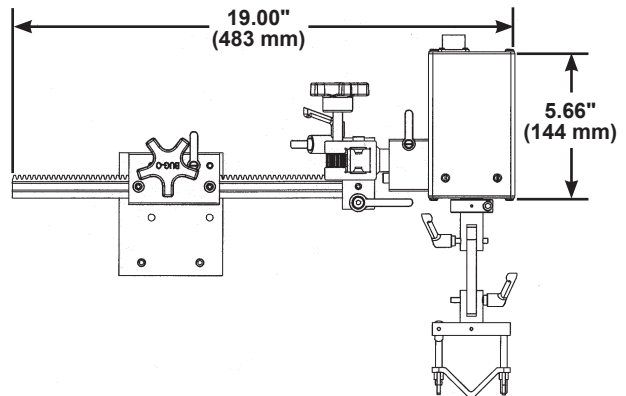
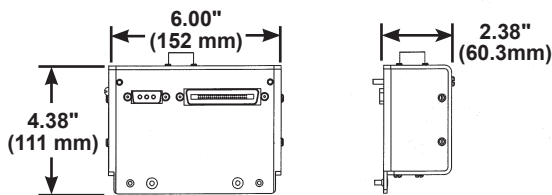

Electronics Box

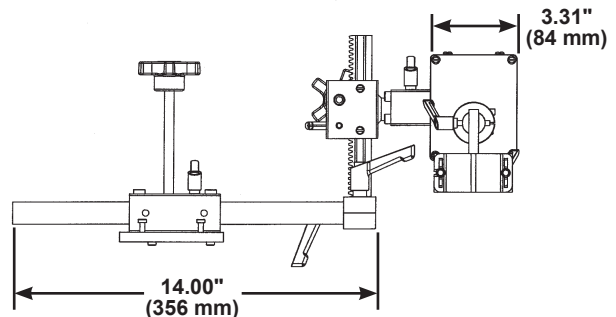
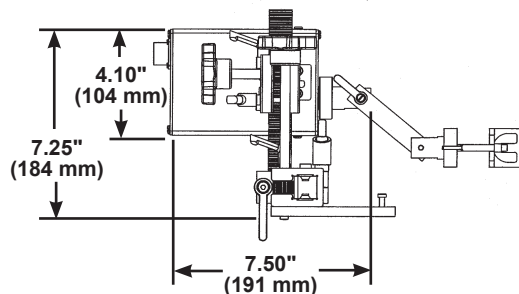

WPD-2100 PENDULUM WEAVER II / EXPLODED VIEW / PARTS LIST

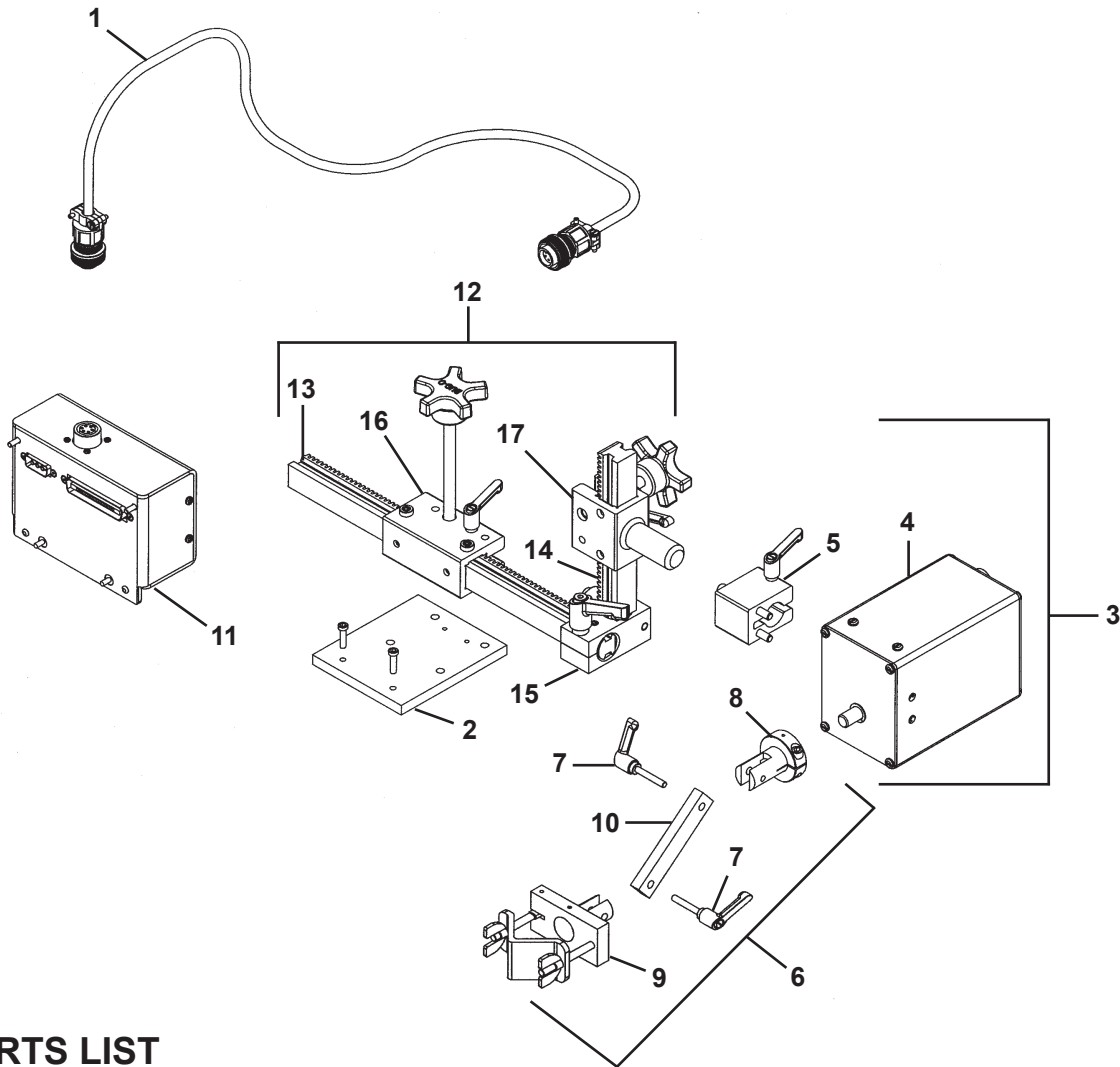

PARTS LIST

<u>ITEM</u>	<u>QTY</u>	<u>PART NO.</u>	<u>DESCRIPTION</u>
1	1	MUG-1634-3	Power Cable, 3' (914 mm)
2	1	MDS-1029	Mounting Plate w/Screws
3	1	WPD-2110	Pendulum Gear Box (Includes items 4, 5, 6)
4	1	WPD-2115	Gear Box
5	1	WPD-2041	Clamp Block
6	1	WPD-2050	Gun Mounting Group (Includes items 7 thru 10)
7	2	BUG-2234	Adjustable Clamping Lever
8	1	WPD-2044	Shaft Adaptor w/Collar
9	1	WPD-2052	Gun Clamp
10	1	WPD-2053	Link
11	1	WPD-2120	Pendulum Weaver Electronics Box
12	1	WPD-2040	Pendulum Mounting Group (Includes items 13 thru 17)
13	1	BUG-1796	Machined Rack 14" (355 mm)
14	1	BUG-1853	Machined Rack 7-1/2" (191 mm)
15	1	BUG-5462	Right Angle Clamp
16	1	MDS-1031	3.5" (89 mm) Rackholder w/Long Handle
17	1	UNI-1036	Rackrider w/Post

WPD-2120 PENDULUM WEAVER II / ELECTRONICS / EXPLODED VIEW

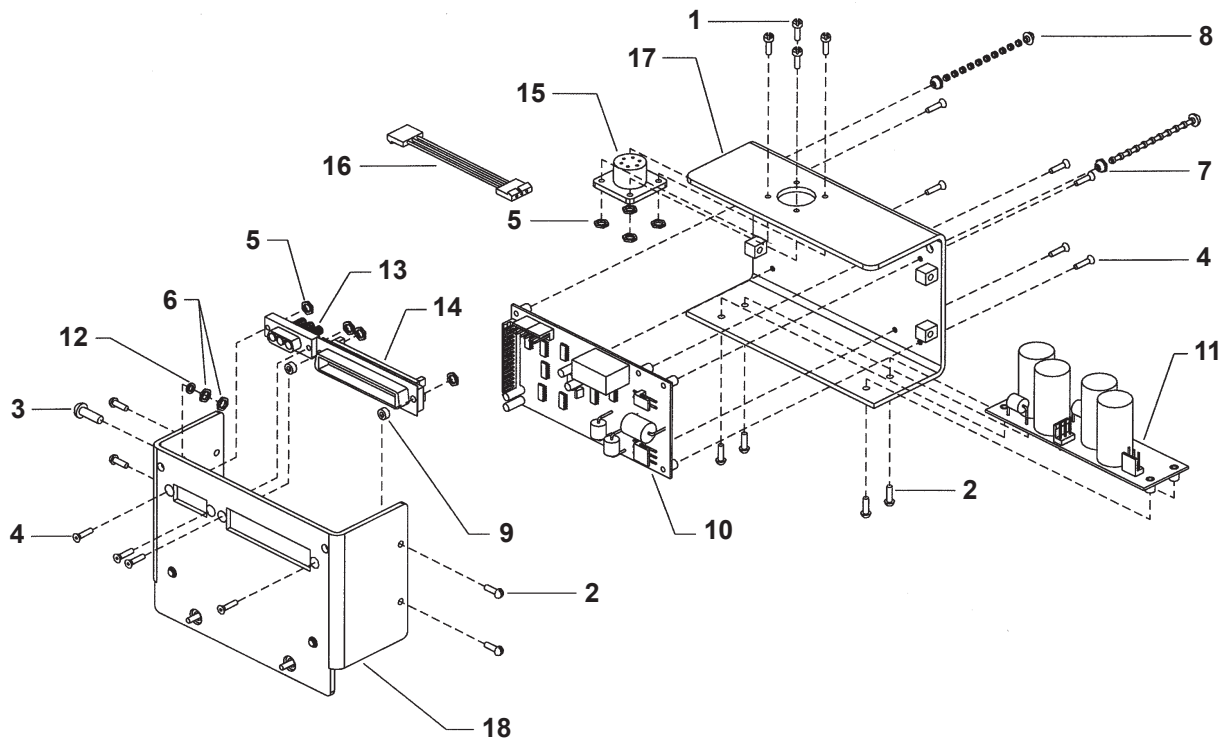

PARTS LIST

<u>ITEM</u>	<u>QTY</u>	<u>PART NO.</u>	<u>DESCRIPTION</u>
1	4	FAS-0104	Pan Hd Scr 4-40 x 3/8 Lg
2	8	FAS-0114	Pan Hd Scr 6-32 x 3/8 Lg
3	1	FAS-0225	Rnd Hd Scr 8-32 x 1/2 Lg
4	10	FAS-0905	Flt Hd Soc Scr 4-40 x 1/2 Lg
5	8	FAS-1305	Hex Nut 4-40
6	2	FAS-1320	Hex Nut 8-32
7	2	FAS-1322	Hex Nut 8-32 Nylock
8	2	FAS-2127	Pan Hd Scr 8-32 x 2 3/4 Lg
9	2	MDS-1034	Spacer Washer .125 ID x .255 OD x .06 Thick
10	1	PCB-1009	Speed Board for Pendulum Weaver
11	1	PCB-1021	Capacitor Card
12	1	WAS-0221	#8 Internal Star Lockwasher
13	1	WPD-1001	Ground Harness
14	1	WPD-1023	Connector, 50-Pin, Male
15	1	WPD-2005	Wiring Harness
16	1	WPD-2006	Wiring Harness-Capacitor Bd to Speed Bd
17	1	WPD-2011	Front Panel
18	1	WPD-2012	Rear Panel

WPD-2115 PENDULUM GEAR BOX / EXPLODED VIEW / PARTS LIST

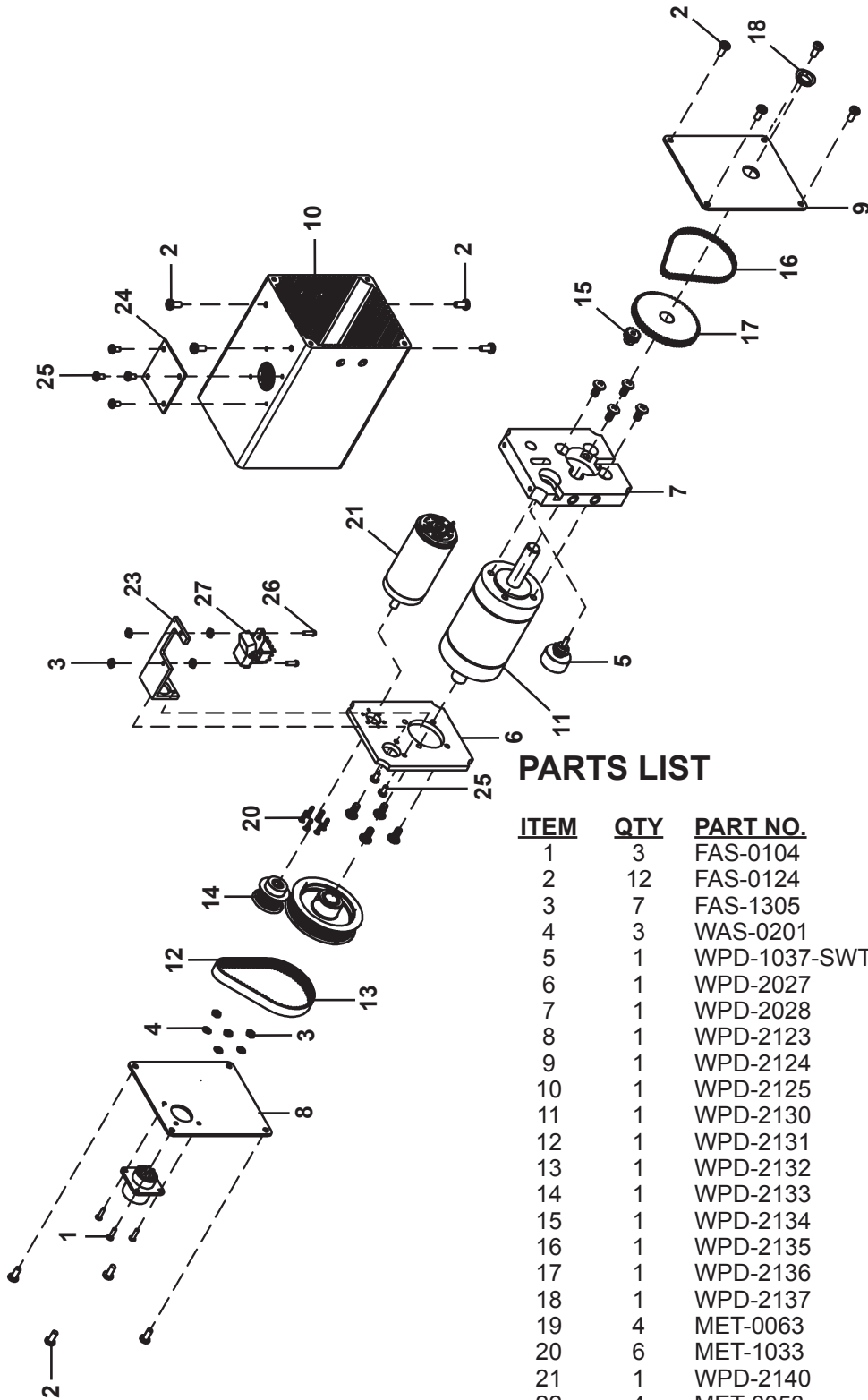

PARTS LIST

ITEM	QTY	PART NO.	DESCRIPTION
1	3	FAS-0104	Pan Hd Scr 4-40 x 3/8"
2	12	FAS-0124	Pan Hd Scr 8-32 x 3/8"
3	7	FAS-1305	Hex Nut 4-40
4	3	WAS-0201	#4 Internal Lock Washer
5	1	WPD-1037-SWT	Pot w/ Switch & Wiring
6	1	WPD-2027	Motor Mounting Plate
7	1	WPD-2028	Pot Mounting Plate
8	1	WPD-2123	Rear End Plate
9	1	WPD-2124	Output End Plate
10	1	WPD-2125	Enclosure Extrusion
11	1	WPD-2130	120:1 Gearbox
12	1	WPD-2131	Timing Belt 3mm
13	1	WPD-2132	Timing Pulley 60 Grooves
14	1	WPD-2133	Timing Pulley 22 Grooves
15	1	WPD-2134	Pulley 14 Teeth
16	1	WPD-2135	Drive Belt 32 Pitch
17	1	WPD-2136	Pulley 72 Teeth
18	1	WPD-2137	Flanged Clip Bearing
19	4	MET-0063	M5-0.8 x 10 Pan Hd Philips
20	6	MET-1033	M2.5-0.45 x 10 Flat Hd Philips
21	1	WPD-2140	Motor w/ Wires
22	4	MET-0053	M4-0.7 x 10 Pan Hd Philips
23	1	WPD-2106	Switch Bracket
24	1	WPD-2105	Switch Cover
25	6	FAS-0112	Pan Hd Scr 6-32 x 1/4" Black
26	2	FAS-0204	Rnd Hd Scr 4-40 x 3/8"
27	1	SWT-1126	Rocker Switch
*	1	BUG-9692	Tie Wrap
*	1	WPD-2141	Wiring Harness

*Not Shown

WPD-1100 LINEAR WEAVER, WPD-2100 PENDULUM WEAVER WIRING DIAGRAM***

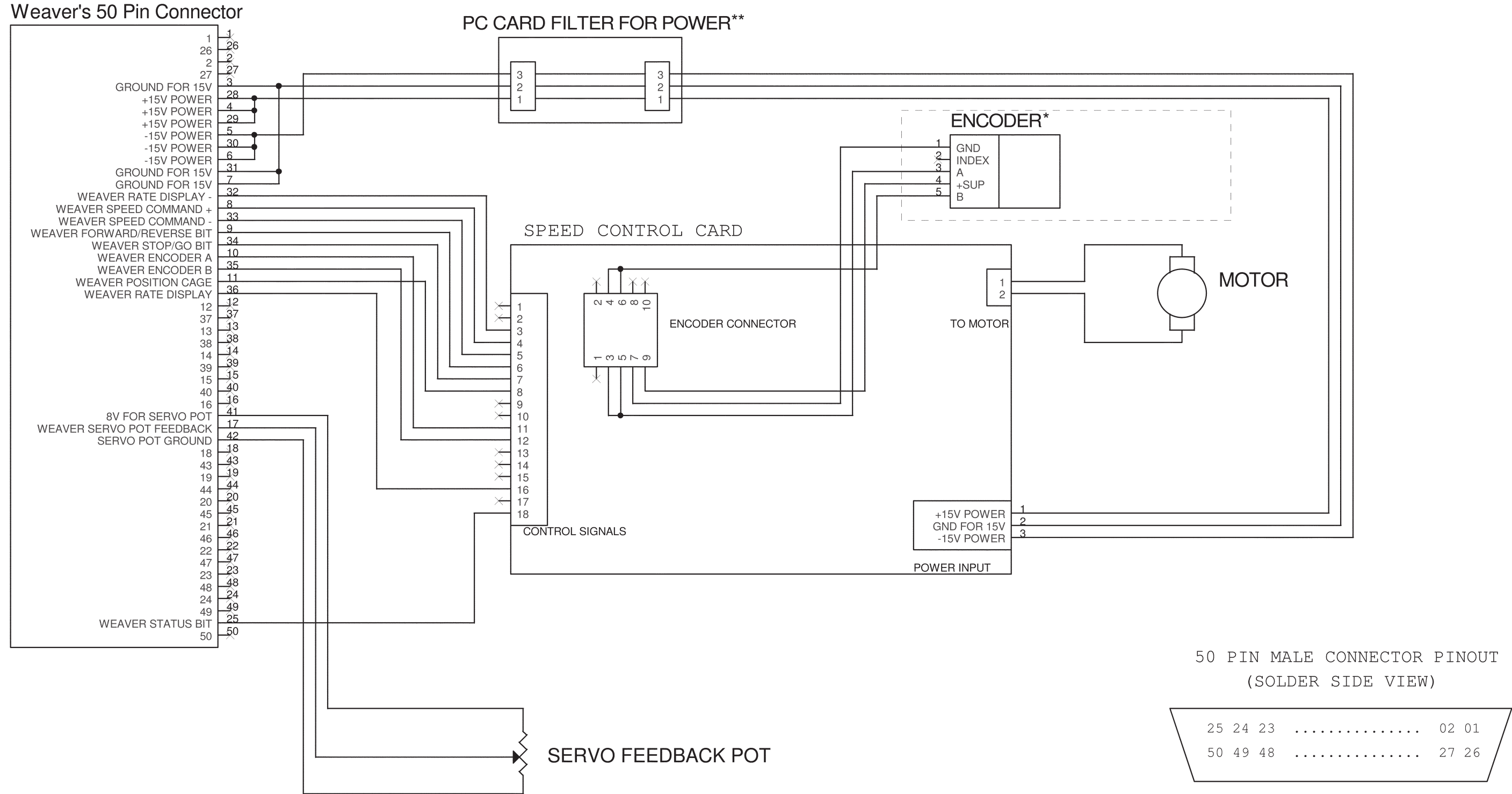

Notes:

- * The encoder section outlined is for the WPD-1000 Linear Weaver only.
- ** The PC Card to filter power is only used in WPD-2000 Series Pendulum Weavers.
- ***Wiring diagram will also work for older WPD-1000 and WPD-2000 Weavers.

CARRIAGES

The MPD-1065 Releasable 12" (305 mm) and FMD-1105 12" (305 mm) Hi Flex Carriages can be placed anywhere on the track by using the knob located on the side of the carriage, which engages or disengages the wheels from the rail. The MPD-1055 18" (457 mm) Carriage provides an extended deck for mounting accessories, wire feeder, etc. The pinion from the drive unit engages the rack on the rail, providing positive drive in all positions. On each carriage, one set of wheels is adjustable to allow for smooth, accurate travel. All wheels contain permanently lubricated, sealed bearings and their steel components are plated to resist corrosion.

FOR HI-FLEX RAIL

FMD-1105 12" HI FLEX CARRIAGE 100 lb (45 kg) Carrying Capacity

The Hi-Flex Carriage can be placed anywhere along the track using the quick release knob on the side of the carriage to engage/disengage the wheels from the track. Use with BUG-O Hi-Flex Rails.

FMD-1105 HI-FLEX CARRIAGE / PARTS LIST / EXPLODED VIEW

ITEM	QTY	PART NO.	DESCRIPTION
1	4	BUG-2841	Washer 5/8" O.D. X 5/16" I.D. Teflon
2	2	FAS-0659	Soc Hd Shr 5/16-18 X 1"
3	2	FMD-1093	Standoff .875 Dia. .688 Lg.
4	1	MPD-1035	Handle W / Cable Anchor
5	4	FAS-0956	Screw, Flat Hd Cap 5/16-24 x 5/8
6	1	FMD-1022	Carriage For Flex Rail
*A	1	FMD-1068	Fixed Wheel Mounting Block
*B	1	FMD-1069	Adj. Wheel Mounting Block
*C	1	FMD-1081	Bearing Block
*D	8	FAS-0386	Screw, Hex Hd Cap 5/16-24 x 5/8
*E	8	BUG-2012	Bearing
*F	8	CON-1029	Washer, 5/16 x 0.015
*G	2	FMD-1083	Dowel Pin, 1/2 x 2"
*H	1	FMD-1071	Threaded Shaft
*J	2	BUG-2848	Cam Spacer
*K	1	FMD-1072	Knob
*L	1	FMD-1026	Carriage Base

*Part of Item 6 (FMD-1022)

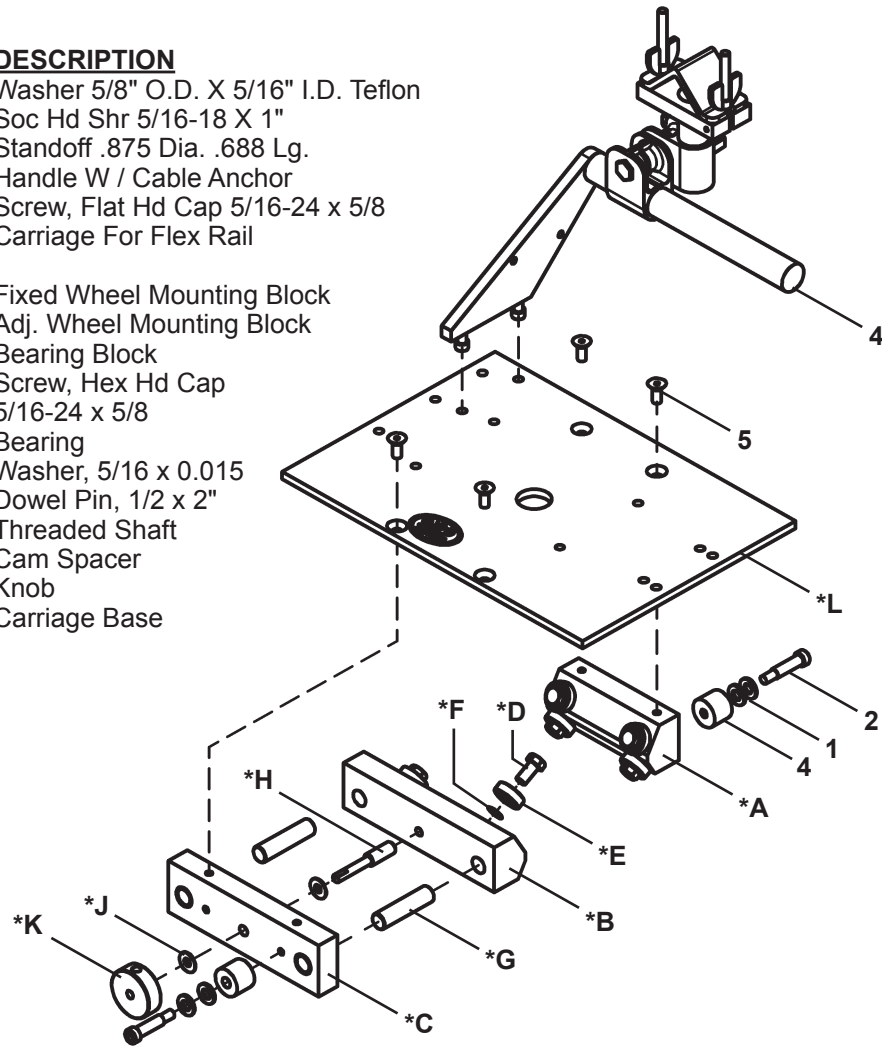

FOR ALUMINIUM RIGID RAIL AND SEMI-FLEX RAIL

MPD-1065 RELEASABLE CARRIAGE 12" (305 mm) 100 lb (45 kg) Carrying Capacity

PARTS LIST / EXPLODED VIEW

ITEM	QTY	PART NO.	DESCRIPTION
1	2	BUG-1984	External Adj Leg & Wheel Assembly
2	2	FAS-0545	Soc Hd Cap Scr 10-32 x 1/2 Lg
3	2	MPD-1045	Fixed Leg & Wheel Assembly
4	1	MPD-1049	Handle, Black
5	1	MPD-1059	Knob Screw (Included w/carriage)
6	1	MPD-1066	Carriage

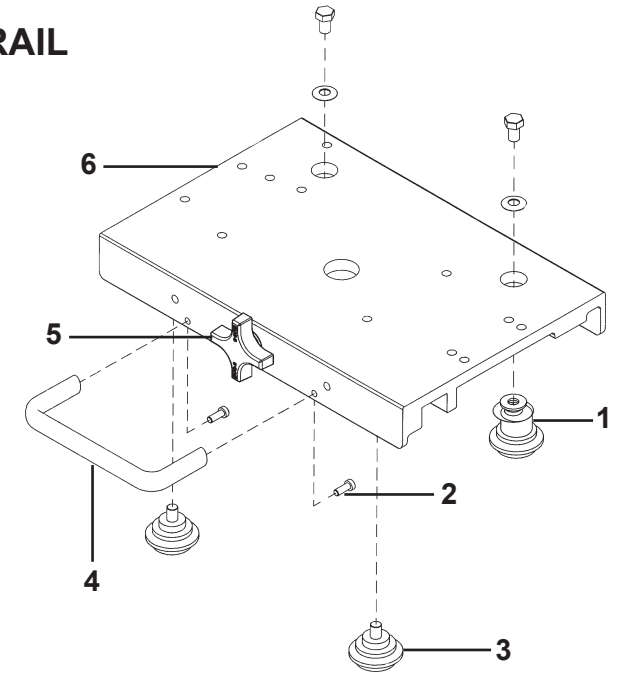

MPD-1055 CARRIAGE 18" (457 mm) 150 lb (68 kg) Carrying Capacity

PARTS LIST / EXPLODED VIEW

ITEM	QTY	PART NO.	DESCRIPTION
1	3	BUG-1984	External Adj Leg & Wheel Assembly
2	3	BUG-2956	Fixed Leg & Wheel Assembly
3	4	FAS-0545	Soc Hd Cap Scr 10-32 x 1/2 Lg
4	2	MPD-1049	Handle, Black
5	1	MPD-1055-PNT	Carriage 18" (457 mm), Painted

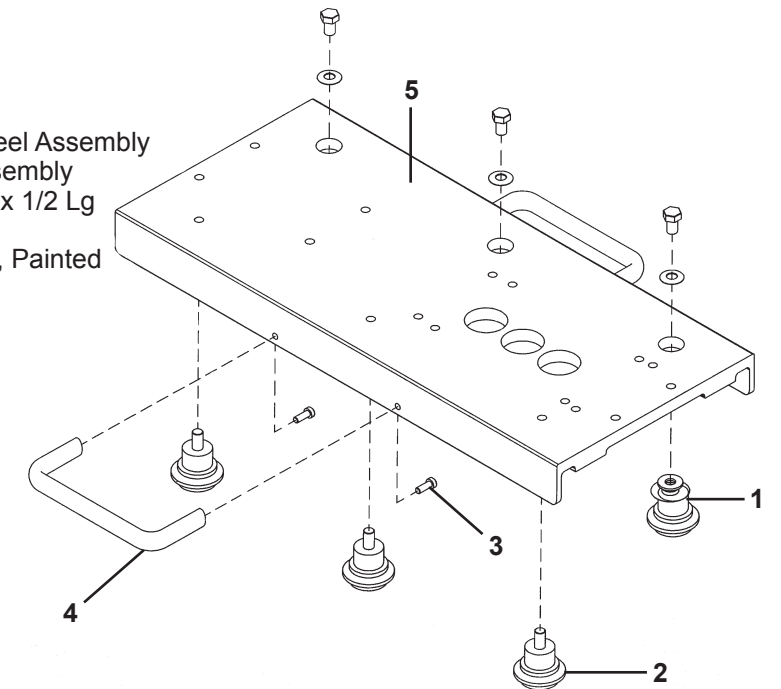

DETAILED SETUP

1. Install Rail

The Tube Carriage is designed for use with Bent Rigid Rail (BRR) or Ring Rail. The exact outside diameter (OD) of the work piece, including coating, must be known when ordering rail. Minimum pipe OD is 9 inches (229 mm). Rail is custom bent for each OD and features adjustable feet to accommodate pipe ovality and deviations in coating thickness.

2. Secure Carriage on Rail

- Select the correct pair of holes on each side of the carriage for the rail diameter being used (see chart, below). If the wheels are not attached to the correct set of holes, remove the wheel brackets and bolt them in selected holes. Tighten the bolts until the brackets are snug but still free to rotate.
- Loosen the adjustment knob to separate the two halves of the split carriage. Loosen and turn the clutch knob counterclockwise to put the drive in the declutched position.
- Place the carriage on the ring rail with the wheels in the rail grooves. Close the cam handle and move the carriage back and forth a few inches. The wheels on their mounting brackets will align themselves correctly with the rail grooves.
- Verify that wheels are properly aligned, then tighten the wheel mounting bolts to lock them in position. Rotate the clutch knob clockwise to engage the drive pinion with the rack.
- Verify that pinion is properly engaged in rack. The correct wheel position will provide a minimum of 1/8" (3.175 mm) engagement between the drive pinion and the gear rack.

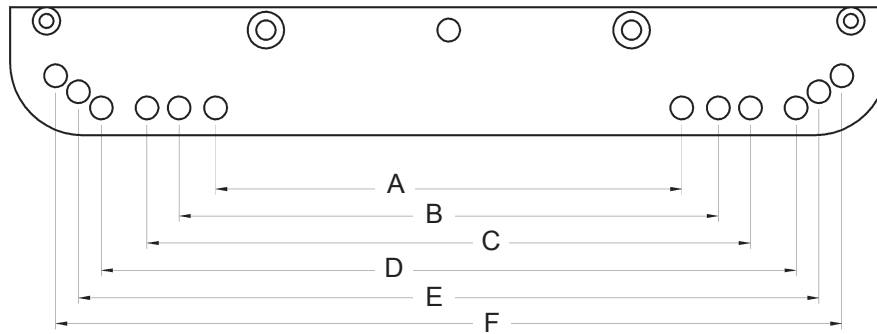

Carriage Wheel Hole Set	BRR-1210 Rail ID		Pipe OD	
	in	mm	in	mm
A	20 - 25	500 - 635	9 - 21	230 - 530
B	23 - 35	585 - 890	12 - 31	300 - 790
C	30 - 44	760 - 1120	18 - 40	455 - 1015
D	41 - 60	1040 - 1525	29 - 54	735 - 1375
E	75 - 174	1905 - 4420	64 - 170	1625 - 4320
F	flat rail		flat rail	

- Notes:**
- Chart values are for reference only
 - Pinion height may need to be adjusted for some rail or pipe sizes.

3. Position and Clamp Welding Gun

Secure welding gun in the all-position clamp located on the end of the height control mechanism. Arrange cables so that they do not interfere with the movement of the machine and secure in the cable anchor at the back of the machine.

MDS-1055 UNIVERSAL LIMIT KIT

The MDS-1055 Universal Limit Kit is an accessory that installs between the Master Drive Unit and any of the three control modules: the *MDS-1002 Straightline, the MDS-1003 Stitch and the MDS-1005 Weaver Control Module. This limit kit adds the ability to CYCLE between limits, STOP AT LIMIT, or RAPID RETURN. All existing functions of the control modules are maintained.

CYCLE MODES:

- a) **CYCLE** - Cycles between two limits. Limit contact does not turn off the weld contactor.
- b) **STOP AT LIMIT** - Limit contact in the direction of travel set by the control module Carriage Travel Switch will stop motion and turn off the weld contactor. The Carriage Travel Switch will reverse the travel direction and start motion away from the contacted limit. The weld contactor will not automatically turn back on when the machine exits a limit.
- c) **RAPID RETURN** - The machine will run at the preset welding speed in the direction set by the Carriage Travel Switch on the control module until it hits a limit. When this limit is hit, the machine will turn off the weld contactor, reverse direction, and travel at full speed to the opposite limit. Upon reaching the limit, the machine stops.

*FMD-1055 For use on Hi-Flex Rail Only.

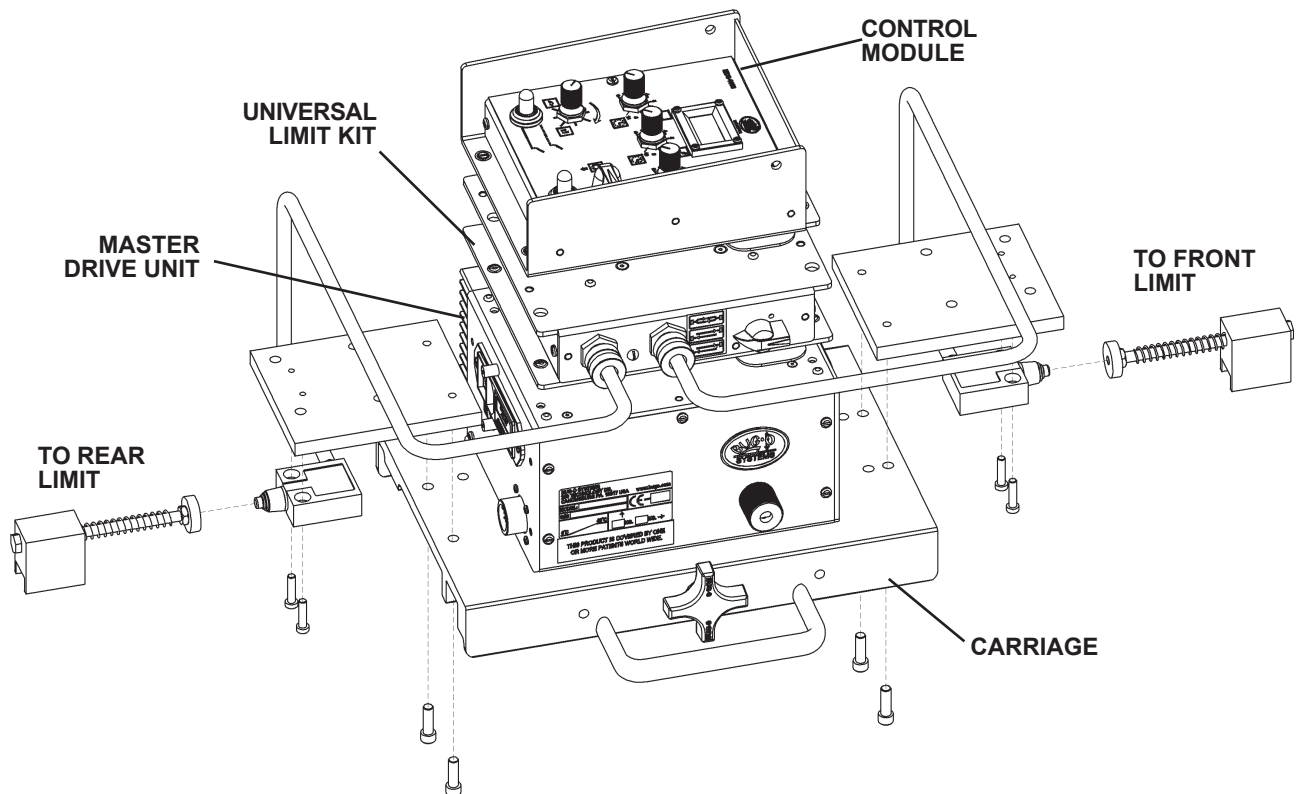

MDS-1060-__ REMOTE CONTROL CABLE

MDS-1060-10 10' (3 m) REMOTE CONTROL CABLE

MDS-1060-25 25' (7.6 m) REMOTE CONTROL CABLE

The optional Remote Control Cable allows the operator to perform work in confined areas where it is difficult to reach the controls. To use the remote cable, detach the control module from the master drive. Fasten the Master Drive Adaptor Plate to the drive unit using the four 8-32 x 3/8 long captive screws provided with the remote cable. Attach the Control Module Adaptor Plate to the control module using the control module's captive screws. The Master Drive Unit is now ready for remote control.

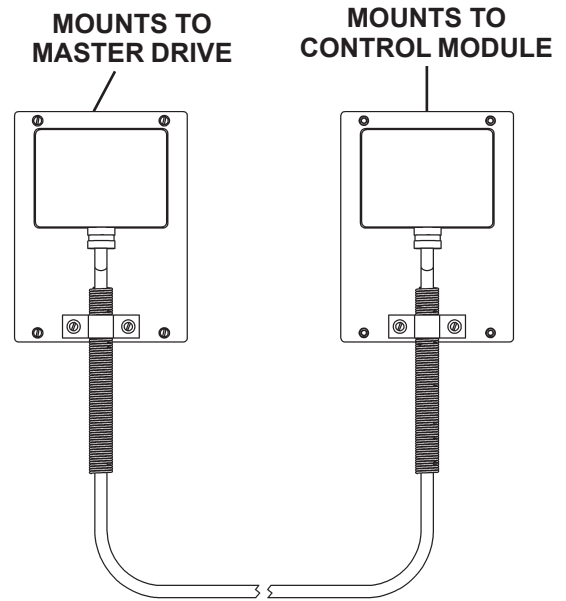

CAS-20__ AUTOMATIC HEIGHT CONTROL

CAS-2050 AUTOMATIC HEIGHT CONTROL / Linear Weaver

The CAS-2050 is an Automatic Height Control (AHC) for the Linear Weaver (WPD-1100) that controls the welding tip to work distance and maintains a constant weld current, helping to provide uniform weld penetration. The CAS-2050 senses the actual weld current, compares this value to the set point, and raises or lowers the welding gun accordingly.

CAS-2060 AUTOMATIC HEIGHT CONTROL / Pendulum Weaver

The CAS-2060 is an Automatic Height Control (AHC) for the Pendulum Weaver (WPD-2100) that controls the welding tip to work distance and maintains a constant weld current, helping to provide uniform weld penetration. AHC senses the actual weld current, compares this value to the set point, and raises or lowers the welding gun accordingly. It features a built-in time delay after the arc is struck, and automatically shuts off when the current drops too low (generally below 60 amps).

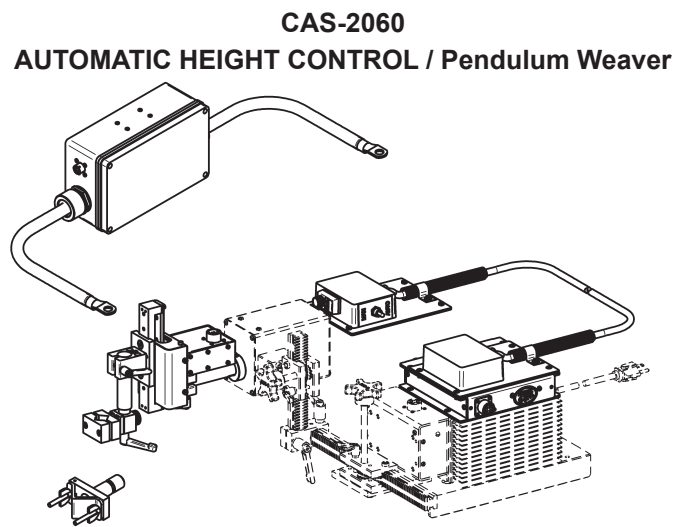
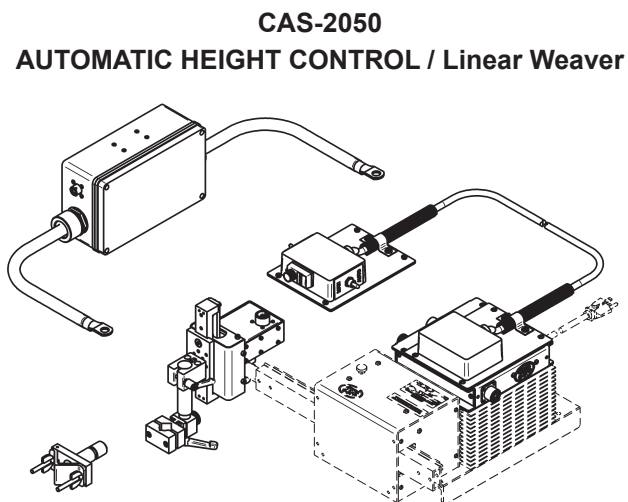

MODULAR DRIVE ACCESSORIES

FOR STRAIGHT LINE CUTTING:

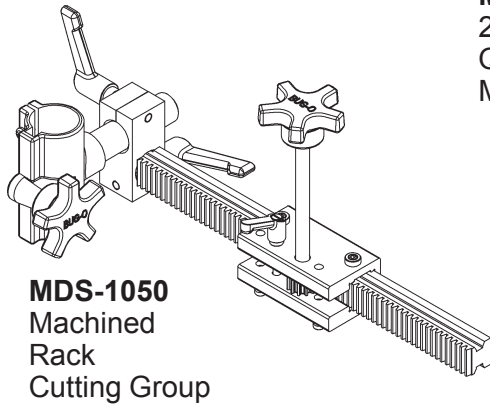

MDS-1050
Machined
Rack
Cutting Group

MDS-3025
2-Hose
Quick-Acting
Manifold

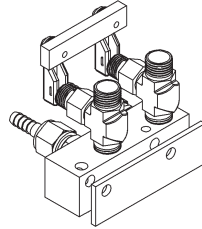

MDS-9898
3-Hose
Quick-Acting
Manifold

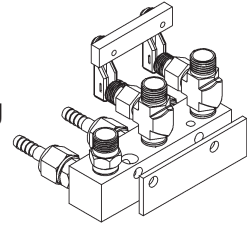

CIR-1010-3
Twin Hose
Assembly
32" (813 mm)

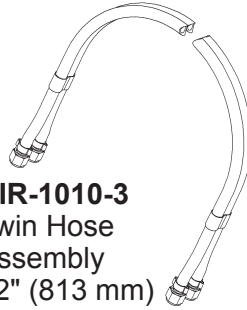

MUG-1119-32
3-Hose
Assembly
32" (813 mm)

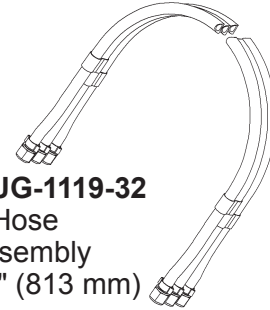

FOR STRAIGHT LINE AND STITCH WELDING:

MDS-1040
Machined Rack
Welding Group

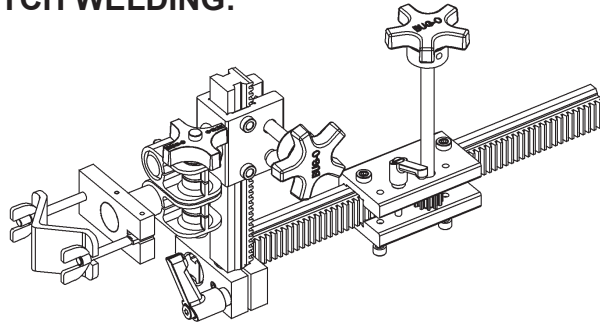

FOR ALL APPLICATIONS:

MPD-1065
Releasable
Carriage
12"
(305 mm)

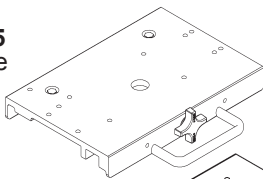

MPD-1055
Carriage
18"
(457 mm)

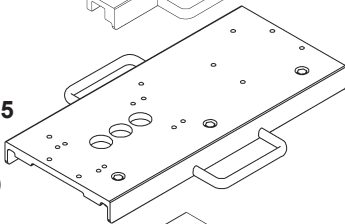

BUG-2205
Carriage
Trailer with
Hitch

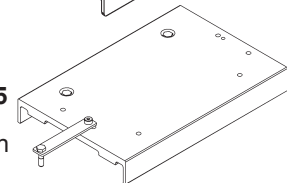

MDS-1045
Extended
Mounting
Plate

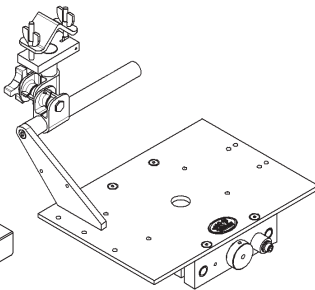
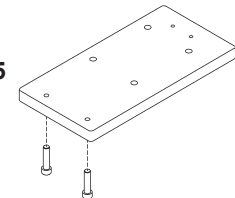

FMD-1105 Drive Carriage
with cable anchor for MDS
Master Drive or Universal
Bug-O-Matic on High-Flex Rail

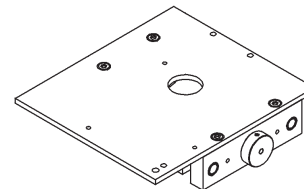

FMD-1150 Hi-Flex Carriage
for DC-III Drive

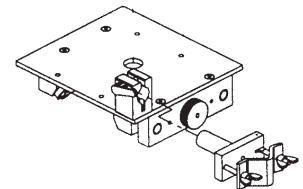

FMD-1100 Drive Carriage
• Used when oscillation is
not required

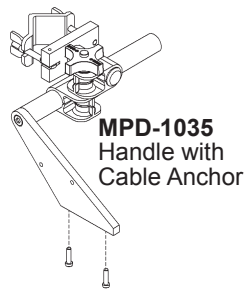

MPD-1035
Handle with
Cable Anchor

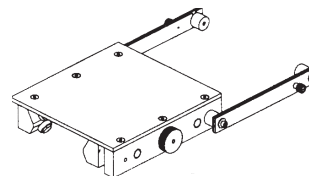

FMD-1090 Long Trailer
For use w/ FMD-1100
• Used to carry accessories,
wire feeder, etc.

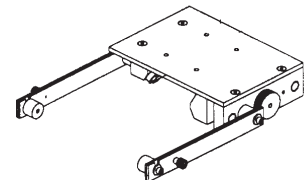

FMD-1095 Short Trailer
For use w/ FMD-1100
• Used to carry accessories,
wire feeder, etc.

ALUMINUM RIGID RAIL

ALUMINUM RIGID RAIL is a high quality alloy, rigid section made to the machine tool tolerance shown in the sectional view below. The carriage drive pinion meshes with a machined gear rack that is mounted on the rail. The wheels of the carriage travel in opposed grooves at either side of the rail, locking the carriage to the rail. Heavy duty [H.D.] aluminum four-legged rigid rail is supplied in two lengths: ARR-1080 [93-1/2" (2.37 m)] called 8' (2.37 m) rail and ARR-1085 [46-1/2" (1.18 m)] called 4' (1.18 m) rail - see insert below. Extra heavy duty aluminum four-legged rigid rail: ARR-1250 [93-1/2' (2-37 m)] called 8' (2.37 m) rail and ARR-1200 [46-1/2" (1.18 m)] called 4' (1.18 m) rail, is also available.

NOTE: 8' Rails accept up to 8 supports, 4' Rails accept up to 4 supports.

RAIL FOR LONGER SPANS:

When unsupported rail paths longer than 93-1/2" (2.37 m) nominal 8' (2.37 m) rail are required, multiple sections of standard rail are mounted on plate, channel or box sections.

ARR-1080 / H.D. ALUMINUM RIGID RAIL 8' (2.37 m)

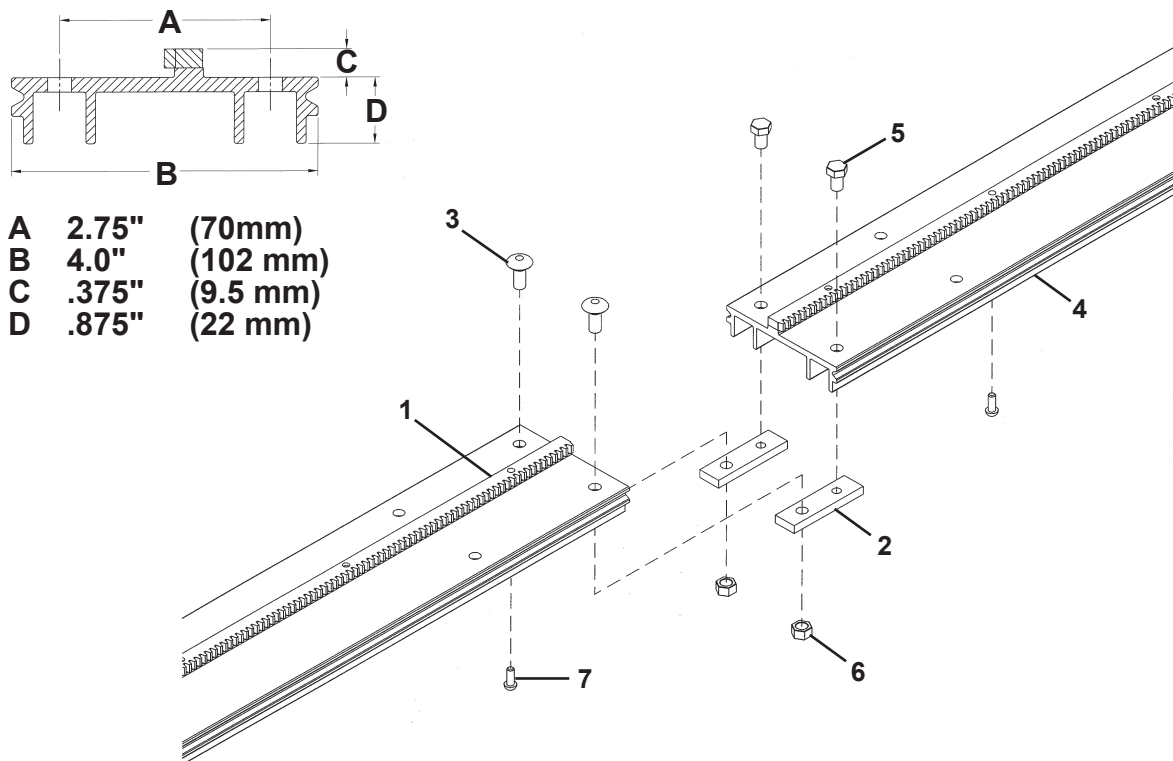

PARTS LIST

<u>ITEM</u>	<u>QTY</u>	<u>PART NO.</u>	<u>DESCRIPTION</u>
1	1	ARR-1006	Rack
2	2	ARR-1027	Splice Bar
3	2	ARR-1028	Carriage Soft
4	1	ARR-1081	Rail-Extrusion
5	2	FAS-0375	Hex Hd Cap Scr 5/16-18 x 1/2
6	2	FAS-1370	Hex Nut 5/16-1 8
7	16	FAS-1445	S.T. Pan Hd Scr 10-32 x 1/2

SEMI-FLEX RAIL

SEMI-FLEX RAIL can be bent inside or outside to a minimum radius of 15' (4.6 m) or 30' (9.1 m) diameter without permanent deformation.

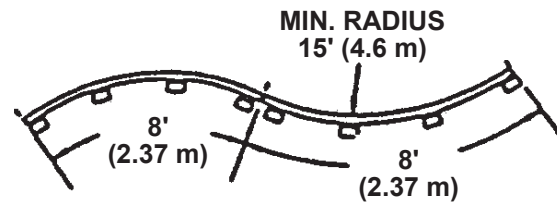

AFR-3000 SEMI-FLEX RAIL replaces the old AFR-1000, 1010, 1020 and the later AFR-2000 rails. All the rack-mounting holes on the AFR-3000 Semi-Flex Rail are slotted so that the rack can slide along the rail. The length of the slots has been increased so that the rails can now be leapfrogged around a complete circle. The tension of the screws holding the rack on the rail is adjusted so that the rack can be moved along the rail with the AFR-2001 Rack-Adjusting Tool.

NOTE: Use at least four attachments (magnets or vacuum cups) on each SEMI-FLEX RAIL.

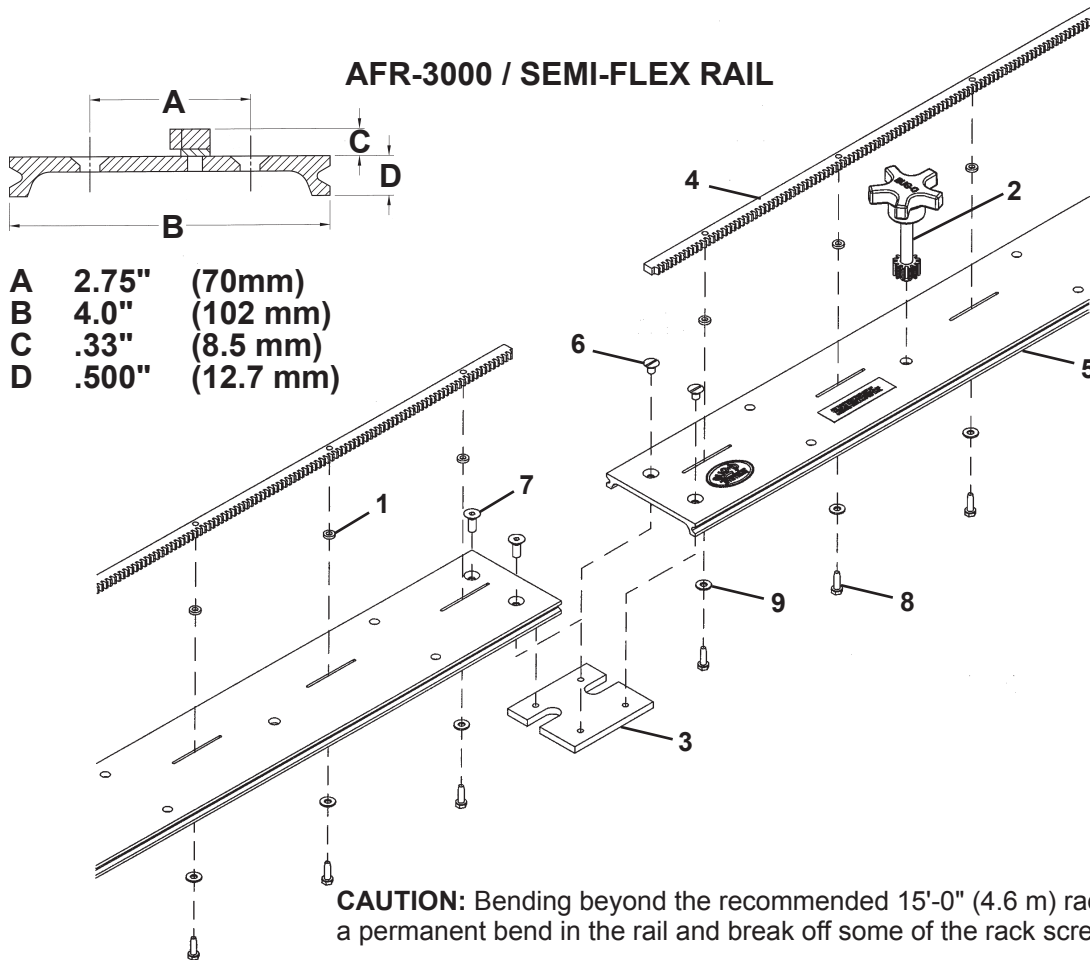

PARTS LIST

<u>ITEM</u>	<u>QTY</u>	<u>PART NO.</u>	<u>DESCRIPTION</u>
1	16	AFR-1015	Spacer Washer
2	1	AFR-2001	Rack Adjusting Tool
3	1	AFR-3002	Splice Plate
4	1	AFR-3006	Rack
5	1	AFR-3009	Extrusion, Punched
6	2	FAS-0855	Flt Hd Soc Scr 1/4-20 x 1/2
7	2	FAS-0955	Flt Hd Soc Scr 1/4-20 x 1/2
8	16	FAS-1446-HW	S.T. Slotted Hex w/Washer 10-32 x 5/8
9	16	WAS-0230	#10 Washer

HI-FLEX RAIL

The **FMD Hi-Flex Rail** can flex from a straight to a 30" (760 mm) radius inside or outside. The rail is made from a tempered, wear resistant, stainless steel with a steel rack. It is designed for use with the FMD Hi-Flex Carriage. The rail comes in 57.7" (1.47 m) lengths and can be held in place with magnets or vacuum cups. An optional stiffener can be installed behind the rail for heavy duty, straight line applications.

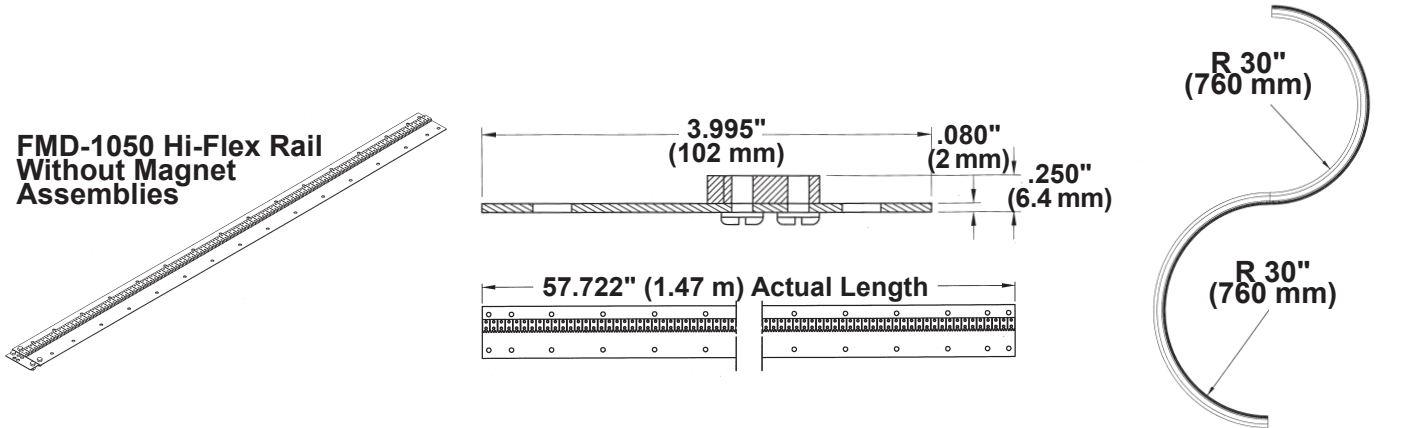

FMD-1050 Hi-Flex Rail Without Magnet Assemblies

FMD-2155 Hi-Flex Rail with 8 Permanent magnets

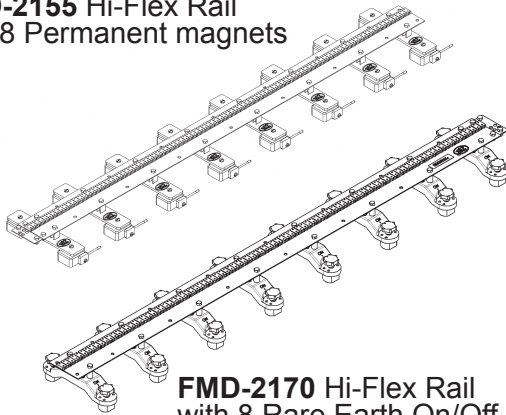

FMD-2170 Hi-Flex Rail with 8 Rare Earth On/Off magnets

FMD Hi-Flex Rail can flex inside or outside to a minimum radius of 30" (760 mm).

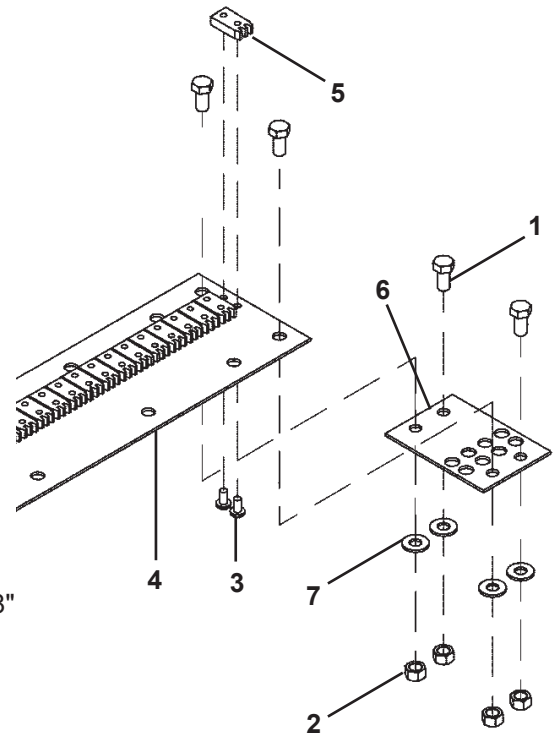

<u>ITEM</u>	<u>QTY</u>	<u>PART NO.</u>	<u>DESCRIPTION</u>
1	4	FAS-0376	Hex Hd Cap Scr 5/16-18 x 5/8"
2	4	FAS-1370	Hex Nut 5/16-18
3	196	FAS-1444	Phil Pan Hd Scr 10-32 x 3/8"
4	1	FMD-1051	Track 5' 17-4 Stainless .077
5	98	FMD-1052	Rack Section, 3 Teeth
6	1	FMD-1053	Flex Rail Splice Plate
7	4	WAS-0250	5/16 Sae Washer

STANDARD MAGNET ASSEMBLIES

MAGNET PLATE ASSEMBLIES mount ARR rail quickly and conveniently right on the work surface. Magnets cannot exert maximum pull on dirty material. Remove excessive paint, scale and rust from the area on which the magnets will be placed.

KEEP MAGNETS CLEAN - before positioning, wipe off magnetic particles which adhere to the poles.

For **MAXIMUM HOLDING POWER** on swivel magnets, press down on top of each side of magnet.... then rotate until it holds firmly. The magnet will retain its magnetism indefinitely - to preserve the magnet casing, keep torch 4" (101 mm) away from magnets when burning/welding. Use various thicknesses of keepers to decrease the magnetic pull when required.

R.E. On/Off Magnets

The New, Bug-O/ Mag-switch, Switchable On/Off Rare-Earth magnet assembly provides for quick rail positioning without fighting the magnet. The lighter weight, at just 1.7 lb. (.77 kg), less than all other magnet assemblies, improves handling. 200 lb (90 kg) holding capacity.

*All **XXX-2010-HH** are "High Heat" models and are rated at 180°C (356°F) for high temperature applications.

Swivel Magnets

Magnet bar, swivel with release; recommended for all applications, combines maximum strength and versatility. This assembly holds up to 250 lbs. (113 kg) on a flat, clean steel surface.

Short Swivel Magnets

Magnet bar, short; compact for positioning in hard-to-reach or restricted areas. This assembly holds up to 200 lbs. (91 kg) on a flat, clean steel surface.

For Aluminum Rigid Rail

R.E. On/Off Magnet

ARM-2010
ARM-2010-HH*
Holding Power
250 lb. (113 kg)

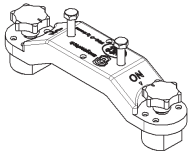

Magnet Plate, Short

ARM-2248
Holding Power
200 lbs. (91 kg)

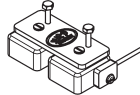

Fixed Magnet w/ Release

ARM-2265
Holding Power
200 lbs. (91 kg)

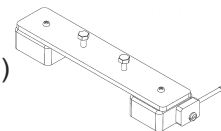

Swivel Magnet w/ Release

ARM-2325
Holding Power
250 lbs. (113 kg)

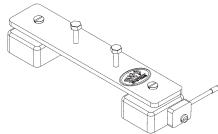

Spacer

ARM-2015
Use with
ARM-2010 only



For Hi-Flex Rail

R.E. On/Off Magnet, Hi-Flex

FMD-2010
FMD-2010-HH*
Holding Power
250 lb. (113 kg)

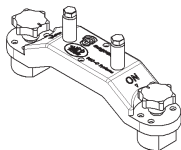

Hi-Flex Magnet w/ Release

FMD-2325
Holding Power
250 lbs. (113 kg)

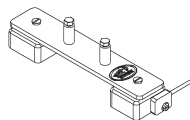

Spacer Bar

FMD-2015
Use with
FMD-2010 only

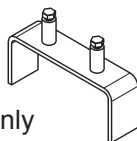

For Semi-Flex Rail

R.E. On/Off Magnet

AFR-2010
AFR-2010-HH*
Holding Power
250 lb. (113 kg)

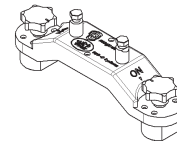

Fixed Magnet w/ Release

ARM-2465
Holding Power
200 lbs. (91 kg)

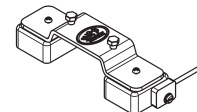

Swivel Magnet w/ Release

ARM-2425
Holding Power
250 lbs. (113 kg)

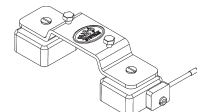

VACUUM SUPPORT KIT

The standard Vacuum Support Kit, ARV-1080 consists of four (4) bars (with 8 cups) and associated hose and fittings. Some applications may require additional ARV-1036 Vacuum Support Bar assemblies.

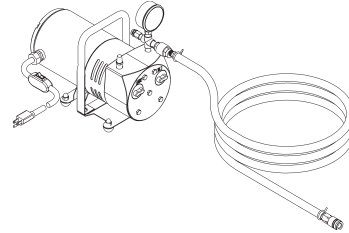
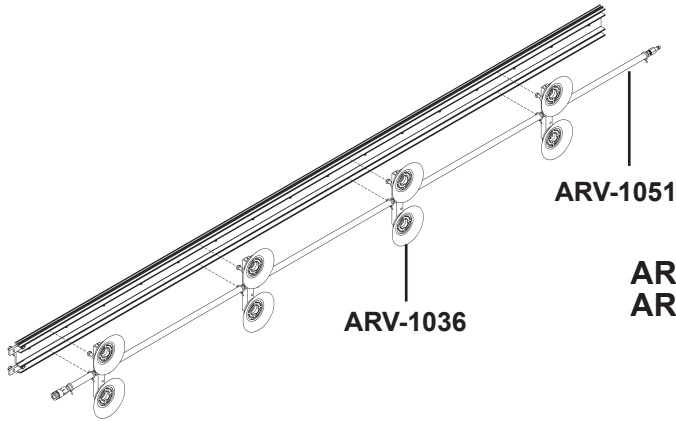

ARV-200 Vacuum Pump Kit 120V
ARV-200 Vacuum Pump Kit 240V

ARV-1036 VACUUM SUPPORT BAR / EXPLODED VIEW / PARTS LIST

VACUUM CUPS are used for mounting the rail to the work piece when magnet bars will not hold.

EXAMPLE: Stainless steel or nonferrous surfaces. The surface must be smooth and nonporous.

Each vacuum bar is fitted with two (2) cups and will exert a maximum pull of 100 lbs. (45 kg).

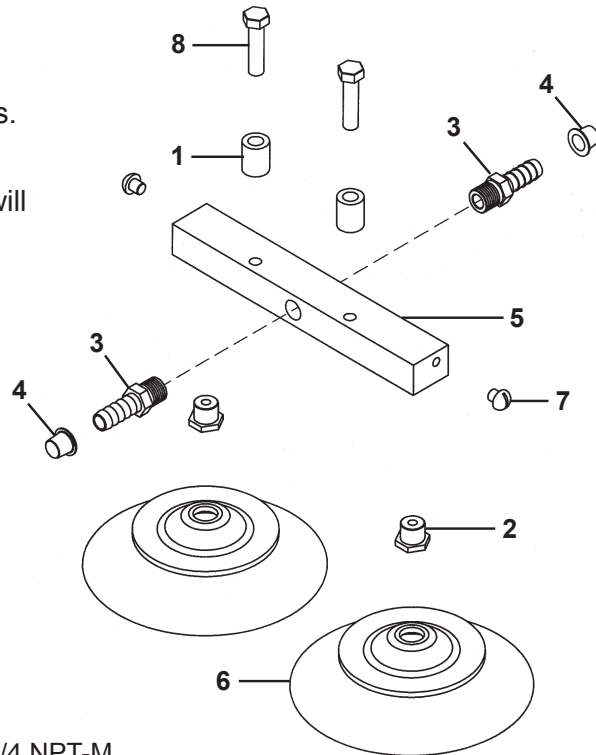

<u>ITEM</u>	<u>QTY</u>	<u>PART NO.</u>	<u>DESCRIPTION</u>
1	2	ARR-9008	Spacer Tube
2	2	ARV-1034	Choke Nipple
3	2	ARV-1107	3/8 Hose Barb x 1/4 NPT-M
4	2	ARV-1109	Protective Cap
5	1	ARV-1111	Support Bar
6	2	ARV-1116	Vacuum Cup (Silicone)
7	2	FAS-0252	Rnd Hd Scr 1/4-20 x 1/4
8	2	FAS-2372	Hex Hd Cap Scr 5/16-18 x 1-1/4

NOTE: Keep flame or arc at least 4"(101 mm) away from vacuum cups. Vacuum cups can be used on preheated material to 600° F (315° C). Each vacuum cup exerts a maximum pull of 50 lbs. (22.6 kg).

VACUUM SUPPORT KIT, CONT'D.

VACUUM PUMP / EXPLODED VIEW / PARTS LIST

ARV-2020 VACUUM PUMP KIT, 120VAC 60HZ/1PH

ARV-2030 VACUUM PUMP KIT, 240 VAC 50 HZ/1PH

The **VACUUM PUMP KITS** are 1/6 HP units that provide 15" (381 mm) Hg on continuous duty. The ARV-2020/2030 Pump will support 30 vacuum cups.

A Repair Kit ARV-1029 is available for the ARV-2020 and ARV-2030 pumps. The kit contains (4) vanes, (1) body gasket, filter felts for the muffler, oiler filter, and oiler wick, a cover gasket and separator felt for the oiler filter.

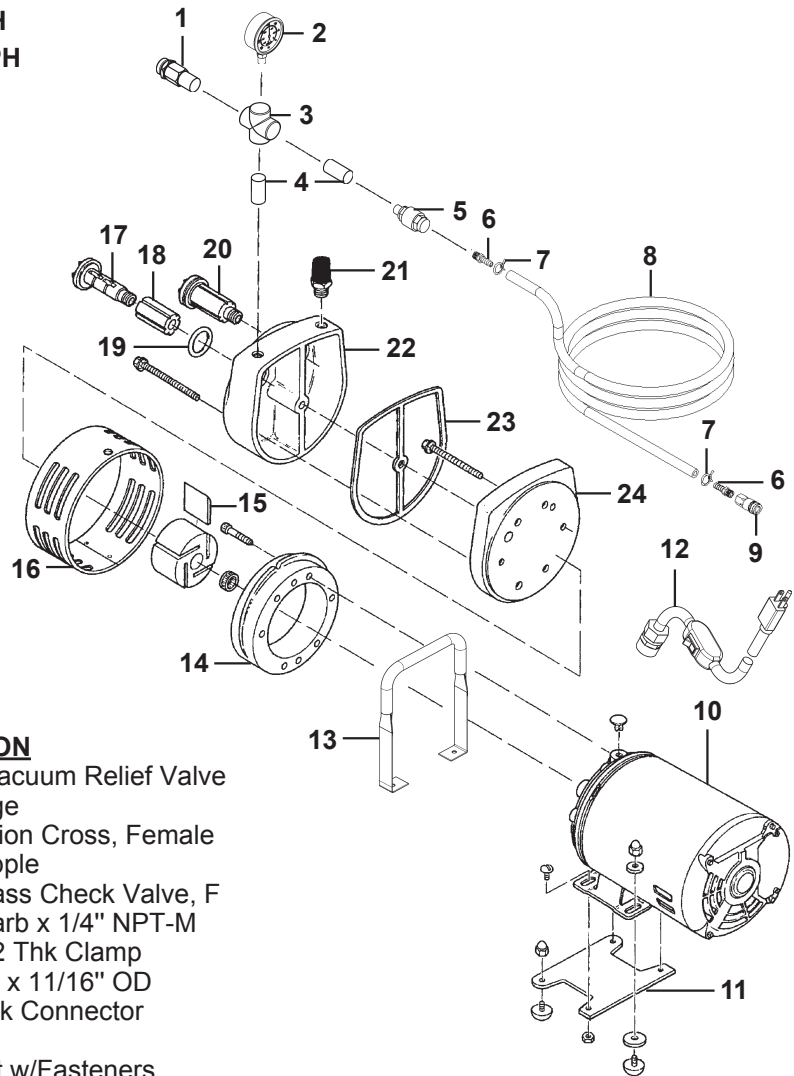

ITEM	QTY	PART NO.	DESCRIPTION
1	1	ARV-2017	1/4" Brass Vacuum Relief Valve
2	1	ARV-2014	Vacuum Gage
3	1	ARV-2018	1/4" NPT Union Cross, Female
4	2	ARV-2012	1/4" NPT Nipple
5	1	ARV-2016	1/4" NPT Brass Check Valve, F
6	2	ARV-1107	3/8" Hose Barb x 1/4" NPT-M
7	2	ARV-1005	11/16" x .112 Thk Clamp
8	1	ARV-1004-P	Hose 3/8" ID x 11/16" OD
9	1	ARV-1012	Female Quick Connector
10	1	ARV-2019	Pump
11	1	ARV-1999	Foot Support w/Fasteners
12	1	ARV-2021	120 VAC Power Cord w/Switch
*			† 240 VAC Replacement Power Components
13	1	ARV-2013	Handle
14	1	ARV-2011	Body
15	4	ARV-2010	Vane
16	1	ARV-2009	Shroud
17	2	ARV-2003	End Cap
18	2	ARV-2004	Felt
19	2	ARV-2005	O-ring
20	2	ARV-2002	End Cap Asmble (Includes parts 17, 18, 19)
21	1	ARV-2001	Filter/Muffler
22	1	ARV-2006	Muffler Box
23	1	ARV-2007	Gasket
24	1	ARV-2008	End Plate

† 240 VAC requires the items below

*	1	BUG-9233	Label, 240 VAC
*	1	BUG-9593	240 VAC Twist Plug
*	1	BUG-9594	240 VAC Connector Body
*	1	ARV-2021	120 VAC Power Cord w/Switch

* Not Shown

MODULAR DRIVE SYSTEM TROUBLESHOOTING GUIDE

The Modular Drive System allows the user to mix and match components to custom build a machine for an application. The resulting ability to replace and remove individual components while troubleshooting significantly reduces the time and effort required to troubleshoot the system. The recommended troubleshooting procedure is as follows:

- 1) Verify that there are no loose electrical or mechanical connections.
- 2) Verify that the welding power source is properly grounded and its ground clamp is attached to the workpiece.
- 3) Ensure the **High Frequency Warnings** in the front of this IPM are not being violated.
- 4) When possible, swap out each component in the system one at a time with a known good component. For example, replace the Control Module on a defective machine with the Control Module from a working machine. Often, this will pinpoint the defective component quickly. If the defective component is a Weaver Drive or a Master Drive, troubleshoot the drive to a circuit board level using step 5 and/or 6 below.
- 5) Remove all attached components. This includes the Remote Control Cable and Universal Limit Kit. All attached components are removed to limit the number of components affecting the operation and complexity of the system. Assemble a base system composed of a Control Module and a Master Drive. Test the base system. If the base system does not work, troubleshoot the base system to a circuit board level using the **Base System Test Procedure**. If possible, test the Control Module by swapping it with a known good Module.
- 6) If the system had a Weaver Drive, install it and retest the system. If the system does not work, troubleshoot the system to a circuit board level using the Base System Test Procedure.
NOTE: The weaver failure can result from a faulty Control Module, Master Drive or Weaver Drive because they all interact. Use the Base System Test Procedure to find the faulty component.
- 7) Some components require special attention when troubleshooting and have their own troubleshooting section. These components are:

Universal Limit Kit (MDS-1055)

Perform any relevant troubleshooting section as required before proceeding to the base system test procedure. The special troubleshooting sections are located after the Base System Test Procedure.

- 8) Finish installing the components one at a time. Test the system after each installation in order to identify the problem components.

TROUBLESHOOTING GUIDE, CONT'D.

PROBLEM	POSSIBLE CAUSE	TEST	BASE SYSTEM TEST PROCEDURE / REMEDY
Speed display is not lit and tractor does not run.	Power switch is OFF.	1A	Turn ON the main ON/OFF switch located in the power entry module. (see Figure 1)
	No power to machine.	1B	Verify the power cord is OK and the correct voltage exists at the outlet.
	Blown fuse.	1C	Unplug the power cord. Check the machine's power input fuse(s). The fuse(s) is located in the power entry module and is accessible without opening the case.
	Faulty accessory attached to the master drive accessory port.	1D	<p>Remove any accessory plugged into the master drive accessory port (see figure 2). Plug in the power cord and turn on the main power.</p> <p>a) If the speed display does not light, proceed with test 1E</p> <p>b) If the speed display lights, install the connector cover on the accessory port. NOTE: FAILURE TO INSTALL THE CONNECTOR COVER ON THE ACCESSORY PORT AFTER COMPLETING THIS TEST MAY CAUSE SERIOUS INJURY FROM ACCIDENTAL ELECTRICAL SHOCK.</p> <p>Set the tractor for continuous forward motion at full speed. If the control module has any type of motion enable switch, turn it to enable.</p> <p>1) If the tractor does not work properly, proceed with step 2A.</p> <p>2) If the tractor operates correctly, the accessory removed from the accessory port is defective.</p>
	Faulty power entry module.	1E	<p>Remove the connector cover or any attached accessory from the master drive accessory port (see Figure 2). Verify the power line voltage is on the two outer pins of the three pin connector (see Figure 2). The center pin is chassis ground.</p> <p>NOTE: INSTALL THE CONNECTOR COVER ON THE ACCESSORY PORT AFTER COMPLETING THIS TEST. FAILURE TO INSTALL THE COVER MAY CAUSE SERIOUS INJURY FROM ACCIDENTAL ELECTRICAL SHOCK.</p> <p>If the voltage is not present, rerun tests 1A, 1B, 1C, 1D and 1E. A second failed 1E test indicates bad internal AC wiring or a defective power entry module. Open the master drive case (see Figure 3). Examine the AC wiring and rewire at fault or replace the power entry module assembly. NOTE: The replacement power entry module is provided with the accessory port's three pin AC connector prewired.</p>
	Defective RFI filter.	1F	Disconnect the two RFI filter output wires (see Figure 1). Turn on the main power. Verify the power line voltage exists on the two output wires. Reconnect the wires. Replace the RFI filter if the power line voltage is not present.

TROUBLESHOOTING GUIDE, CONT'D.

PROBLEM	POSSIBLE CAUSE	TEST	BASE SYSTEM TEST PROCEDURE / REMEDY
	Bad power supply.	1G	<p>Turn on the main power. The green LEDs L1 and L2 (see Figure 1) will light if the power supply is OK.</p> <p>If the LEDs are off, unplug the power supply output connector (see Figure 1). The connector wiring is: White & RED is +15 V DC (+/-2V). White & Black is DC ground. White & Orange is -15V DC (+/-2V). Measure the voltages at the connector.</p> <p>a) A bad voltage indicates a defective supply. Replace the supply.</p> <p>b) Correct voltages indicate the power supply is OK, however, there is a short in the equipment. Plug in the power supply output connector. Perform test 1H.</p>
	Short circuit.	1H	<p>The Green LEDs L1 and L2 will light when the short is removed. Unplug the following and monitor the LEDs to see if the short is removed: 1) The control module 2) The speed card input power connector (see Figure 1). 3) All connectors attached to the interconnect card (see Figure 1), except the connector from the supply.</p> <p>If L1 and/or L2 never turned on, the interconnect card is bad. Replace the board.</p>
No tractor speed control and display is lit.	Operator Error (Stitch Control Module).	2A	<p>Set the MODE switch to CONTINUOUS WELD and the CARRIAGE TRAVEL switch to STOP. Turn the SPEED CONTROL clockwise. Proceed to step 2C if the display does not increase. If the display does increase, then turn the CARRIAGE TRAVEL switch to FORWARD. Open the master drive case (Figure 3) and proceed to step 2D if the tractor does not move forward.</p>
	Operator Error (Weaver Control Module).	2B	<p>Set the MODE switch to RUN , the CARRIAGE TRAVEL switch to STOP and the START/STOP switch to START. Turn the SPEED CONTROL clockwise. Proceed to step 2C if the display does not increase. If the display does increase, then turn the CARRIAGE TRAVEL switch to FORWARD. Open the master drive case (Figure 3) and proceed to step 2D. If the tractor does not move forward.</p>
	Bad DC power.	2C	<p>Open the master drive case (Figure 3). Unplug the power supply output connector (see Figure 1). The connector wiring is: White & Red is +15 V DC (+/-2 V). White & Black is ground. White & Orange is -15 V DC (+/-2 V). Measure the voltages at the connector.</p> <p>A missing or bad voltage indicates a bad supply. Replace the supply.</p>
	Faulty motor wiring.	2D	<p>Check the wires from the speed card to the motor for faults. Rewire if needed.</p>

TROUBLESHOOTING GUIDE, CONT'D.

PROBLEM	POSSIBLE CAUSE	TEST	BASE SYSTEM TEST PROCEDURE / REMEDY
	Faulty motor.	2E	Disconnect the motor leads. Apply 2 to 8 volts DC across the motor leads. Verify that the motor spins.
	Faulty control module, speed card, or motor.	2F	<p>Install one voltmeter lead on TP4 and the other lead on TP5. Turn on the main power. Set the control module for continuous forward tractor motion. If the control module has any type of motion enable switch, turn it to enable. Rotate the tractor speed control knob while observing the voltmeter output. It is possible to vary this voltage between 0 and 8 Volts DC using a good control module.</p> <p>a) If the voltage does not vary, replace the control module card.</p> <p>b) If the voltage does vary, turn the machine OFF and then ON using the main power switch. Observe LED L5. L5 should light for a moment or two during power-up while safety circuits hold the tractor OFF until full power is reached. L5 should then turn off indicating power has been applied to the motor and motion should start.</p> <p>1) If the L5 never lights, replace the speed card.</p> <p>2) If the L5 turns on, turns off, and then turns on again, check for shorted motor connections. If none are found, replace the speed card.</p> <p>3) If the L5 turns on and then stays on, check that the control module is set up as defined above and retest 2F. A second failure indicates a bad speed card.</p> <p>4) If L5 turns on and then off and the motor doesn't start turning, turn the tractor speed up. If the motor does not begin to turn, check the motor to speed card wiring for faults and repair as needed. If the motor still fails to turn, replace the speed card.</p>
Stitch mode on control module does not work.	Bad control module or bad tractor speed card.	3A	<p>If the speed and direction work in CONTINUOUS mode, then the control module is bad.</p> <p>If the speed and direction do not work in CONTINUOUS mode, go to test 2A.</p>
Tractor moves a short distance and then stops.	High Frequency Interference.	4A	Turn off the welder or plasma unit. The unit should operate normally.
	Carrying too much weight.	4B	Verify the load placed on the carriage does not exceed the factory rating.
	Brake is dragging.	4C	Remove the unit from the track and set the controls to forward tractor motion. If the pinion motion stops after a short time, or a check shows that the weight placed on the machine is not excessive, then the problem is most likely brake related. Return the machine for repair.

TROUBLESHOOTING GUIDE, CONT'D.

PROBLEM	POSSIBLE CAUSE	TEST	BASE SYSTEM TEST PROCEDURE / REMEDY
Linear Weaver does not move.	Bad control card or bad weaver.	5A	<p>Set the weaver control module MODE SELECT switch to NO WEAVE and the START/STOP switch to START. Turn the weave speed up to max. Continuously move the STEERING CONTROL knob clockwise and then counter clockwise. This should cause the weaver arm to move back and forth.</p> <p>a) If the arm moves, proceed to step 6A.</p> <p>b) Unbolt and disconnect the weaver box from the modular drive accessory port (see Figure 2). Open the master drive case (see Figure 3). Install one voltmeter lead on TP6 and the other lead on TP7 (see Figure 1). Turn on the unit.</p> <p>Set the weaver control module MODE select switch to RUN (no weave) and the START/STOP switch to START. If the voltage reading is less than 2 V DC, adjust the STEERING pot on the control module until the reading is greater than 2 V DC.</p> <p>1) If the pot adjustment will not produce at least 2 V DC on the voltmeter, replace the control module card.</p> <p>2) If the voltmeter displays above two volts, with or without pot adjustment, replace the weaver speed card.</p>
Linear Weaver moves in one direction only or moves erratically.	Bad control card, bad weaver speed card, or loose set screws on the servo pot's flexible coupling (coupling is used on WPD-1000 only).	6A	<p>On the WPD-1000 linear weaver only, tighten the set screws on the servo potentiometer's flexible coupling. This part can be accessed by removing the WPD-1000 linear weaver's side panel that is located closest to the clutch screw.</p> <p>Set the weaver control module MODE SELECT switch to NO WEAVE and the START/STOP switch to START. Turn the WEAVE SPEED up to max. Continuously move the STEERING CONTROL knob clockwise and then counter clockwise. This should cause the weaver arm to move back and forth.</p> <p>a) If the weaver moves in one direction only, the weaver speed card is bad.</p> <p>b) If the arm weaves but the control module does not function correctly, the control module is bad.</p>
Pendulum Weaver moves in one direction only or moves erratically.	Bad control card or bad speed card.	7A	<p>Set the weaver control module MODE SELECTOR switch to NO WEAVE and the START/STOP switch to START. Turn the WEAVE SPEED up to max. Continuously move the STEERING CONTROL knob clockwise and then counter clockwise. This should cause the weaver arm to move back and forth.</p> <p>a) If the weaver moves in one direction only, the weaver speed card is bad.</p> <p>b) If the arm weaves but the control module does not function correctly, the control module is bad.</p>

TROUBLESHOOTING GUIDE, CONT'D.

PROBLEM	POSSIBLE CAUSE	TEST	BASE SYSTEM TEST PROCEDURE / REMEDY
Pendulum shaft does not move.	Bad control module, damaged power cable, bad speed board or bad capacitor board.	8A	<p>Set the weaver control module MODE SELECT switch to RUN (no weave) and the START/STOP switch to START. Turn the WEAVE SPEED to maximum. Move the STEERING CONTROL knob clockwise and counter-clockwise. This should cause the pendulum shaft to move back and forth.</p> <p>a) If the pendulum output shaft moves, then proceed to step 8A.</p> <p>b) Listen very closely to the Pendulum Gearbox to see if the motor is turning. The gearbox is bad if the motor is turning but the output shaft does not turn.</p> <p>c) Remove the cable from between the electronics box and the pendulum gearbox. Use a meter to verify the connections through the cable. For example, verify pin A to pin A continuity, pin B to pin B, etc.</p> <p>d) Remove the pendulum weaver electronics box from the modular drive accessory port by removing 4 pan head screws (see Figure 2). Open the master drive case (see Figure 3). Install one voltmeter lead on TP6 and the other on TP7 (see Figure 1). Turn on the unit, set the weaver control module MODE SELECT switch to RUN (no weave) and the START/STOP switch to START.</p> <p>If reading is less than 2 V DC, adjust the STEERING pot on the control module until the reading is greater than 2 V DC. Replace the control module if the pot adjustment will not produce at least 2 V DC on the voltmeter.</p> <p>e) Reassemble the master drive case (see Figure 3). Open the pendulum electronics box by removing the 4 pan head screws. Install the back of the electronics box onto the master drive unit. Locate the 2 pin connector on the speed board. Place the voltmeter probes in the connector from the back. Set the control module as follows.</p> <ol style="list-style-type: none"> 1) Set the MODE switch to any mode except RUN (no weave) 2) Set the WEAVE SPEED to 3. 3) Set the WEAVE AMPLITUDE to maximum. 4) Set the RIGHT and LEFT DWELL to minimum. 5) Turn on the main power. Set the STOP/START switch to START to enable weaver motion. <p>If the voltmeter reads 1.5 V DC or more, replace the gear motor box.</p> <p>f) If the voltmeter reading is less than 1 V DC, unplug connector J1 from the speed board. Unplug connector JP1 from the capacitor board and plug it into J1 on the speed board. Redo test 7D.</p>

TROUBLESHOOTING GUIDE, CONT'D.

PROBLEM	POSSIBLE CAUSE	BASE SYSTEM TEST PROCEDURE / REMEDY
Chatter from main drive unit	Clutch improperly engaged	Knob should be seated firmly against drive unit. Turn drive clutch knob fully clockwise while gently rocking the machine forward and backward to fully engage the drive pinion. The rocking motion is necessary to help ensure proper gear mesh (see page 6).
	Wheel engagement knob improperly engaged	Wheel support bar should seat firmly against carriage rib. Turn the wheel engagement knob (A) on the side of the carriage until the wheels are fully moved towards the center of the carriage (engaged) (see page 6).
	Carriage wheels out of adjustment	Follow setup procedure for Wheel Adjustment and Alignment (page 7).
	Worn or damaged rail	Visually inspect for damage or worn part. Replace if necessary.
	Worn or damaged pinion gear	Visually inspect for damage or worn part. Replace if necessary. See Master Drive Unit / Technical Data (page 8).
	Clutch assembly improperly adjusted	Note: This is factory set. Examine all other possibilities first. For proper pinion adjustment, allow 1/16th back lash in drive carriage movement on rail. To increase or decrease pinion engagement, increase or decrease the overall length of the clutch adjustment mechanism by adjusting items #32 and #37 on the MPD-1000 Master Drive Unit Exploded View / Parts List (page 9).

TROUBLESHOOTING GUIDE, CONT'D.

The Modular Drive System is equipped with internal fault diagnostic LEDs and test Points 10 Speed troubleshooting as shown below. Test point evaluation should be performed by a qualified technician using a volt meter. If a qualified technician is not available, return the unit to the factory for repair. Always unplug the power cord before opening the case.

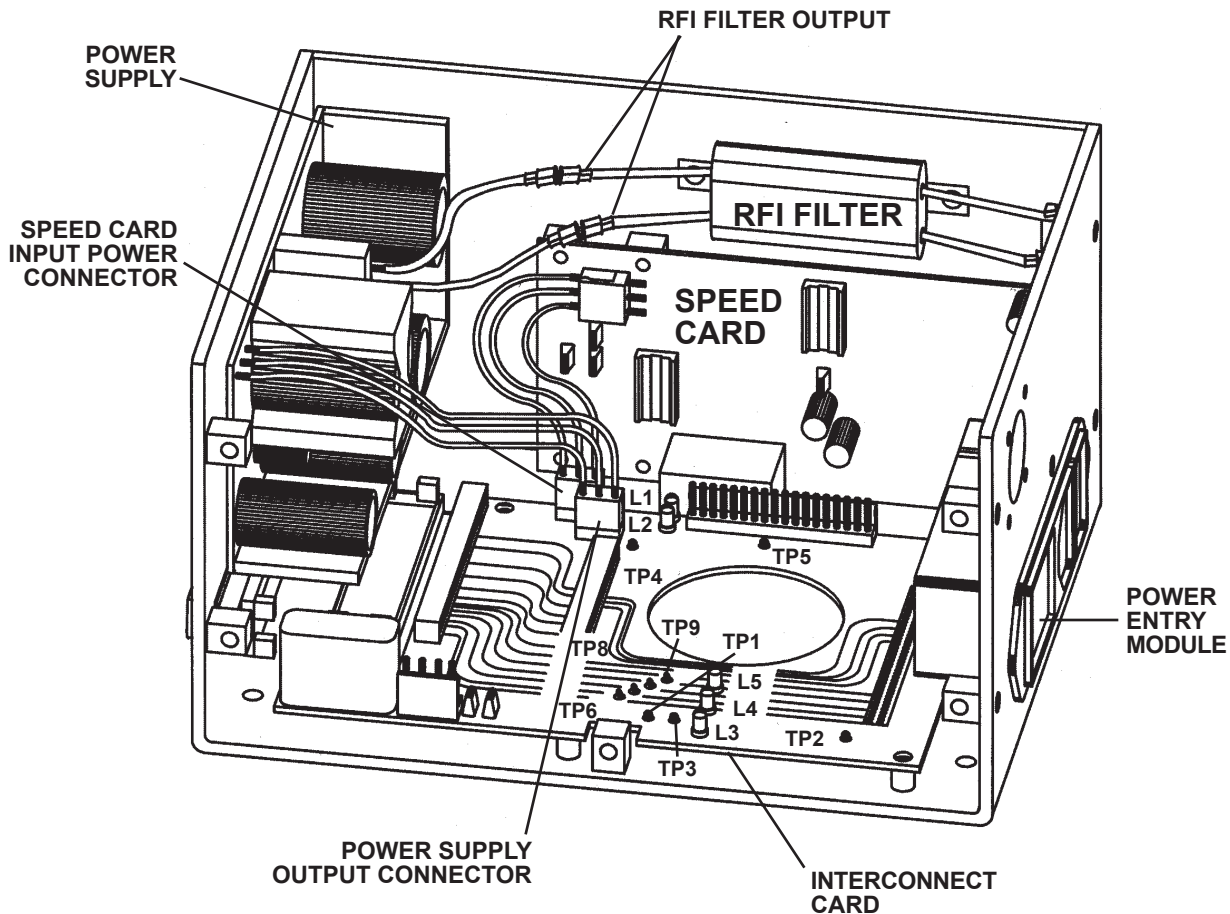

Figure 1. Troubleshooting Test Points

TEST POINTS

TP1	-15V
TP2	GND
TP3	+15V
TP4	Tractor + Speed Command
TP5	Tractor - Speed Command
TP6	Weaver + Speed Command
TP7	Weaver - Speed Command
TP8	Height + Speed Command
TP9	Height - Speed Command

L1	-15v
L2	+15V
L3	Height Off
L4	Weaver Off
L5	Tractor Off

TROUBLESHOOTING GUIDE, CONT'D.

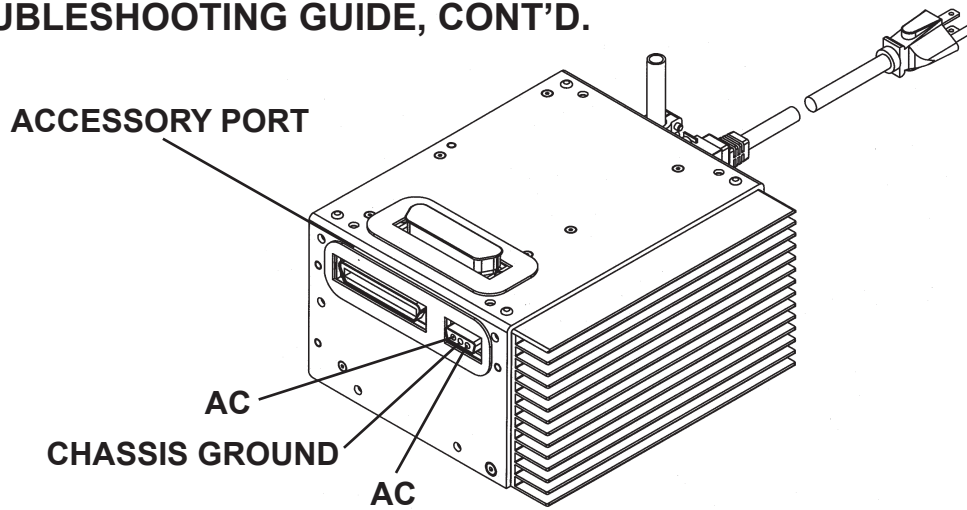
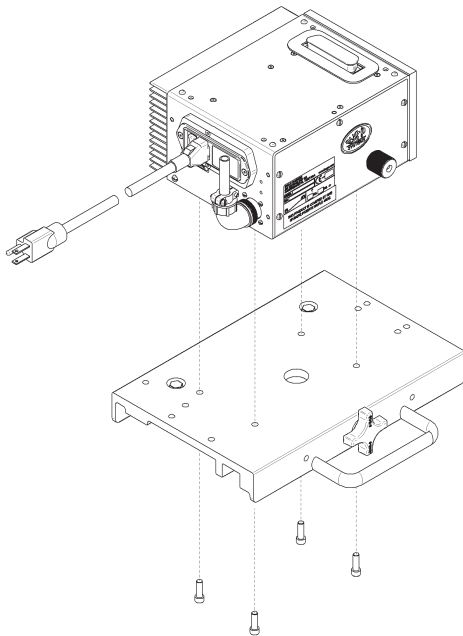

Figure 2. Master Drive Accessory Port

Figure 3. Procedure for Opening the Master Drive Case:

1. Unplug the power cord.



2. Unbolt the Master Drive from the carriage.

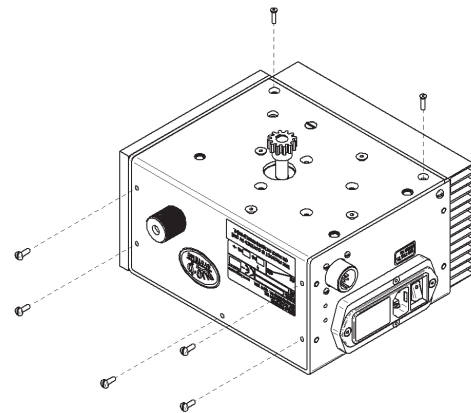

3. Remove ONLY the seven screws as shown.

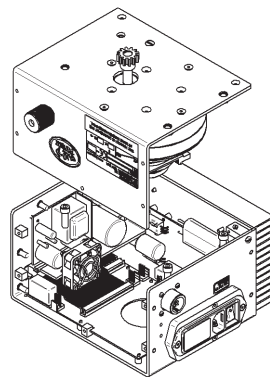

4. Open the case.

CAUTION: UNPLUG THE POWER CORD BEFORE OPENING OR CLOSING THE CASE OR SERIOUS INJURY MAY RESULT.

UNIVERSAL LIMIT KIT TROUBLESHOOTING

This Troubleshooting section details troubleshooting the Universal Limit Kit. See the **Modular Drive System Troubleshooting Guide** for troubleshooting all other components.

Recommended Troubleshooting Procedure:

- 1) If using the Universal Limit Kit with the MDS-1001 Straight Module, the CYCLE SELECTION switch on the Control Module must be in the BASIC FORWARD/REVERSE position for the machine to operate properly.
- 2) Perform steps 1 through 6 in the Modular System Troubleshooting Guide, The Master Drive, Control Module and Weaver Drive must be functioning correctly before proceeding.
- 3) Check for loose or damaged wires both internal and external to the Universal Limit Kit.
- 4) If the machine does not move at all, measure the voltage across each limit switch on the PC board while cycling the switch on and off. The voltage should toggle between 0 and 12V DC. If it does not, the limit switch or limit switch wiring is damaged.
CAUTION: If using the MDS-1001 Straight Module with the Universal Limit Kit, the CYCLE SELECTION switch on the Control Module must be in the BASIC FORWARD/REVERSE position or the machine may not move.
- 5) If the machine turns around, stops, or starts unexpectedly, the Universal Limit Kit may be picking up RF noise from the welder. Move all of the welder cables away from the Universal Limit Kit, the limit switch wires and the Control Module.
- 6) If the previous steps did not fix the Universal Limit Kit, the PCB-1030 card is probably defective. Replace the card.

SPK-1000 MODULAR DRIVE SYSTEM 120V SPARE PARTS KIT / PARTS LIST

<u>PART NO.</u>	<u>QTY</u>	<u>DESCRIPTION</u>
100-0422	1	POWER ENTRY MODULE MOUNTING PLATE
100-0425	1	FILTERED POWER ENTRY MODULE HARNESS
BUG-2959	1	WHEEL ASSEMBLY
BUG-9454	1	V-LOCK 110VAC CORD 2M
MPD-1000	1	HARDWARE KIT
100-0311	2	FLT HD SOC CAP SCR 6-32 x 3/4
FAS-0112	4	PAN HD SLT 6-32 x 1/4 BLACK
FAS-0114	4	PAN HD SCR 6-32 x 3/8 BLACK
FAS-0124	4	8/32 x 3/8 PAN HD, BLK. OXIDE
FAS-0504	4	SOC HD CAP 4-40 x 3/8
FAS-0525	4	SOC HD CAP 8-32 x 1/2
FAS-0557	4	SOC HD CAP 1/4-20 x 3/4
FAS-0815	4	FLT HD SLT SCR 6-32 x 1/2
FAS-0902	4	#4-40 x 1/4" FLAT HD SOCKET
FAS-0905	4	FLT HD SOC SCR #4-40 x 1/2"
FAS-0914	4	#6-32 x 3/8" FLT HD SOCKET
FAS-0923	4	FLT HD SOC SCR 8-32 x 5/16
FAS-130	4	HEX NUT 4-40
GOF-3020	4	SWAGE FASTENER
MDS-103	2	ALUMINUM WASHER
MPD-1036	1	WIRING HARNESS W/4-T CONN (M)
MPD-1058	1	5A SLO-BLO, 5mm x 20mm FUSE
MUG-1617	6	CABLE CONNECTOR, 4-T, F, ELBOW
PCB-1000	1	PRECISION SPEED CARD
PCB-1005-120-24	1	POWER SUPPLY 120 / 240V

SPK-1002 MODULAR DRIVE SYSTEM 240V SPARE PARTS KIT / PARTS LIST

<u>PART NO.</u>	<u>QTY</u>	<u>DESCRIPTION</u>
100-0422	1	POWER ENTRY MODULE MOUNTING PLATE
100-0425	1	FILTERED POWER ENTRY MODULE HARNESS
BUG-2959	1	WHEEL ASSEMBLY
BUG-9454-240	1	V-LOCK POWER CORD, 240V
MPD-1000-HW	1	HARDWARE KIT
100-0311	2	FLT HD SOC CAP SCR 6-32 x 3/4
FAS-0112	4	PAN HD SLT 6-32 x 1/4 BLACK
FAS-0114	4	PAN HD SCR 6-32 x 3/8 BLACK
FAS-0124	4	8/32 x 3/8 PAN HD, BLK. OXIDE
FAS-0504	4	SOC HD CAP 4-40 x 3/8
FAS-0525	4	SOC HD CAP 8-32 x 1/2
FAS-0557	4	SOC HD CAP 1/4-20 x 3/4
FAS-0815	4	FLT HD SLT SCR 6-32 x 1/2
FAS-0902	4	#4-40 x 1/4" FLAT HD SOCKET
FAS-0905	4	FLT HD SOC SCR #4-40 x 1/2"
FAS-0914	4	#6-32 x 3/8" FLT HD SOCKET
FAS-0923	4	FLT HD SOC SCR 8-32 x 5/16
FAS-1305	4	HEX NUT 4-40
GOF-3020	4	SWAGE FASTENER
MDS-1034	2	ALUMINUM WASHER
MPD-1036	1	WIRING HARNESS W/4-T CONN (M)
MPD-1058	6	5A SLO-BLO, 5mm x 20mm FUSE
MUG-1617	1	CABLE CONNECTOR, 4-T, F, ELBOW
PCB-1000	1	PRECISION SPEED CARD
PCB-1005-120-240	1	POWER SUPPLY 120 / 240V

SPK-1004 MODULAR DRIVE SYSTEM 42V SPARE PARTS KIT / PARTS LIST

<u>PART NO.</u>	<u>QTY</u>	<u>DESCRIPTION</u>
100-0422	1	POWER ENTRY MODULE MOUNTING PLATE
100-0425	1	FILTERED POWER ENTRY MODULE HARNESS
BUG-2959	1	WHEEL ASSEMBLY
BUG-9454-42	1	V-LOCK POWER CORD, 42V
MPD-1000-HW	1	HARDWARE KIT
100-0311	2	FLT HD SOC CAP SCR 6-32 x 3/4
FAS-0112	4	PAN HD SLT 6-32 x 1/4 BLACK
FAS-0114	4	PAN HD SCR 6-32 x 3/8 BLACK
FAS-0124	4	8/32 x 3/8 PAN HD, BLK. OXIDE
FAS-0504	4	SOC HD CAP 4-40 x 3/8
FAS-0525	4	SOC HD CAP 8-32 x 1/2
FAS-0557	4	SOC HD CAP 1/4-20 x 3/4
FAS-0815	4	FLT HD SLT SCR 6-32 x 1/2
FAS-0902	4	#4-40 x 1/4" FLAT HD SOCKET
FAS-0905	4	FLT HD SOC SCR #4-40 X 1/2"
FAS-0914	4	#6-32 x 3/8" FLT HD SOCKET
FAS-0923	4	FLT HD SOC SCR 8-32 x 5/16
FAS-1305	4	HEX NUT 4-40
GOF-3020	4	SWAGE FASTENER
MDS-1034	2	ALUMINUM WASHER
MPD-1036	1	WIRING HARNESS W/4-T CONN (M)
MPD-1058	6	5A SLO-BLO, 5mm x 20mm FUSE
MUG-1617	1	CABLE CONNECTOR, 4-T, F, ELBOW
PCB-1000	1	PRECISION SPEED CARD
PCB-1005-42	1	POWER SUPPLY 42 V

BUG-O SYSTEMS INTERNATIONAL

EC DECLARATION OF CONFORMITY

Manufacturer and technical
documentation holder:

Bug-O Systems International
a Division of Weld Tooling Corporation
280 Technology Drive
Canonsburg, PA 15317-9564

Hereby declare that machinery: **Modular Drive System**, including options and accessories

Sales codes: MPD-1000, MPD-1002, MPD-1004, MDS-1002, MDS-1003, MDS-1004, MDS-1005, MDS-1005-DIAL, MDS-1165, BUG-6050, FMD-1090, FMD-1095, FMD-1100, FMD-1105, MPD-1065, BUG-5910, BUG-5960, PSR-1050, MPD-1035, MDS-1050, BUG-5285, MDS-1040, BUG-5275, WPD-2100, CAS-2060, AVC-2060-XX, WPD-1100, AVC-2050-PL-XX, CAS-2050, WPD-1100-40, MDS-1055, FMD-1045
(All of which may also contain prefixes and suffixes)

Kits that include the above: MDS-4000 series Kits
FMD-4000 series Kits
(kits in each series may also contain prefixes and suffixes)

Is in conformity with Council Directives and amendments:

- 2006/42/EC – Machinery Directive
- 2014/35/EU – Electromagnetic Compatibility (EMC) Directive
- 2011/65/EU – Restriction of the use of certain hazardous substances (RoHS)

Standards:

- EN 12100:2010 – Safety of Machinery – General principles for design – Risk assessment and risk reduction.
- EN 60204-1:2016 – Safety of machinery – Electrical equipment of machines Part 1: General Requirements.
- EN 61000-6-2 – Electromagnetic compatibility (EMC) – Part 6-2 Generic standards – Immunity for industrial environments.
- EN 61000-6-4 – Electromagnetic compatibility (EMC) – Part 6-4 Generic standards – Emissions for industrial environments.
- EN 50581:2012 – Technical documentation for the assessment of electrical and electronic products with respect to restriction of hazardous substances.

The machinery, product, assembly or sub-assembly covered by this Declaration of Conformity must not be put into service until the machinery into which it is to be incorporated (if applicable) is declared in conformity with provisions of the applicable directives(s).

Authorized representative for the compilation of the relevant technical documentation and issuer of EC Declaration of Conformity:

Date of Issue: MAY 23, 2019

Place of issue: 280 Technology Drive, Canonsburg, PA 15317, USA

Typed Name of Authorized Person: MATTHEW W. CABLE - PRESIDENT

WARRANTY

Limited 3-Year Warranty

Model _____
Serial No. _____
Date Purchased: _____
Where Purchased: _____

For a period ending one (1) year from the date of invoice, Manufacturer warrants that any new machine or part is free from defects in materials and workmanship and Manufacturer agrees to repair or replace at its option, any defective part or machine. HOWEVER, if the invoiced customer registers the Product Warranty by returning the Warranty Registration Card supplied with the product within 90 days of the invoice date, or by registering on-line at www.bugo.com, Manufacturer will extend the warranty period an additional two (2) years which will provide three (3) total years from the date of original invoice to customer. This warranty does not apply to machines which, after Manufacturer's inspection are determined by Manufacturer to have been damaged due to neglect, abuse, overloading, accident or improper usage. All shipping and handling charges will be paid by the customer.

The foregoing express warranty is exclusive and Manufacturer makes no representation or warranty (either express or implied) other than as set forth expressly in the preceding sentence. Specifically, Manufacturer makes no express or implied warranty of merchantability or fitness for any particular purpose with respect to any goods. Manufacturer shall not be subject to any other obligations or liabilities whatsoever with respect to machines or parts furnished by Manufacturer.

Manufacturer shall not in any event be liable to Distributor or any customer for any loss of profits, incidental or consequential damages or special damages of any kind. Distributor's or customer's sole and exclusive remedy against Manufacturer for any breach of warranty, negligence, strict liability or any other claim relating to goods delivered pursuant hereto shall be for repair or replacement (at Manufacturer's option) of the machines or parts affected by such breach.

Distributor's Warranty:

In no event shall Manufacturer be liable to Distributor or to any customer thereof for any warranties, representations or promises, express or implied, extended by Distributor without the advance written consent of Manufacturer, including but not limited to any and all warranties of merchantability or fitness for a particular purpose and all warranties, representations or promises which exceed or are different from the express limited warranty set forth above. Distributor agrees to indemnify and hold Manufacturer harmless from any claim by a customer based upon any express or implied warranty by Distributor which exceeds or differs from Manufacturer's express limited warranty set forth above.

HOW TO OBTAIN SERVICE:

If you think this machine is not operating properly, re-read the instruction manual carefully, then call your Authorized BUG-O dealer/distributor. If they cannot give you the necessary service, write or phone us to tell us exactly what difficulty you have experienced. BE SURE to mention the MODEL and SERIAL numbers.

