

INSTRUCTIONS AND PARTS MANUAL

K-BUG 3000, K-BUG 3500

K-BUG 3000, K-BUG 3002
K-BUG 3500, K-BUG 3502

Please record your equipment identification information below for future reference. This information can be found on your machine nameplate.

Model Number _____

Serial Number _____

Date of Purchase _____

Whenever you request replacement parts or information on this equipment, always supply the information you have recorded above.

LIT-KBUG-3000-IPM-0325

Bug-O Systems is committed to empowering our customers by providing operator controlled mechanized solutions for their welding, cutting and custom applications.



B U G O S Y S T E M S

A DIVISION OF WELD TOOLING CORPORATION



280 TECHNOLOGY DRIVE CANONSBURG, PENNSYLVANIA 15317-9564 USA
PHONE: 412-331-1776 <https://www.bugo.com> FAX: 412-331-0383

SAFETY

PROTECT YOURSELF AND OTHERS FROM SERIOUS INJURY OR DEATH. KEEP CHILDREN AWAY. BE SURE THAT ALL INSTALLATION, OPERATION, MAINTENANCE AND REPAIR PROCEDURES ARE PERFORMED ONLY BY QUALIFIED INDIVIDUALS.



ELECTRIC SHOCK can kill.

- 1) The equipment is not waterproof. Using the unit in a wet environment may result in serious injury. Do not touch equipment when wet or standing in a wet location.
- 2) The unused connectors have power on them. Always keep the unused connectors covered with the supplied protective panels. Operation of the machine without the protective panels may result in injury.
- 3) Never open the equipment without first unplugging the power cord or serious injury may result.
- 4) Verify the customer-supplied power connections are made in accordance with all applicable local and national electrical safety codes. If none exist, use International Electric Code (IEC) 950.
- 5) Never remove or bypass the equipment power cord ground. Verify the equipment is grounded in accordance with all applicable local and national electrical safety codes. If none exist, use International Electric Code (IEC) 950.

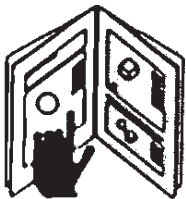

READ INSTRUCTIONS.

Read the instruction manual before installing and using the equipment.



EQUIPMENT DAMAGE POSSIBLE.

- 1) Do not plug in the power cord without first verifying the equipment is OFF and the cord input voltage is the same as required by the machine or serious damage may result.
- 2) Always verify both the pinion and wheels are fully engaged before applying power or equipment damage may occur.
- 3) Do not leave the equipment unattended.
- 4) Remove from the work site and store in a safe location when not in use.



FALLING EQUIPMENT can cause serious personal injury and equipment damage.

Faulty or careless user installation is possible. As a result, never stand or walk underneath equipment.



MOVING PARTS can cause serious injury.

- 1) Never try to stop the pinion from moving except by removing power or by using the STOP control.
- 2) Do not remove any protective panels, covers or guards and operate equipment.

HIGH FREQUENCY WARNINGS

SPECIAL PRECAUTIONS ARE REQUIRED WHEN USING PLASMA, TIG OR ANY WELDING PROCESS THAT USES HIGH FREQUENCY TO STRIKE AN ARC.



WARNING: HIGH FREQUENCY CAN EFFECT MACHINE OPERATION AND THEREFORE, WELD QUALITY.

Read the precautions below before installing and using the equipment.

PRECAUTIONS:

- 1) Some plasma or welding cables are strong sources of high frequency interference. NEVER lay a plasma or welding cable across the controls of the machine.
- 2) Always physically separate the plasma or welding cable leads from the machine cables. For example, the plasma or welding cable leads should NEVER be bundled with a pendant cable or the machine power cord. Maximize the separation between any machine cables and the plasma or welding cables.
- 3) Strictly follow the grounding procedures specified for the plasma or welding unit. NOTE: Some plasma and welding units produce exceptionally large amounts of high frequency noise. They may require a grounding rod be driven into the earth within six feet (2 meters) of the plasma or welding unit to become compatible with an automatic cutting or welding process.
- 4) If the high frequency is produced using a spark gap, adjust the points so the gap is as small as possible. The larger the gap, the higher the voltage and the higher the interference.
- 5) Some plasma or welding units will inject high frequency interference into the AC power line. Use separate power line branches whenever possible to power the plasma or welding source and the machine. Do not plug them into the same outlet box.
- 6) High frequency noise may enter the machine through the plasma or welding supply remote contactor leads. Some plasma and welding sources can produce noise spikes of up to several thousand volts. These sources are not compatible with automated cutting and welding equipment. It is recommended that the remote contactor leads on these plasma or welding sources not be connected to the machine. An alternate solution is to purchase a separate remote contactor isolation box.

K-BUG 3000, K-BUG 3500

K-BUG 3000, K-BUG 3002

K-BUG 3500, K-BUG 3502

INSTRUCTIONS AND PARTS MANUAL

TABLE OF CONTENTS

PAGE

5Introduction
5Features
5Technical Data
5Dimensions
6K-BUG 3500 Introduction and Features
7Illustration of Typical Applications
7Stop Sensor Operation
7Weave Patterns
8User Interface - Control Panel
9User Interface - Wireless Remote Control
9Enabling the Remote Control
10Global Parameters
10Converting Units
11Installation and Operation
11Cable Interconnect Diagram
12Maintenance
12Troubleshooting
14K-BUG 3000 Assembly View
15K-BUG 3000 Assembly View / Parts List
16K-BUG 3000 Wiring Diagram
17KBUG-3060 Control Tower Assembly / Exploded View / Parts List
18KBUG-3010 Carriage Assembly / Exploded View
19KBUG-3010 Carriage Assembly / Parts List
20KBUG-3070 Weaving Assembly / Exploded View / Parts List
20KBUG-3080 Y-Slide Assembly / Exploded View / Parts List
21KBUG-3100 Remote Control / Exploded View / Parts List
21KBUG-3120 Torch Clamp Assembly / Exploded View / Parts List
22KBUG-3130 Guide Roller Assembly / Exploded View / Parts List
23SBG-450-_-_-_- Gun & Cable Assembly / Exploded View / Parts List
24KBUG-3500, K3000 w/Bug-O Rack & Remote / Exploded View / Parts List
25Accessories
27Installation of Guide Rail
28100-0902 KBUG Guide Rail Assembly / Exploded View / Parts List
28100-0910-3000 KBUG Arm Guide Kit
29100-0811 KBUG Long Arm Guide Assembly / Exploded View / Parts List
30100-0817 KBUG Short Arm Guide Assembly / Exploded View / Parts List
31Warranty
32Addendum

INTRODUCTION

The K-BUG 3000 is a highly versatile fillet welder designed for all-position welding and equipped with a pendulum oscillator. The K-BUG 3000 drives on four rubber wheels and utilizes guide arms and a strong magnet in its base to adhere the machine to the work piece.

FEATURES

- Wireless Remote Control
- Digital displays for weld speed, dwell times, weave width and weave speed
- Independent left / right dwell times
- Five weave patterns
- Magnet release for easy positioning of carriage
- Electronics rated to 80 C (175 °F)
- Drive wheels rated to 400 °F (204 °C)

TECHNICAL DATA

Power Input

K-BUG 3000 120V / 50-60 Hz / 1 Phase

K-BUG 3002 240V / 50-60 Hz / 1 Phase

Weight 20 lb (9.2 kg)

Drive Motor 24 VDC, 12 W, 5000 RPM

Travel Speed 1.18 - 35 in/min (3.0 - 88 cm/min)

Torch Holder Fits barrels up to 0.75 in (19 mm)

Torch Angle Adjustable

Running Angle 90°

Y-Stroke 0 - 0.78 in (0 - 20 mm)

Weave Speed to 188 in/min (478 cm/min)*

Weave Width to 1.05 in (26.67 mm)*

Dwell Time 0 - 9.9 sec.

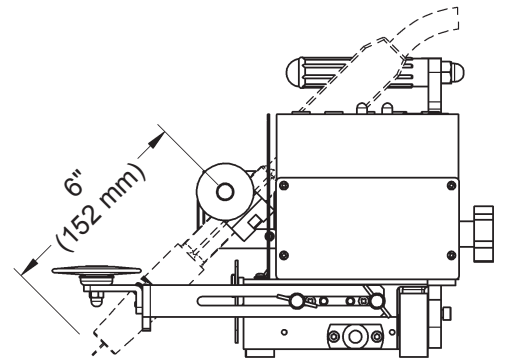

* When torch Pivot-to-Tip length is 6.0 in (152 mm), as shown at right.

Increasing the Pivot-to-Tip length will increase the maximum speed and the weave width.

DIMENSIONS



Bug-O Systems has a complete overview video of our K-BUG 3000. To watch this video, scan the qr code or visit: <https://www.youtube.com/watch?v=lx4LU2J48g8&t=94s>

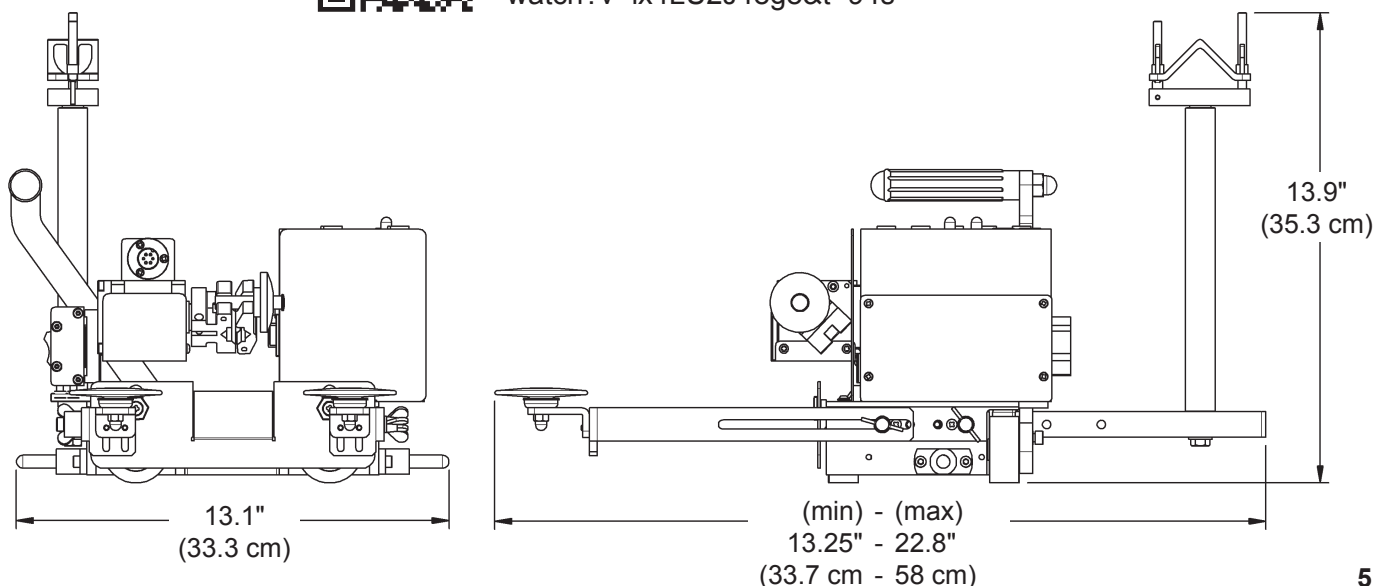

K-BUG 3500

INTRODUCTION

The K-BUG 3500 is a modified version of the KBUG-3000. It provides the same pendulum oscillator functions, the same firm magnetic base and all the same control functionality as the KBUG-3000. The positioning of the oscillator gearbox on the KBUG-3500 is improved with the addition of the familiar Bug-O Systems machined racking. This racking, with greater envelope of motion, allows the oscillator gearbox to be located for both fillet and butt welds. The limit switches on the KBUG-3500 tractor are also extended to allow access beneath the larger Bug-O racking. This improved racking also allows the KBUG Guide Rail Followers to be installed (see Accessories).

The KBUG-3500, in conjunction with the Guide Rail, provides a solution for the welding of butt joints with rapid installation without the requirements for a rigid track.

FEATURES

- Wireless Remote Control
- Digital displays for weld speed, dwell times, weave width and weave speed
- Independent left / right dwell times
- Five weave patterns
- Bug-O Machined Racking
- Extended Limit Switches
- Guide Rail Followers can be installed
- Magnet release for easy positioning of carriage
- Electronics rated to 80 C (175 °F)
- Drive wheels rated to 400 °F (204 °C)

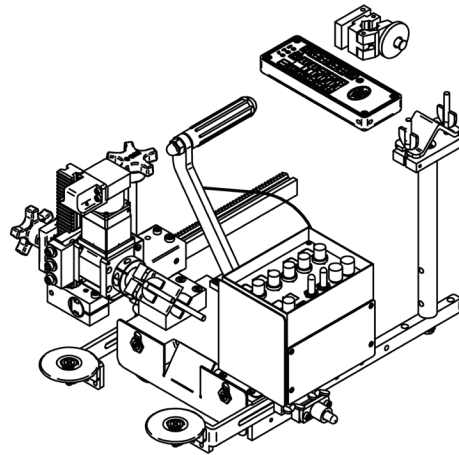

Add these accessories to your base machine for KBUG-3000 or KBUG-3000-BAT

- KBUG ARM GUIDE KIT - 100-0910-3000
This includes all hardware needed to be mounted to KBUG-3000/KBUG-3000-BAT
- KBUG GUIDE RAIL ASSEMBLY (6 FT LONG) - 100-0902
This includes a complete rail assembly, but does not include hardware that needs to be installed on our machines.
- KBUG-3000 to KBUG-3500 CONVERSION KIT - 100-1002
(To convert a KBUG-3000 or KBUG-3000-BAT to a KBUG-3500 or KBUG-3500-BAT)*

*Not all KBUG-3000 or KBUG-3000-BAT work with the 100-1002. Please consult factory.

ILLUSTRATION OF TYPICAL APPLICATIONS

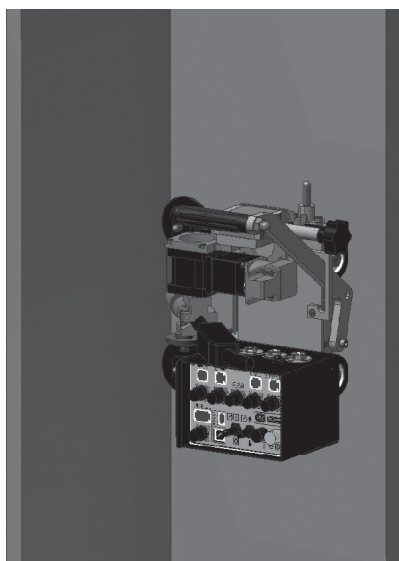

Vertical Fillet Welding

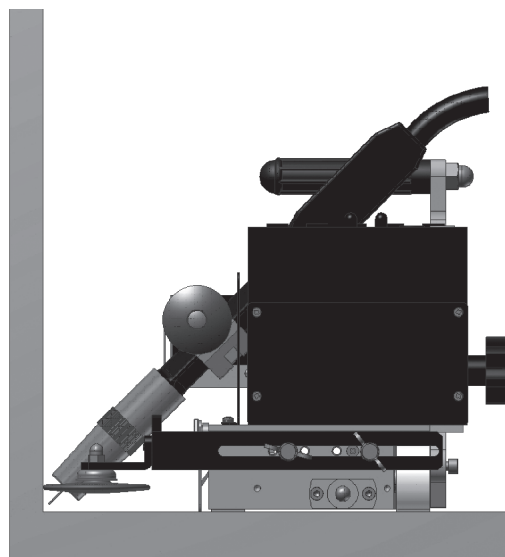

Downhand Fillet Welding

STOP SENSOR OPERATION

The K-BUG 3000 is equipped with two (2) Stop Sensors. One sensor is placed on the right side of the carriage, the other is placed on the left. The Stop Sensors are normally open switches that engage or close when depressed. If a sensor is tripped during welding, carriage travel will immediately stop and Crater Fill will be performed. Remove the obstacle to reset the Stop Sensor. Press Cycle Start Button to begin weld cycle again.

WEAVE PATTERNS

Symbol	Number	Name	Description
—	1	No Weave	Performs straight-line (linear) weld.
∩	2	Run	Tractor moves continuously -- during weave and dwell.
∩∩	3	Stop on Dwell	Tractor moves during weave and pauses on dwell.
∩∩∩	4	Step	Tractor pauses during the weave and travels during the dwell.
∩∩∩	5	Saw Tooth	Tractor pauses while weave moves <i>away</i> from tractor, then tractor moves while weave moves <i>toward</i> the tractor. Tractor pauses on dwell.

USER INTERFACE - CONTROL PANEL

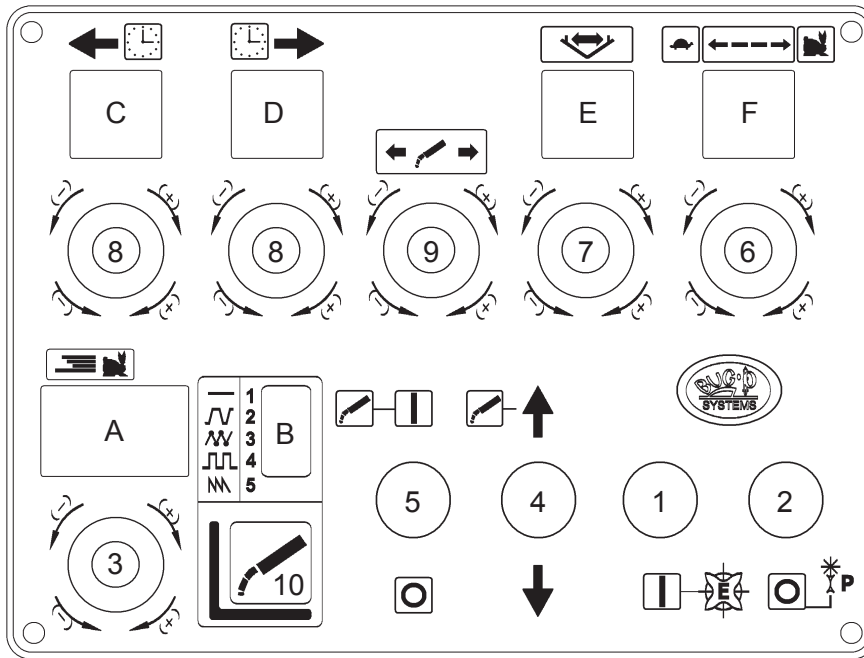

1. **Cycle Start Button** - Push button to initiate weld cycle. Weld contact will close if the Weld Switch is set to Auto and carriage will travel in the direction selected by the Travel Direction Switch.
2. **Cycle Stop Button** - Push button to stop welding cycle.
3. **Travel Speed Adjustment Knob** - Rotate knob to adjust carriage travel speed. Turning clockwise (right) will INCREASE speed.
4. **Travel Direction Switch** - Set switch to determine direction of carriage travel. Travel direction should be set *before* carriage travel is started.
5. **Weld Auto / Off Switch** - When switched to AUTO, weld contact will close with cycle start.
6. **Weave Speed Adjustment Knob** - Increase weaving speed by turning knob clockwise; decrease by turning counterclockwise.
7. **Weave Width Adjustment Knob** - Increase the weave width by turning the knob clockwise; decrease by turning counterclockwise.
8. **Dwell Time Adjustment** - Increase or decrease dwell time by turning the adjustment knob. The outer knob controls the left dwell; the inner knob controls the right dwell. The range for these settings is 0 - 9.9 sec.
9. **Steering Knob** - Turn knob clockwise to shift weave center to the right. Turning the knob counterclockwise will cause a shift to the left.
10. **Weave Select Button** - Use this button to select the weave type to be performed. Push the Weave Select Button (10) to select the desired weave number is displayed.

Displays - Digitally display real-time values during welding. Acceptable range, default value and units for each display are listed in the table, below. Also used when setting Parameters and enabling the remote.

Display	Description	Range	Default	Unit
A	Travel Speed	0 - 85.0 (0 - 33.5)	50.0	cm/min (in/min)
B	Weave Selector	1 - 5	5	
C	Left Dwell	0.0 - 9.9	3	sec
D	Right Dwell	0.0 - 9.9	3	sec
E	Weaving Width	0 - 99	30	%
F	Weaving Speed	0 - 99	30	%

USER INTERFACE - WIRELESS REMOTE CONTROL

The Digital Weaver includes a wireless remote that can be used to control the machine. Magnets in the back of the remote allow for easy storage on the machine. The remote has a range of 33 ft (10 m). Each remote communicates at a unique frequency, allowing multiple machines to operate in close proximity without interference.

The control functions of the remote differ from the control panel as follows:

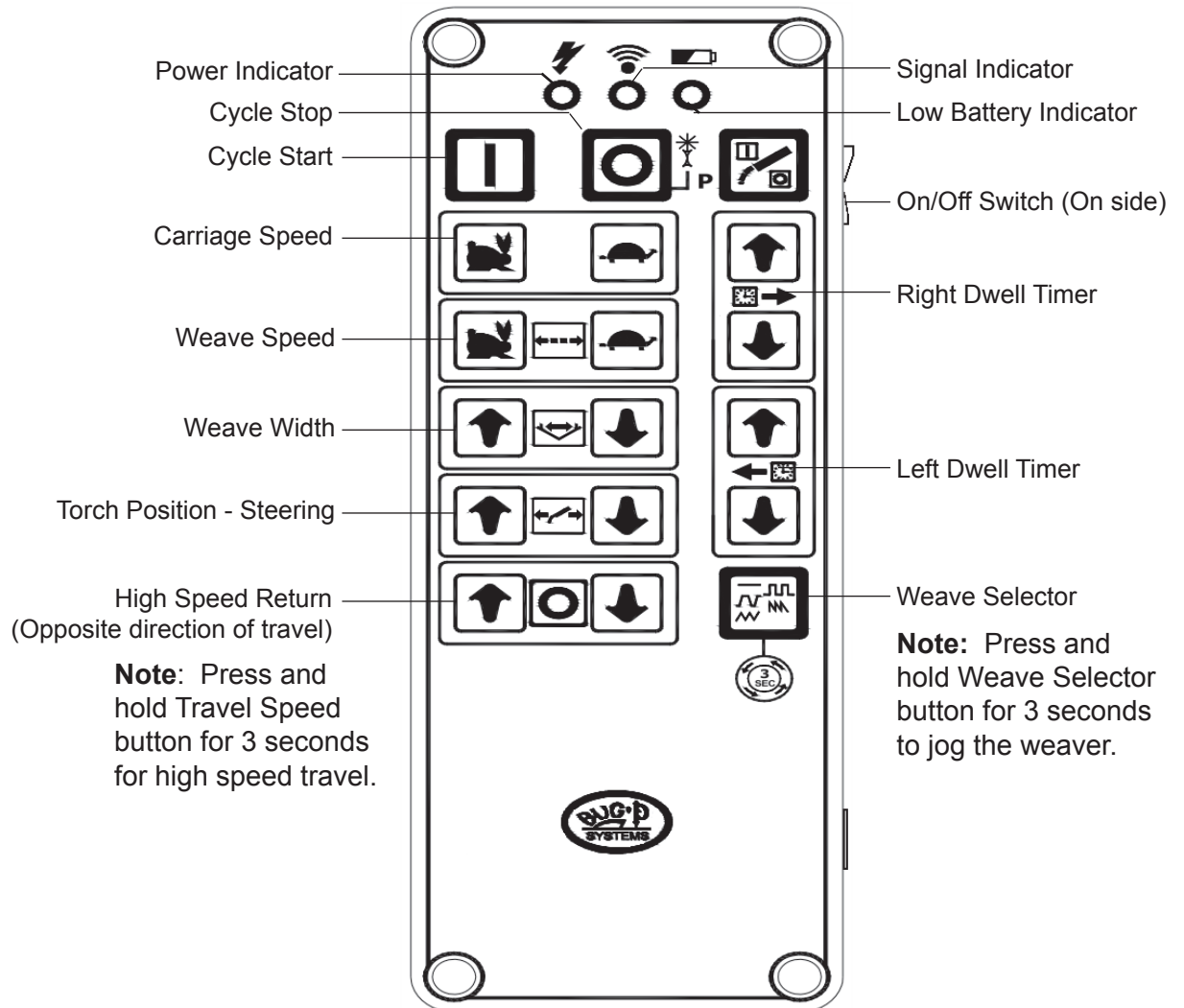

Figure 8: Remote Control Overview

ENABLING THE REMOTE CONTROL

The remote is factory enabled. However, following certain maintenance activities, such as replacing the battery or Main PCB, it will be necessary to enable the remote or establish communication between the remote and the machine.

1. While pressing the orange Stop button (on the machine control panel), connect the machine to power.
2. Release the orange Stop button.
3. While pressing the Stop button on the REMOTE, turn the remote ON. Continue to hold the Stop button for 3 - 5 seconds.
4. Release the Stop button on the REMOTE. The machine should reset and return to normal operating conditions.
5. Press the Start button on the REMOTE to confirm it was set.
6. If the machine DOES NOT START, repeat steps 1-5.

NOTE: Once communication has been established between a remote and a machine, that remote will only work with that machine. It cannot be used to control any other K-BUG device.

GLOBAL PARAMETERS

1. While holding down the Start button, plug the machine into an AC power source of appropriate voltage.
2. The active parameter will be displayed in the Left Dwell display. The current setting for the active parameter will be displayed in the Travel Speed display.
3. To adjust the active parameter, turn the Travel Speed Adjustment knob. Turning to the right, or clockwise, will increase the value; counterclockwise will decrease the value.
4. Press and release the Cycle Start button to scroll through the parameters.
5. When finished setting (all) values, press the Cycle Stop button and unplug the machine.

Display	Description	Range	Default	Unit
n.0	Puddle Build-up	0.0 - 9.9	1	sec
n.1	Crater Fill	0.0 - 9.9	1	sec
n.2	Weave speed with Center Return	0 - 99	99	sec
n.3	Maximum Weave Width	0 - 90	5	Degree
n.4	Center Move Width	--	360	Degree
n.5	Center Move Length	1 - 60	2	Pulse
n.6	Diff Value of travelling speed	1 - 20	10	
n.7	Signed data auto diff speed	1 - 7	7	
n.8	Motor emcy Auto Stop Time	0.0 - 9.9	3	sec
n.9	Travel Motor Reduce Ratio	20 - 200	40	
n.a	Weaving Motor Ratio	20 - 200	100	
n.b	Travel Wheel Diameter	0.0 - 99.9	22.5	mm
n.c	Demonstration Mode	On / Off	Off	
n.d	Operating Units	U1 / U2	U2	U1 (cm/min), U2 (in/min)
n.e.	Limit Switch Type	n.o / n.c.	n.o	n.o (normally open), n.c (normally closed)

CONVERTING UNITS

By default, the K-BUG 3000 will be factory set to operate in English units (in/min). If it is necessary to change units, follow the steps for checking Global Parameters, above. Use the Cycle Start button until "5" is shown on the Display. Turn the Travel Speed Adjustment knob right or left to select the desired Units. Choose "U1" for Metric (cm/min) or "U2" for English (in/min).

INSTALLATION AND OPERATION

Cable Connections

- Clamp torch into the Torch Clamp Assembly
- Connect Weld Contactor lead from machine to contact circuit of feeder
- Connect power input cable to proper electric source
- Make all connections between power source and wire feeder
 - CAUTION:** Carefully route power cable as it may become entangled during operation, resulting in damage to people or equipment.
- Set the Carriage so the torch is at the weld starting point
- Adjust the target angle and position of the Torch, as needed
- Set welding parameters as needed - Weave Width, Dwell times, Weave type
- Verify adequate Shielding Gas Supply
- Set weld enable switch to ON
- Start Welding - Toggle Welding Switch to AUTO, verify desired travel direction is set and travel speed is > 0 in/min and press Cycle Start Button
- Press Cycle Stop Button when welding is complete

CABLE INTERCONNECT DIAGRAM

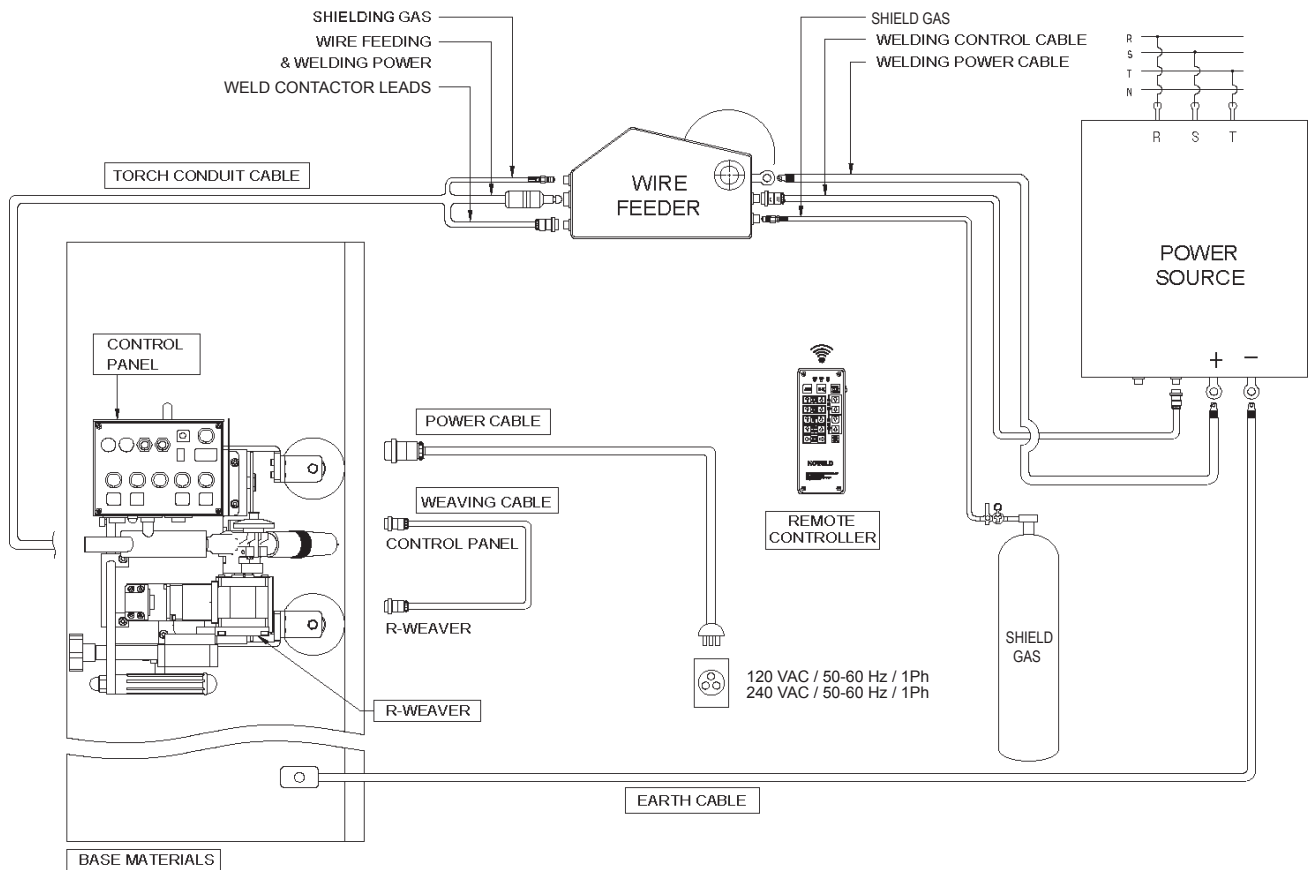

MAINTENANCE

The Bug-O K-BUG 3000 carriage should be periodically checked and cleaned to maximize service life.

Before use:

Check all screws in the torch clamp and guide rollers. Tighten as needed. Loose fasteners may cause uneven travel or inconsistent weld quality.

During use:

Monitor wheels, motor and welding torch for abnormal noise or overheating.

After each use:

1. Clean control panel to remove dust and other debris.
2. Inspect carriage base, wheels, guide rollers, slide adjustment, magnets and torch for weld spatter or other debris. Clean as needed.
3. Inspect power cable and torch cable for cracked, cut or damaged insulation. Replace as needed.
4. Inspect connectors for damaged pins or loose connections. Replace as needed.

TROUBLESHOOTING

Symptom	Cause	Repair
Control panel Display is not LIT	Disconnected Control Cable	Verify control cable is properly connected to machine
	Faulty Control Cable	Replace Cable
	Control Box Fuse Tripped or Disconnected	Replace fuse. If problem persists, contact service rep.
No Arc when Welding Auto/Off Switch turned to AUTO (and Cycle Start is pressed)	Weld Auto/Off Switch set to OFF	Turn Weld Auto/Off Switch to AUTO
	Loose contact of Welding Leads	Check ground connections. Verify good contact on clean, unpainted surface.
	Bad or incorrectly wired Welding Auto/Off Switch	Check Wiring. Replace Switch, if needed
	Stop Sensor Engaged	Disengage Stop Sensor
Carriage does not travel when Cycle Start Button is pushed	Failed drive component	Check Motor, Drive Chain and Gearbox. Replace as needed
	Faulty or incorrectly wired Cycle Start Button	Check Wiring. Replace button, if needed.
	Faulty MAIN PCB	Replace MAIN PCB
	Stop Sensor Engaged	Disengage Stop Sensor
	Global Parameters are not set correctly	Ensure the global parameter for the limit switch (n.e, shown in GLOBAL PARAMETERS table on Page 10) is set for the correct limit switch configuration: n.o for normally open switches or n.c for normally closed
Torch targets wrong position	Loose fastener on Torch Clamp	Check and tighten screws, replace if needed.
Slide is hard to adjust	Dust or other debris on slide parts	Clean slide parts. Lubricate with light oil
Carriage stops during automatic welding	Stop sensor engaged	Disengage Stop Sensor
	Power Cable disconnected	Reroute and reconnect Power Cable
Arc continues after Welding Auto/Off Switch is set to OFF	The Welding Auto/Off Switch is still set to Auto	Turn Weld Auto/Off Switch to OFF
	Faulty or incorrectly wired Welding Auto/Off Switch	Check Wiring. Replace Switch, if needed.

TROUBLESHOOTING, CONT'D.

K-BUG ERROR LIST

NO.	SYMPTOM	CAUSE	SOLUTION
E-03	Motion Stop	Main PCB EET ROM Error	Main PCB Replacement
E-05	Travelling Stop	Auto-Stop Travelling Motor may be overloaded / shorted	Push and release Stop Button IF UNRESOLVED: 1. Check for loose wiring connection at drive motor and weave motor if equipped (see below). 2. Replace motor or motor reducer 3. Replace main PCB

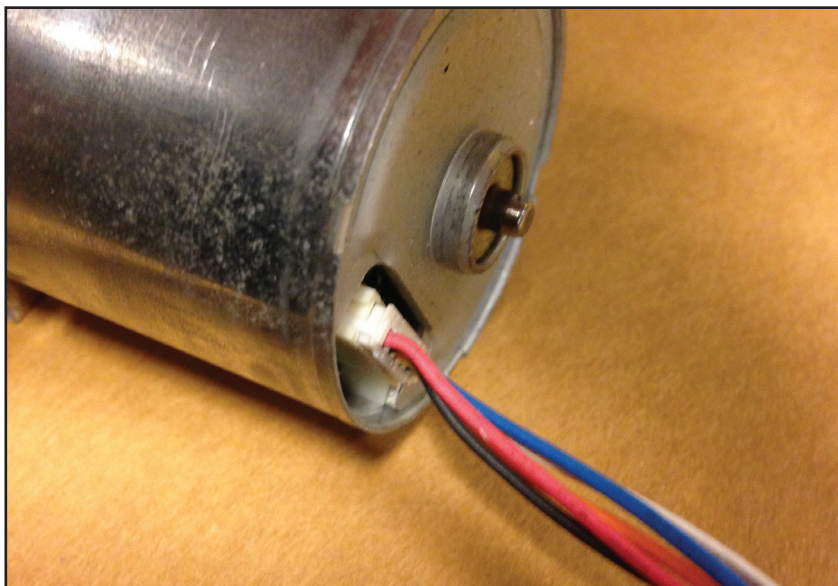
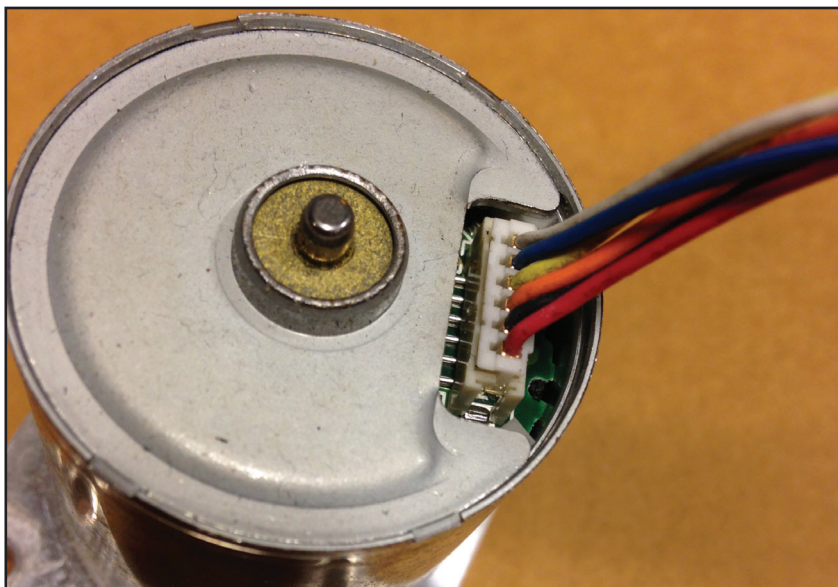

K-BUG 3000 ASSEMBLY VIEW

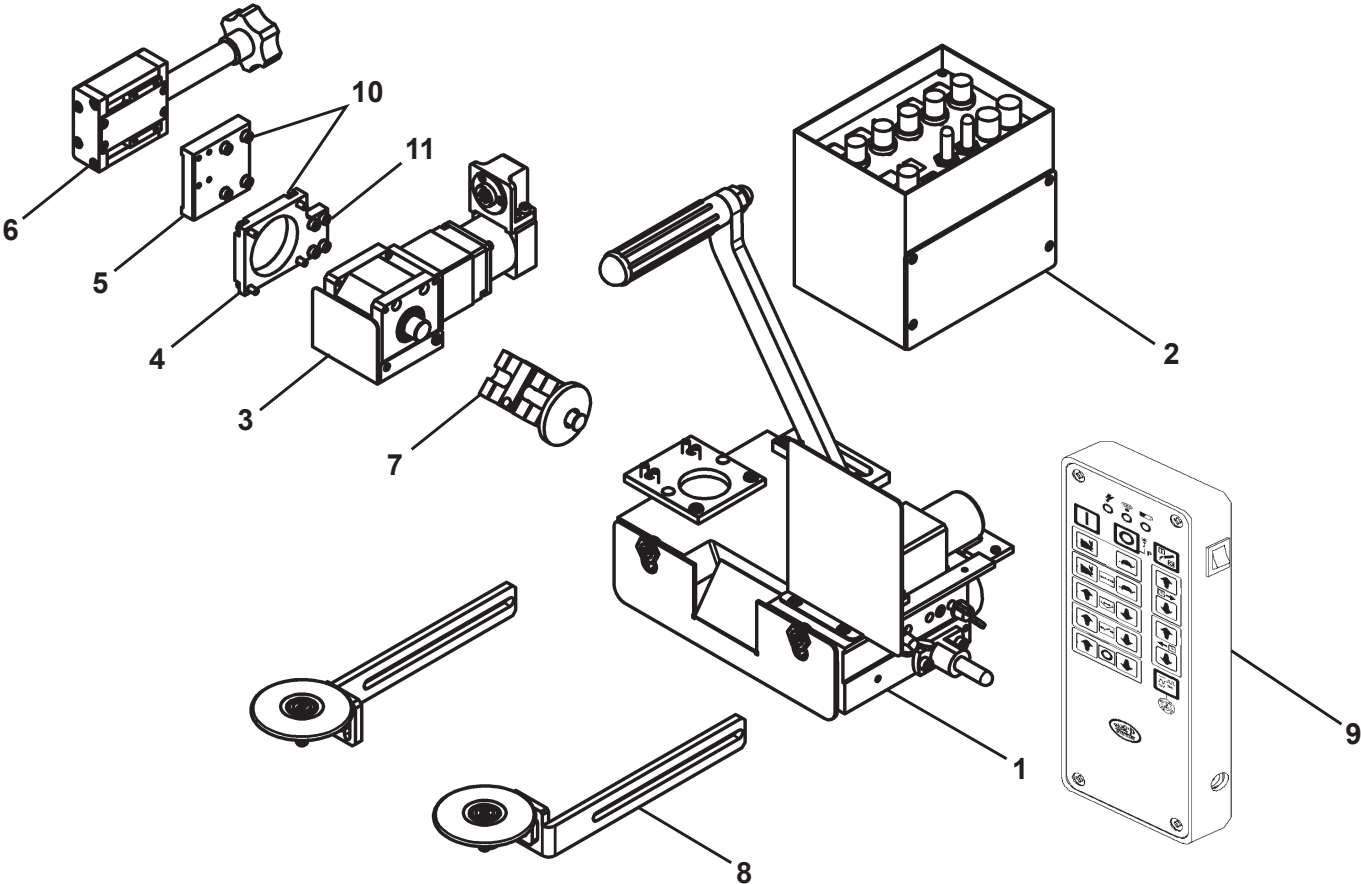

K-BUG 3000 ASSEMBLY VIEW / PARTS LIST

<u>ITEM</u>	<u>QTY</u>	<u>PART NO.</u>	<u>DESCRIPTION</u>
1	1	KBUG-3010	Carriage Assembly
2	1	KBUG-3060	Control Tower Assembly
3	1	KBUG-3070	Weaver Assembly
4	1	KBUG-3078	Weaving Fixed Bracket
5	1	KBUG-3077	Slide Fixed Plate
6	1	KBUG-3080	Y-Slide Assembly
7	1	KBUG-3120	Torch Clamp Assembly
8	1	KBUG-3130	Guide Arms Assembly
9	1	KBUG-3100	Wireless Remote Controller
10	4	MET-0577-SS	Soc Hd Cap Scr M4 x 16
11	4	MET-0553-SS	Soc Hd Cap Scr M4 x 10
*	1	KBUG-2274-15**	Power Cable, 120 VAC, 15' (4.5 m)
*	1	KBUG-3079	Weaving Cable Assembly
*	1	KBUG-3092**	Charging Unit 120 VAC / 50-60 Hz / 1 Ph

* Not Shown

** Note: For K-BUG 3002 (240 VAC model), Power Cable is KBUG-2272-15 and the Remote Charger is KBUG-3093.

K-BUG 3000 WIRING DIAGRAM

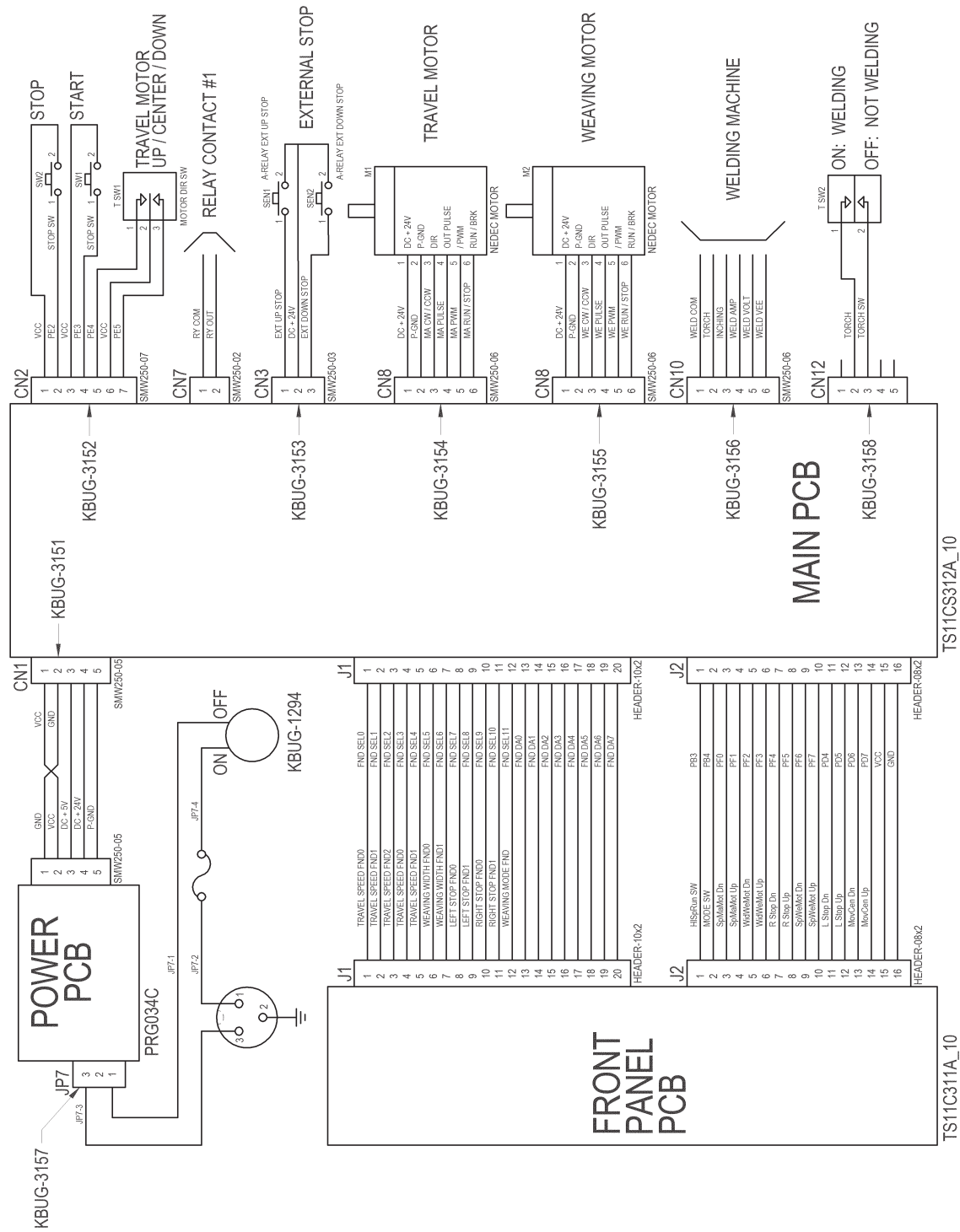

KBUG-3060 CONTROL TOWER ASSEMBLY / EXPLODED VIEW / PARTS LIST

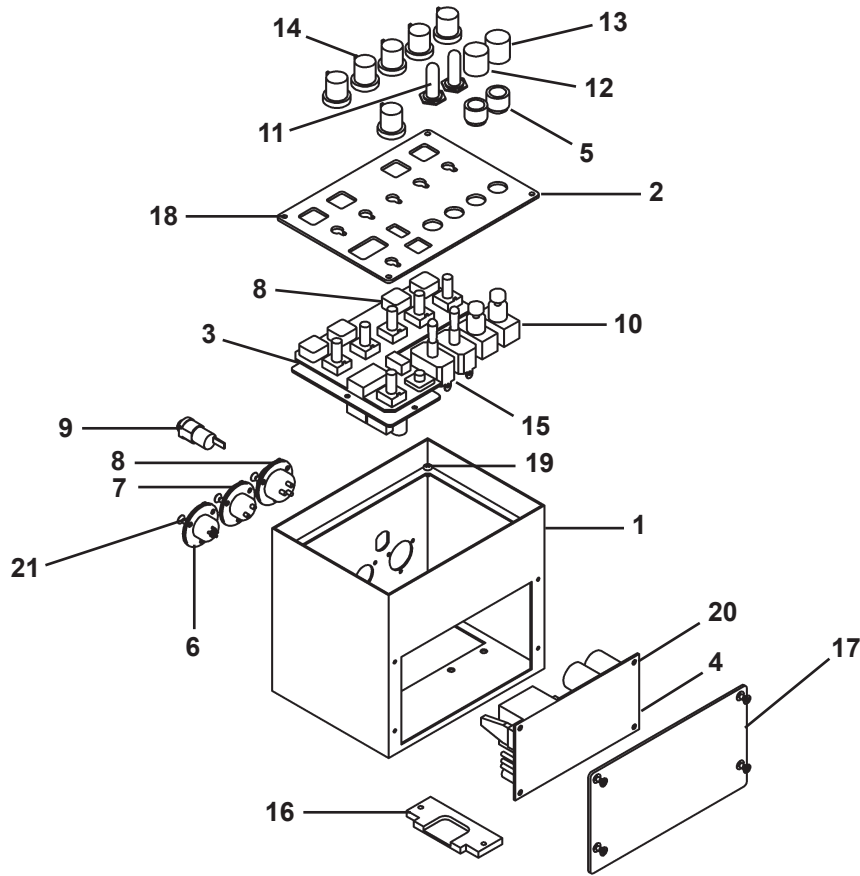

<u>ITEM</u>	<u>QTY</u>	<u>PART NO.</u>	<u>DESCRIPTION</u>
1	1	KBUG-3061	Panel
2	1	KBUG-3062	Legend Plate
3	1	KBUG-3063	Main PCB
4	1	KBUG-3064	Power PCB
5	2	KBUG-1124	Push Button Covers
6	2	KBUG-3116	Weaving Connector
7	1	KBUG-1133	Torch Connector
8	2	KBUG-1132	Power Connector
9	1	KBUG-1131	Fuse
10	2	KBUG-3112	Push Button
11	2	KBUG-1122	Toggle Switch Cover
12	1	KBUG-1128	Push Button Cover, Black
13	1	KBUG-1127	Push Button Cover, Orange
14	6	KBUG-1129	Volume Knob
15	2	KBUG-3114	Toggle Switch
16	1	KBUG-3166	Panel Bracket
17	1	KBUG-3068	Panel Plate
18	4	MET-0143-SS	Pan Hd Phil Scr M3 x 10
19	6	MET-0053	Pan Hd Phil Scr M4 x .7 x 10
20	4	MET-0141-SS	Pan Hd Phil Scr M3 x 6
21	9	MET-0943	Flt Hd Soc M3 x 10

KBUG-3010 CARRIAGE ASSEMBLY / EXPLODED VIEW

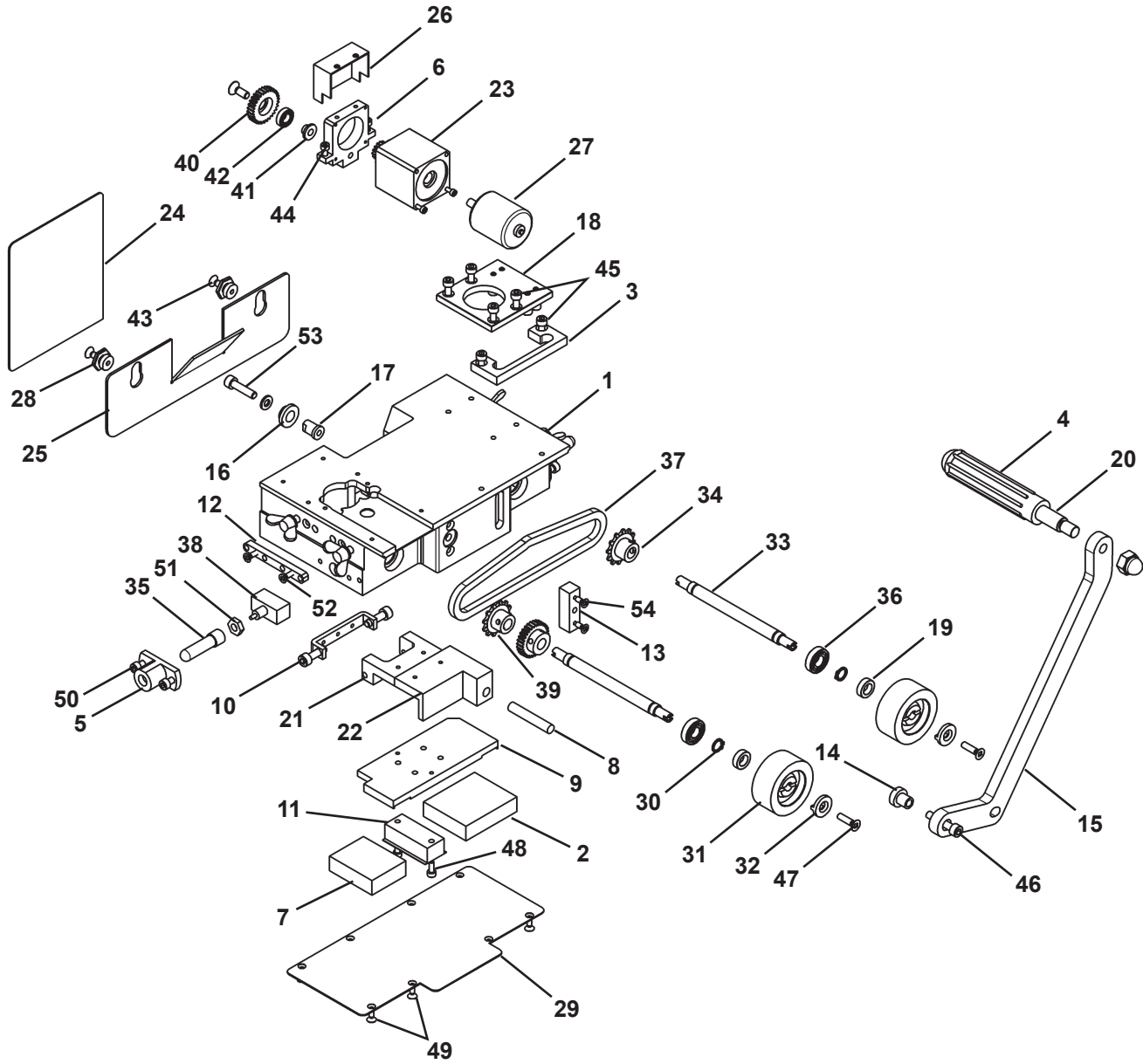

KBUG-3010 CARRIAGE ASSEMBLY / PARTS LIST

<u>ITEM</u>	<u>QTY</u>	<u>PART NO.</u>	<u>DESCRIPTION</u>
1	1	KBUG-3011	Body
2	1	KBUG-3012	Magnet
3	1	KBUG-3013	Lever Cover
4	1	KBUG-3014	Grip Cover
5	2	KBUG-3015	Sensor Cover
6	1	KBUG-3016	Motor Joint Case
7	1	KBUG-3017	Small Magnet
8	1	KBUG-3018	Lever Shaft
9	1	KBUG-3019	Magnet Plate
10	1	KBUG-3021	Lever Housing Plate
11	1	KBUG-3056	Magnet Bracket
12	2	KBUG-3022	Guide Plate
13	1	KBUG-3023	Lever Plate
14	1	KBUG-3024	Lever Bushing
15	1	KBUG-3025	Grip Bracket
16	1	KBUG-3026	Tension Bushing
17	1	KBUG-3027	Tension Shaft
18	1	KBUG-3028	Slide Fixed Bracket
*19	4	KBUG-3029	Shaft Bushing
20	1	KBUG-3031	Grip
21	1	KBUG-3032	Lever Housing-1
22	1	KBUG-3033	Lever Housing-2
23	1	KBUG-3034	Gear Head
24	1	KBUG-3035	Panel Cover
25	1	KBUG-3036	Spatter Cover
26	1	KBUG-3037	Motor Cover
27	1	KBUG-3038	DC Brushless Motor
28	2	KBUG-3039	Spatter Cover Bolt
29	1	KBUG-3041	Bottom Cover
30	4	KBUG-3042	Snap Ring
31	4	KBUG-1036	Wheel
*32	4	KBUG-3044	Wheel Cover
*33	2	KBUG-3045	Wheel Shaft
34	2	KBUG-3046	Chain Sprocket
35	2	KBUG-3047	Sensor Bushing
36	4	KBUG-3048	Shaft Bearing
37	1	KBUG-3049	Chain
38	2	KBUG-3051	Stop Sensor
39	1	KBUG-3052	Shaft Gear
40	1	KBUG-3053	Center Gear
41	1	KBUG-3054	Gear Bushing
42	1	KBUG-3055	Gear Bearing
43	2	N60799-105-14-02	Flt Hd Scr M5 x 15
44	2	MET-0577-SS	Soc Hd Cap Scr M4 x 13
45	6	N18230-205-10-00	Soc Hd Cap Scr M5 x 10
46	1	MET-0570	Soc Hd Cap Scr M6 x 30
47	4	N60799-105-12-02	Flt Hd Soc Scr M5 x 12
48	2	MET-0553-SS	Soc Hd Cap Scr M4 x 10
49	8	N60091-204-50-00	Flt Hd Scr M4 x 5
50	2	N18230-205-30-00	Soc Hd Cap Scr M5 x 30
51	2	MET-1370-SS	M6 Hex Nut
52	2	MET-0953-SS	Flt Hd Soc Scr M4 x 8
53	1	N18230-206-14-00	Soc Hd Cap Scr M6 x 14
54	2	MET-0953-SS	Flt Hd Soc Scr M4 x 9

*If replacement parts are required, refer to Addendum on page 24.

KBUG-3070 WEAVING ASSEMBLY / EXPLODED VIEW / PARTS LIST

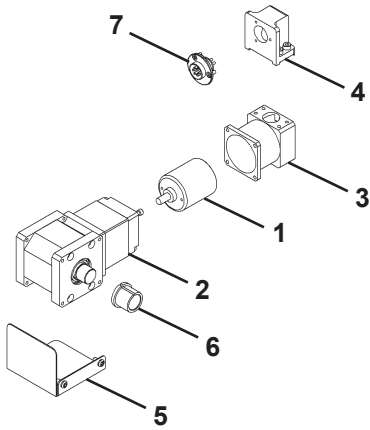

<u>ITEM</u>	<u>QTY</u>	<u>PART NO.</u>	<u>DESCRIPTION</u>
1	1	KBUG-3071	DC Brushless Motor
2	1	KBUG-3072	R/W Geared Motor
3	1	KBUG-3073	Motor Case
4	1	KBUG-3074	Connector BRK
5	1	KBUG-3075	Weaving Spatter Cover
6	1	KBUG-3076	Bushing
7	1	KBUG-3116	Weaving Connector

KBUG-3080 Y-SLIDE ASSEMBLY / EXPLODED VIEW / PARTS LIST

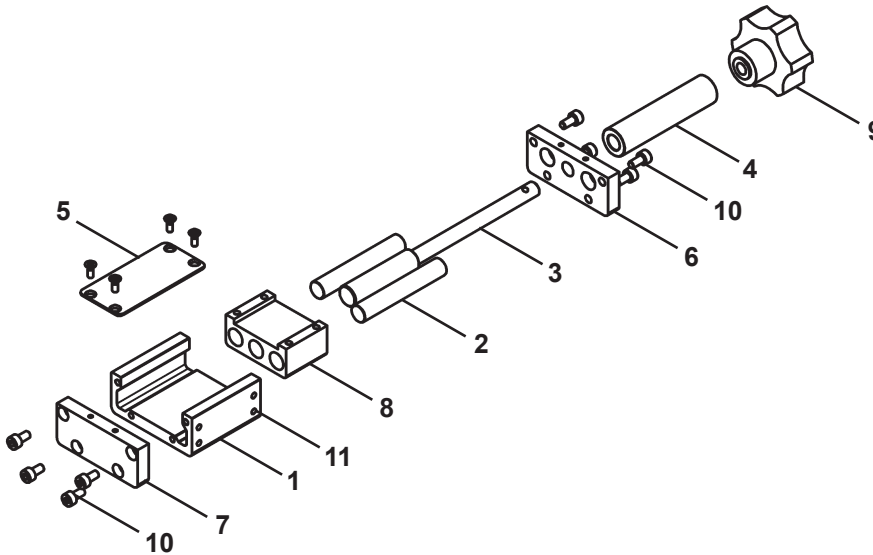

<u>ITEM</u>	<u>QTY</u>	<u>PART NO.</u>	<u>DESCRIPTION</u>
1	1	KBUG-3081	Horizontal Slide Housing
2	2	KBUG-3082	Slide Bar
3	1	KBUG-3083	Slide Bolt
4	1	KBUG-3084	Slide Bolt Cover
5	1	KBUG-3085	Slide Cover
6	1	KBUG-3086	Slide Unit Bracket (U)
7	1	KBUG-3087	Slide Unit Bracket (D)
8	1	KBUG-3089	Slide Block (L)
9	1	KBUG-3091	Knob
10	8	MET-0553-SS	Soc Hd Cap Scr M4 x 10
11	4	MET-0552-SS	Soc Hd Cap Scr M4 x 8

KBUG-3100 REMOTE CONTROL / EXPLODED VIEW / PARTS LIST

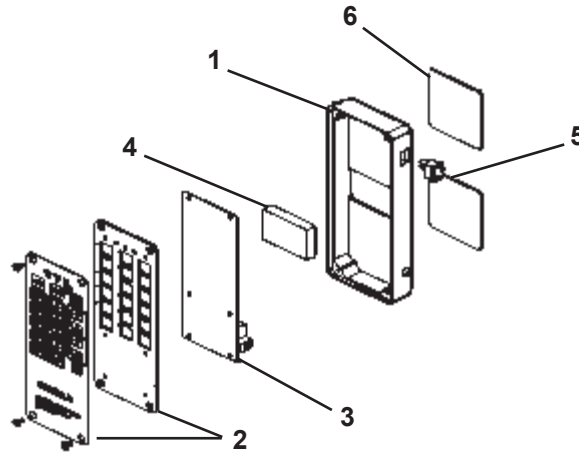

<u>ITEM</u>	<u>QTY</u>	<u>PART NO.</u>	<u>DESCRIPTION</u>
1	1	KBUG-3101	Panel Case
2	1	KBUG-3102	Remote Name Panel & Legend Sticker
3	1	KBUG-3103	Main PCB
4	1	KBUG-3104	Battery
5	1	KBUG-3105	Switch
6	2	KBUG-3106	Rubber Magnet
*	1	KBUG-3092**	Charging Unit 120 VAC

* Not Shown

** Note: For K-BUG 3002 (240 VAC model) the Remote Charger is KBUG-3093.

KBUG-3120 TORCH CLAMP ASSEMBLY / EXPLODED VIEW / PARTS LIST

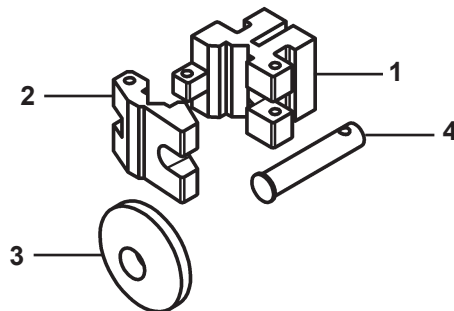

<u>ITEM</u>	<u>QTY</u>	<u>PART NO.</u>	<u>DESCRIPTION</u>
1	1	KBUG-3121	Torch Clamp (L)
2	1	KBUG-1111	Torch Clamp (U)
3	1	KBUG-1113	Clamp Fixed Knob
4	1	KBUG-1112	Clamp Fixed Bolt

KBUG-3130 GUIDE ROLLER ASSEMBLY / EXPLODED VIEW / PARTS LIST

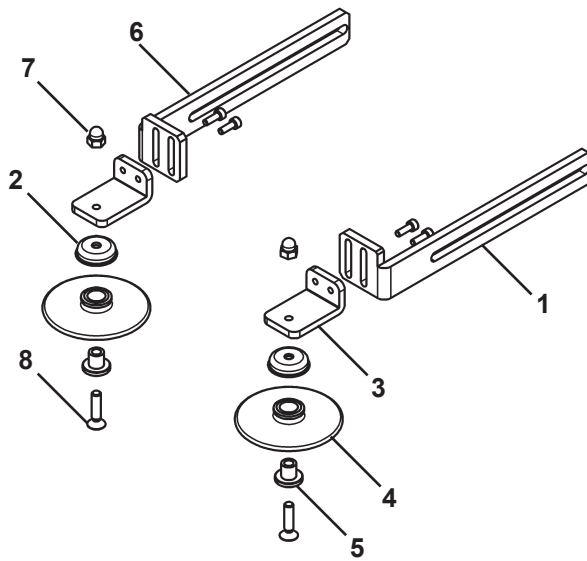

<u>ITEM</u>	<u>QTY</u>	<u>PART NO.</u>	<u>DESCRIPTION</u>
1	1	KBUG-3131	Guide Arm (L)
2	2	KBUG-1063	Guide Roller Cover
3	2	KBUG-3132	Guide Roller Bracket
4	2	KBUG-3162	Guide Roller
5	2	KBUG-1061	Guide Roller Bushing
6	1	KBUG-3133	Guide Arm (R)
7	2	100-0378	Acorn Nut M6-1.0
8	2	100-0383	Flt Hd Phil Scr M6-1.0 x 25mm

SBG-450- - GUN & CABLE ASSEMBLY / EXPLODED VIEW / PARTS LIST

Whip Length: 15 (15 ft / 4.6 m) or 25 (25 ft / 7.6 m)
 Wire Size: 035, 040, 045, 052, 116, 564
 Connector Type: E (Euro), L (Lincoln 3/4"), M (Miller), T (Lincoln, small)

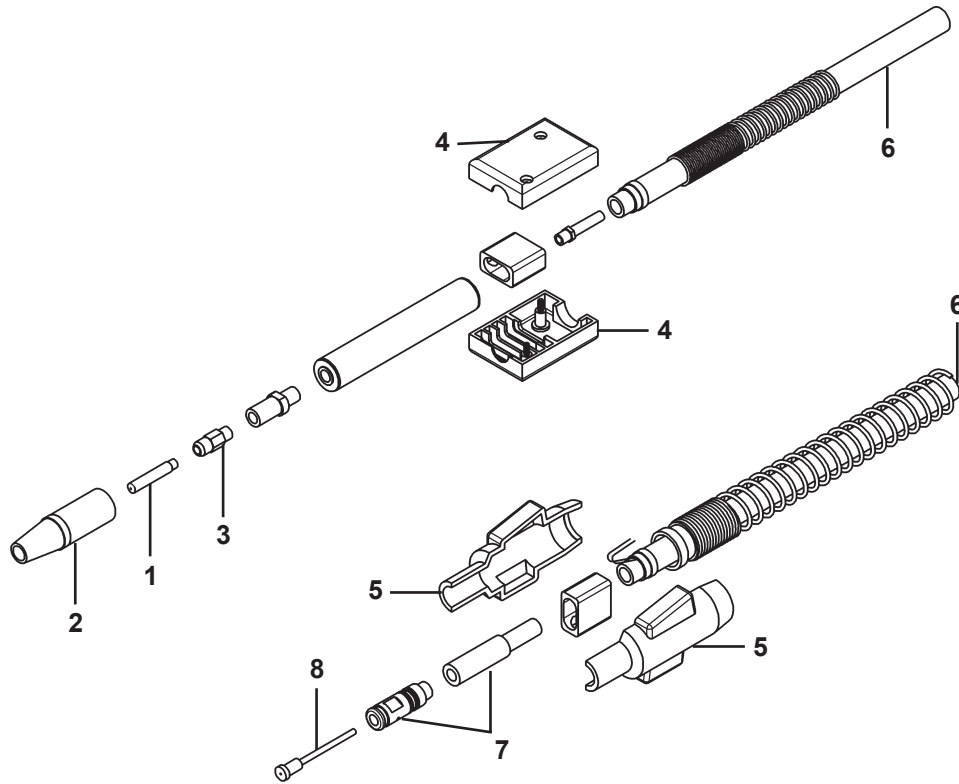

PARTS LIST				WIRE SIZE					
ITEM	QTY	PART NO.	DESCRIPTION	.035 (.9 mm)	.040 (1.0)	.045 (1.2)	.052 (1.4)	1/16 (1.6)	5/64 (2.0)
1	1	BUG-3159-35	16S-35 (.9 mm) Contact Tip	X					
1	1	BUG-3159-45	16S-45 (1.2 mm) Contact Tip			X			
1	1	BUG-3159-52	16S-52 (1.4 mm) Contact Tip				X		
1	1	BUG-3159-116	16S-116 (1.6 mm) Contact Tip					X	
1	1	BUG-3159-564	16S-564 (2.0 mm) Contact Tip						X
1	1	PWS-4436-1.0	16S-40 (1.0 mm) Contact Tip		X				
2	1	PWS-4447	27S62 H.D. Nozzle 5/8"	X	X	X	X	X	X
3	1	PWS-4449	PX57HD Gas Diffuser	X	X	X	X	X	X
4	1	CWO-8017	Case w/ Binder Screws (Front)	X	X	X	X	X	X
5	1	PWS-4411	Case w/ Binder Screws (Back)	X	X	X	X	X	X
6	1	STW-3044	450 Amp Cable	X	X	X	X	X	X
7	1	R174-T	Connector, Small Lincoln						
7	1	R174-L	Connector, 3/4" Lincoln						
7	1	R174-M	Connector, Miller						
7	1	R174-X	Connector, Euro						
8	1	CWO-8009	44-3545-15 Cable Liner	X	X	X			
8	1	CWO-8011	44-116-15 Cable Liner				X	X	
8	1	CWO-8012	44-564-15 Cable Liner						X
**	1	SBG-1004	Gas Hose Assembly	X	X	X	X	X	X
**	2	SBG-1005	Gas Hose Clamps	X	X	X	X	X	X

** Not shown. Required only with standard Lincoln guns (SBG-450-L).

KBUG-3500, K3000 W/BUG-O RACK & REMOTE / EXPLODED VIEW / PARTS LIST

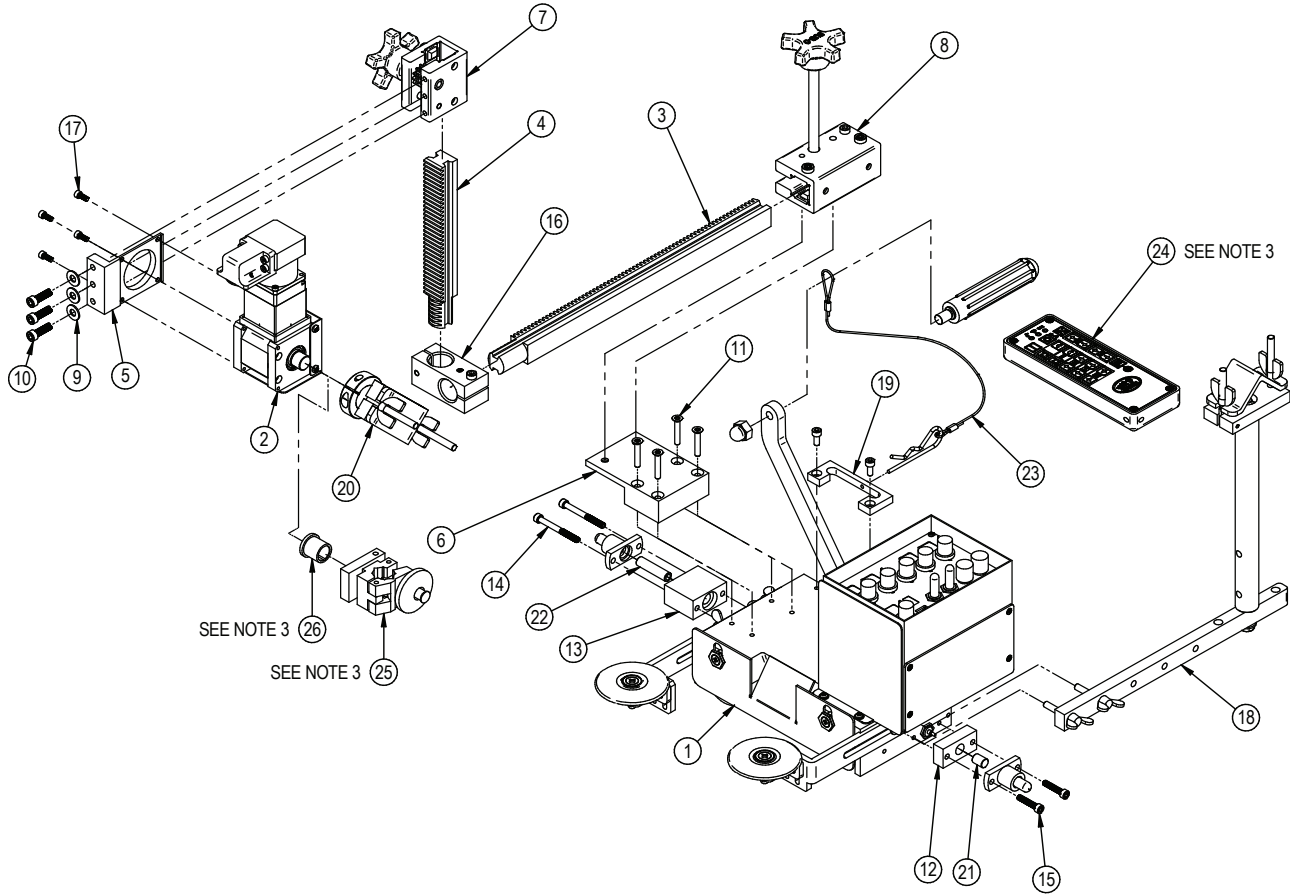

ITEM	PART #	DESCRIPTION	QTY
1	KBUG-3000-COM	KBUG-3000 COMMON ASSY 120V	1
2	KBUG-3070	R-WEAVING ASSEMBLY	1
3	BUG-1796	MACHINED RACK 14"	1
4	BUG-1853	MACHINED RACK 7-1/2"	1
5	KBUG-3004-NN	WEAVER BRACKET	1
6	100-0964	RACKING GROUP MOUNTING PLATE	1
7	KBUG-3010-NN	RACKRIDER	1
8	KBUG-3007-NN	3.5" RACKHOLDER	1
9	WAS-0240	1/4 SAE FLAT	3
10	MET-0579-SS	SOC HEAD CAP SCREW M6 X 20	3
11	100-0965	FLT HD SOC SCR M5 X 0.80 X 30MM	4
12	KBUG-3012-NN	LIMIT SWITCH MOUNT BLOCK, 1/2"	1
13	KBUG-3013-NN	LIMIT SWITCH MOUNT BLOCK, 1.5"	1
14	MET-2567	SOC HD CAP SCR M5 X 50	2
15	MET-2562-SS	SOC HD CAP SCR M5 x 25	2
16	BUG-5462	RIGHT ANGLE CLAMP	1
17	MET-0553-SS	SOC HD CAP SCR M4 x 10	4
18	KBUG-1290	CABLE ANCHOR ASSEMBLY	1
19	100-0731	LEVER COVER WITH PIN HOLE	1
20	100-0953	CLAMP ASSEMBLY	1
21	100-0956	LIMIT SWITCH PLUNGER EXT, SHORT	1
22	100-0957	LIMIT SWITCH PLUNGER EXT, LONG	1
23	100-0961	HAIR PIN AND LANYARD ASSEMBLY	1
24	KBUG-3100	REMOTE CONTROL ASSEMBLY	1
25	KBUG-3120	TORCH CLAMP ASSEMBLY	1
26	KBUG-3076	BUSHING	1

NOTES:

1. THREAD LOCK MOUNTING FASTENERS TO TRACTOR.
2. CABLES AND CABLE ASSEMBLIES NOT SHOWN.
3. BAG ITEMS 24, 25 & 26 WITH THE ASSEMBLY.

ACCESSORIES

KBUG-1067 Magwheel Add-On Kit

Magnetic guide wheels available for curved or irregular seams.

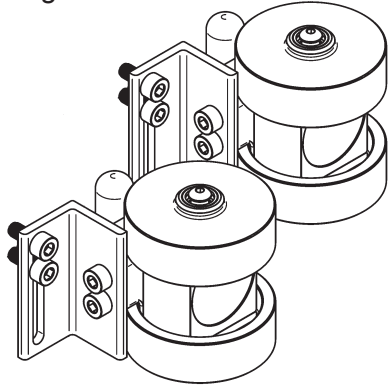

KBUG-3005-BW Butt Weld Kit

Adjustable slide arm positions torch farther from the carriage body, allowing the User greater flexibility welding fillet or butt joints. Second slide allows fine-tune height adjustment of torch.

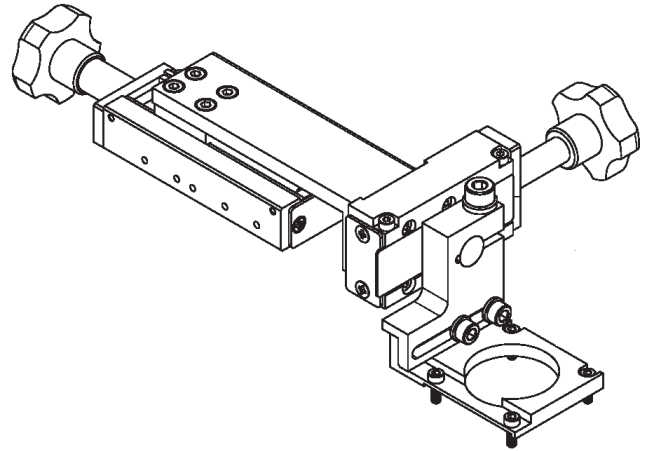

KBUG-1290 Cable Anchor

The cable anchor acts as a strain relief to keep the supply cable from dragging the torch out of position.

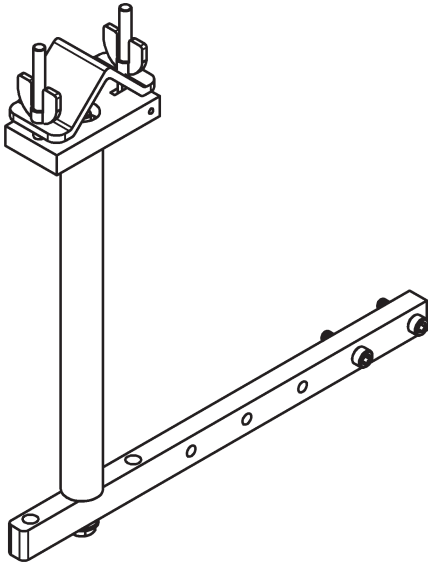

KBUG-1170 Long Arm Assembly

Convenient torch holder assembly to relocate torch away from the machine to reduce heat affects. This can be used for welding applications other than downhand.

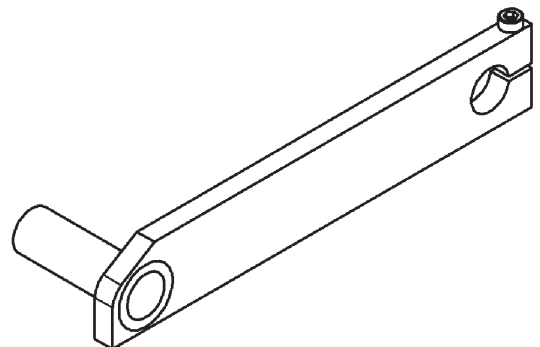

ACCESSORIES

100-0902 KBUG Guide Rail Assembly (6' long)

This includes a complete rail assembly, but does not include hardware that needs to be installed on our machines.

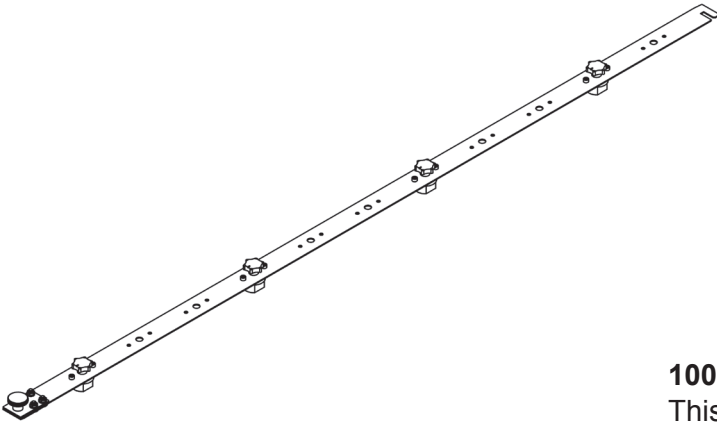

100-0910-3000 KBUG Arm Guide Kit

This includes all hardware needed to be mounted to KBUG-3000.

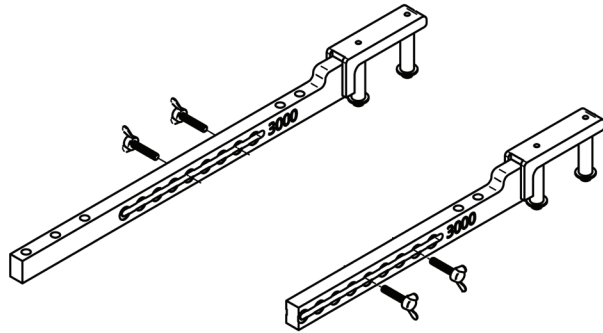

100-1002 KBUG-3000 to KBUG-3500 CONVERSION KIT

To convert a KBUG-3000 or KBUG-3000-BAT to a KBUG-3500 or KBUG-3500-BAT

INSTALLATION OF GUIDE RAIL

In order to install the Guide Rail, you must have either a KBUG-3500 or 100-0910-3000 kit.

The Guide Rail is very simple to install. It is only necessary to place the guide rail parallel to the weld joint and turn on the magnets by rotating the knob on the top of each magnet. Typically the Guide Rail is placed 3 to 4 inches from the weld joint but this is dependent upon the local surroundings for the application and should be adjusted by the user as needed. It is possible to add additional magnets to the guide rail if the particular application warrants such as a smaller surface diameter. The recommended minimum diameters for the Guide Rail with the KBUG-3500 are 55 inches for exterior travel and 100 inches for interior travel.

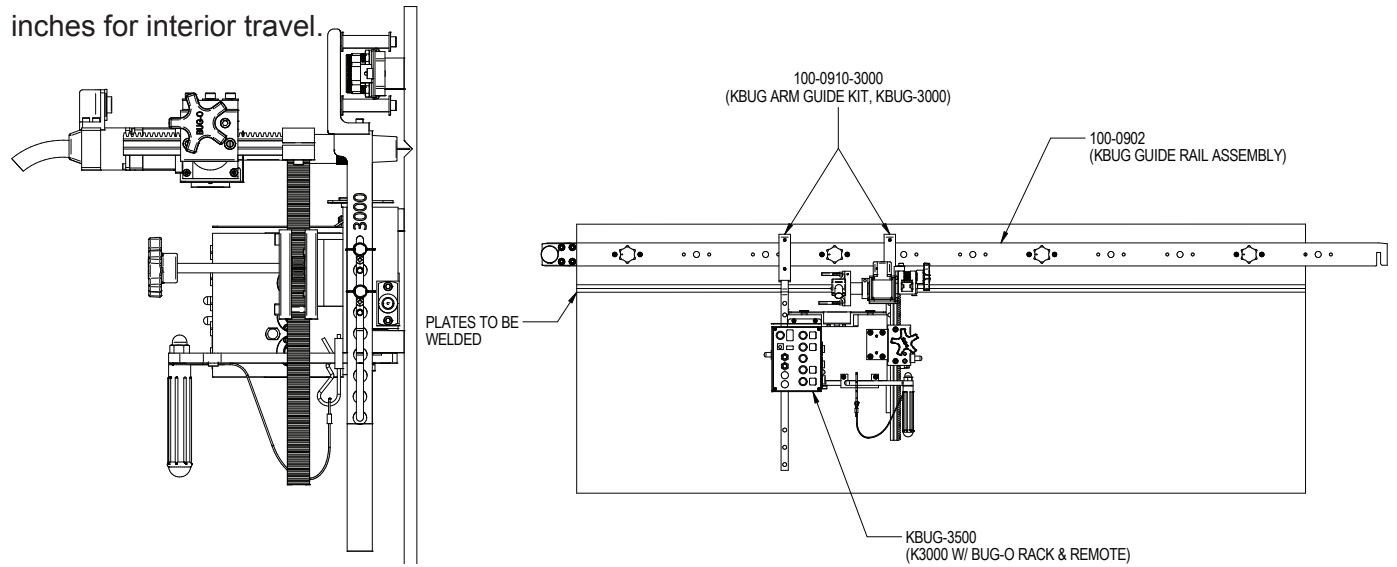

100-0902 KBUG GUIDE RAIL ASSEMBLY / EXPLODED VIEW / PARTS LIST

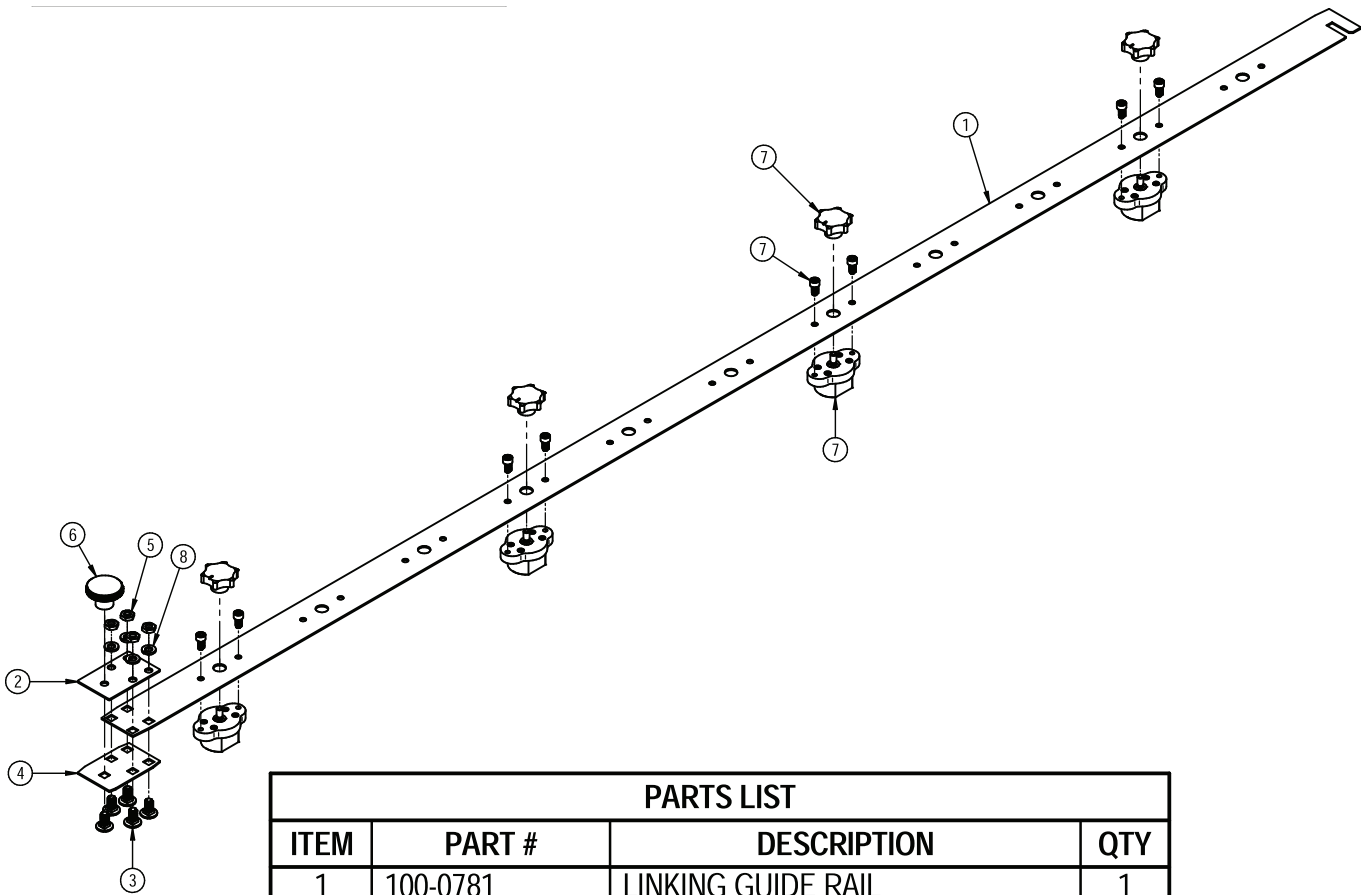

PARTS LIST			
ITEM	PART #	DESCRIPTION	QTY
1	100-0781	LINKING GUIDE RAIL	1
2	100-0787	JOINT TAB	1
3	100-0780	CARRIAGE BOLT M8-1.25 X 16MM	5
4	100-0779	END TAB	1
5	MET-1380-SS	M8 HEX NUT	4
6	100-0792	KNURLED GRIP KNOB M8-1.25	1
7	100-0903	ON/OFF MAGNET ASSEMBLY	4
8	WAS-0251	5/16" SPLIT LOCK WASHER	4

100-0910-3000 KBUG ARM GUIDE KIT

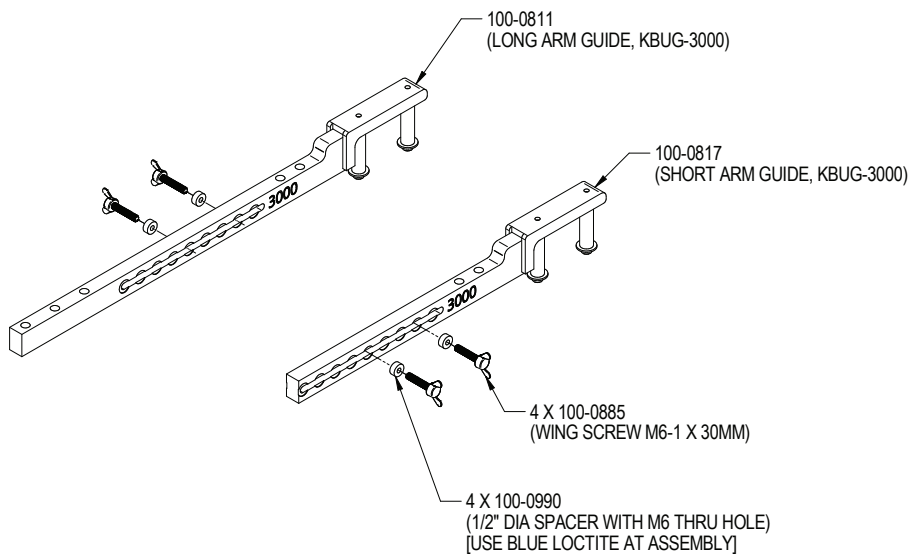

100-0811 LONG ARM GUIDE ASSEMBLY / EXPLODED VIEW / PARTS LIST

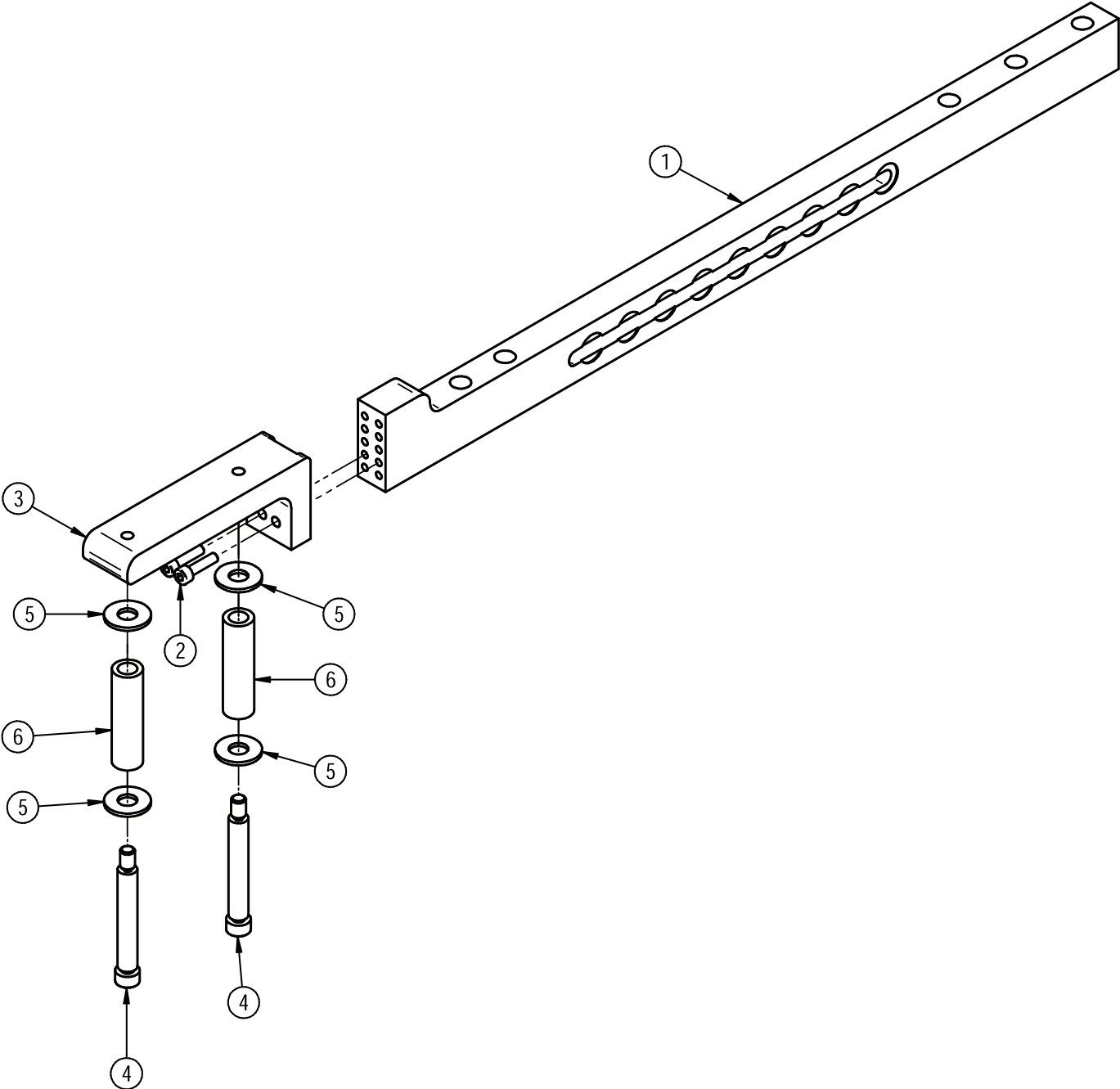

PARTS LIST			
ITEM	PART #	DESCRIPTION	QTY
1	100-0813	LONG ARM, KBUG-3000	1
2	MET-0577-SS	SOC HD CAP SCR M4 X 16	2
3	100-0819	SLIDE	1
4	100-0907	SOC HD SHOULDER BOLT, M6 X 1.0, 8MM SHLD DIA	2
5	WAS-0255	OIL IMPREG. BRONZE THRUST WASH	4
6	100-0820	LONG FOLLOWER SLEEVE WHEEL	2

100-0817 SHORT ARM GUIDE ASSEMBLY / EXPLODED VIEW / PARTS LIST

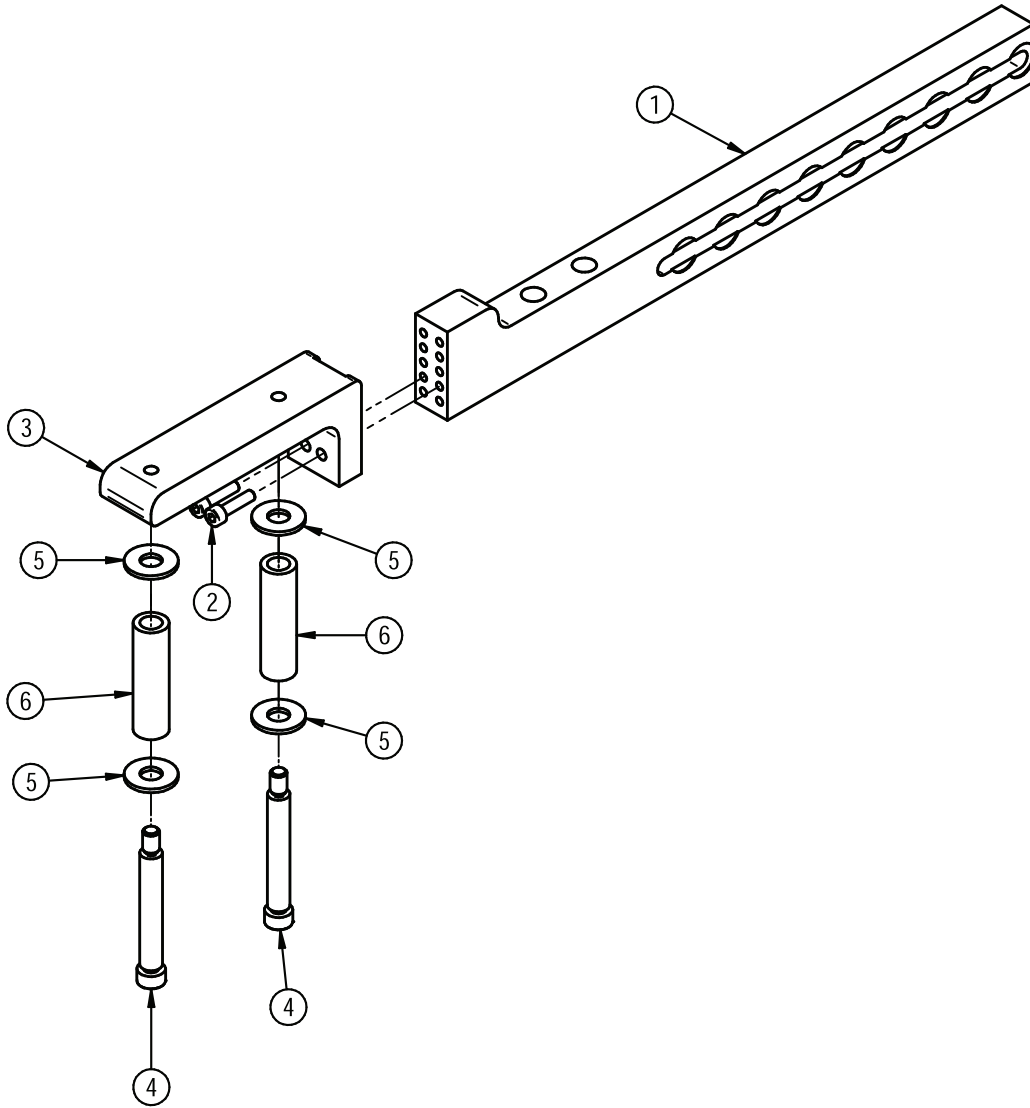

PARTS LIST			
ITEM	PART #	DESCRIPTION	QTY
1	100-0815	SHORT ARM, KBUG-3000	1
2	MET-0577-SS	SOC HD CAP SCR M4 X 16	2
3	100-0819	SLIDE	1
4	100-0907	SOC HD SHOULDER BOLT, M6 X 1.0, 8MM SHLD DIA	2
5	WAS-0255	OIL IMPREG. BRONZE THRUST WASH	4
6	100-0820	LONG FOLLOWER SLEEVE WHEEL	2

WARRANTY

LIMITED WARRANTY

MODEL _____
SERIAL NO. _____
DATE PURCHASED: _____

FOR A PERIOD OF TWELVE (12) MONTHS FROM DELIVERY, BUG-O SYSTEMS WARRANTS TO THE ORIGINAL PURCHASER (DOES NOT INCLUDE AUTHORIZED DISTRIBUTORS), THAT A NEW MACHINE IS FREE FROM DEFECTS IN MATERIAL AND WORKMANSHIP AND AGREES TO REPAIR OR REPLACE, AT ITS OPTION, ANY DEFECTIVE PARTS OR MACHINE. THIS WARRANTY DOES NOT APPLY TO MACHINES, WHICH AFTER OUR INSPECTION, ARE DETERMINED TO HAVE BEEN DAMAGED DUE TO NEGLIGENCE, ABUSE, OVERLOADING, ACCIDENT OR IMPROPER USAGE. ALL SHIPPING AND HANDLING CHARGES WILL BE PAID BY CUSTOMER.

BUG-O SYSTEMS MAKES NO WARRANTY OF MERCHANTABILITY AND MAKES NO OTHER WARRANTY, EXPRESSED OR IMPLIED, BEYOND THE WARRANTY EXPRESSLY SET FORTH ABOVE. BUYER'S REMEDY FOR BREACH OF WARRANTY, HEREUNDER, SHALL BE LIMITED TO REPAIR OR REPLACEMENT OF NON-CONFORMING PARTS AND MACHINES. UNDER NO CIRCUMSTANCES SHALL CONSEQUENTIAL DAMAGES BE RECOVERABLE.

HOW TO OBTAIN SERVICE:

IF YOU THINK THIS MACHINE IS NOT OPERATING PROPERLY, RE-READ THE INSTRUCTION MANUAL CAREFULLY, THEN CALL YOUR AUTHORIZED BUG-O DEALER/DISTRIBUTOR. IF HE CANNOT GIVE YOU THE NECESSARY SERVICE, WRITE OR PHONE US TO TELL US EXACTLY WHAT DIFFICULTY YOU HAVE EXPERIENCED. BE SURE TO MENTION THE MODEL AND SERIAL NUMBERS.

ADDENDUM

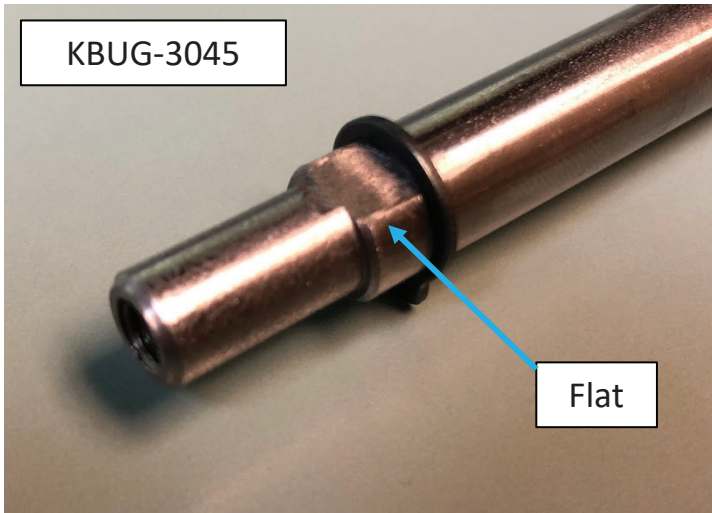

If Flat is present on the KBUG-3045, the KBUG-3030 will be required in place of the KBUG-3044 and KBUG-3029.

If Flat is not present, replacement KBUG-3044 and KBUG-3029 are still able to be ordered.

