

# INSTRUCTIONS AND PARTS MANUAL

## CW-18 CIRCLE WELDER

Please record your equipment identification information below for future reference. This information can be found on your machine nameplate.

Model Number \_\_\_\_\_

Serial Number \_\_\_\_\_

Date of Purchase \_\_\_\_\_

Whenever you request replacement parts or information on this equipment, always supply the information you have recorded above.

LIT-CW18-IPM-0724

Bug-O Systems is committed to empowering our customers by providing operator controlled mechanized solutions for their welding, cutting and custom applications.



**BUG-O SYSTEMS**

A DIVISION OF WELD TOOLING CORPORATION

280 TECHNOLOGY DRIVE CANONSBURG, PENNSYLVANIA 15317-9564 USA  
PHONE: 412-331-1776 <https://www.bugo.com> FAX: 412-331-0383



# SAFETY

**PROTECT YOURSELF AND OTHERS FROM SERIOUS INJURY OR DEATH. KEEP CHILDREN AWAY. BE SURE THAT ALL INSTALLATION, OPERATION, MAINTENANCE AND REPAIR PROCEDURES ARE PERFORMED ONLY BY QUALIFIED INDIVIDUALS.**



## **ELECTRIC SHOCK can kill.**

- 1) The equipment is not waterproof. Using the unit in a wet environment may result in serious injury. Do not touch equipment when wet or standing in a wet location.
- 2) The unused connectors have power on them. Always keep the unused connectors covered with the supplied protective panels. Operation of the machine without the protective panels may result in injury.
- 3) Never open the equipment without first unplugging the power cord or serious injury may result.
- 4) Verify the customer-supplied power connections are made in accordance with all applicable local and national electrical safety codes. If none exist, use International Electric Code (IEC) 950.
- 5) Never remove or bypass the equipment power cord ground. Verify the equipment is grounded in accordance with all applicable local and national electrical safety codes. If none exist, use International Electric Code (IEC) 950.

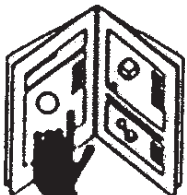

## **READ INSTRUCTIONS.**

Read the instruction manual before installing and using the equipment.



## **EQUIPMENT DAMAGE POSSIBLE.**

- 1) Do not plug in the power cord without first verifying the equipment is OFF and the cord input voltage is the same as required by the machine or serious damage may result.
- 2) Always verify both the pinion and wheels are fully engaged before applying power or equipment damage may occur.
- 3) Do not leave the equipment unattended.
- 4) Remove from the work site and store in a safe location when not in use.



## **FALLING EQUIPMENT can cause serious personal injury and equipment damage.**

Faulty or careless user installation is possible. As a result, never stand or walk underneath equipment.



## **MOVING PARTS can cause serious injury.**

- 1) Never try to stop the pinion from moving except by removing power or by using the STOP control.
- 2) Do not remove any protective panels, covers or guards and operate equipment.

## HIGH FREQUENCY WARNINGS

**SPECIAL PRECAUTIONS ARE REQUIRED WHEN USING PLASMA, TIG OR ANY WELDING PROCESS THAT USES HIGH FREQUENCY TO STRIKE AN ARC.**



**WARNING:** HIGH FREQUENCY CAN EFFECT MACHINE OPERATION AND THEREFORE, WELD QUALITY.

**Read the precautions below before installing and using the equipment.**

### **PRECAUTIONS:**

- 1) Some plasma or welding cables are strong sources of high frequency interference. NEVER lay a plasma or welding cable across the controls of the machine.
- 2) Always physically separate the plasma or welding cable leads from the machine cables. For example, the plasma or welding cable leads should NEVER be bundled with a pendant cable or the machine power cord. Maximize the separation between any machine cables and the plasma or welding cables.
- 3) Strictly follow the grounding procedures specified for the plasma or welding unit. NOTE: Some plasma and welding units produce exceptionally large amounts of high frequency noise. They may require a grounding rod be driven into the earth within six feet (2 meters) of the plasma or welding unit to become compatible with an automatic cutting or welding process.
- 4) If the high frequency is produced using a spark gap, adjust the points so the gap is as small as possible. The larger the gap, the higher the voltage and the higher the interference.
- 5) Some plasma or welding units will inject high frequency interference into the AC power line. Use separate power line branches whenever possible to power the plasma or welding source and the machine. Do not plug them into the same outlet box.
- 6) High frequency noise may enter the machine through the plasma or welding supply remote contactor leads. Some plasma and welding sources can produce noise spikes of up to several thousand volts. These sources are not compatible with automated cutting and welding equipment. It is recommended that the remote contactor leads on these plasma or welding sources not be connected to the machine. An alternate solution is to purchase a separate remote contactor isolation box.

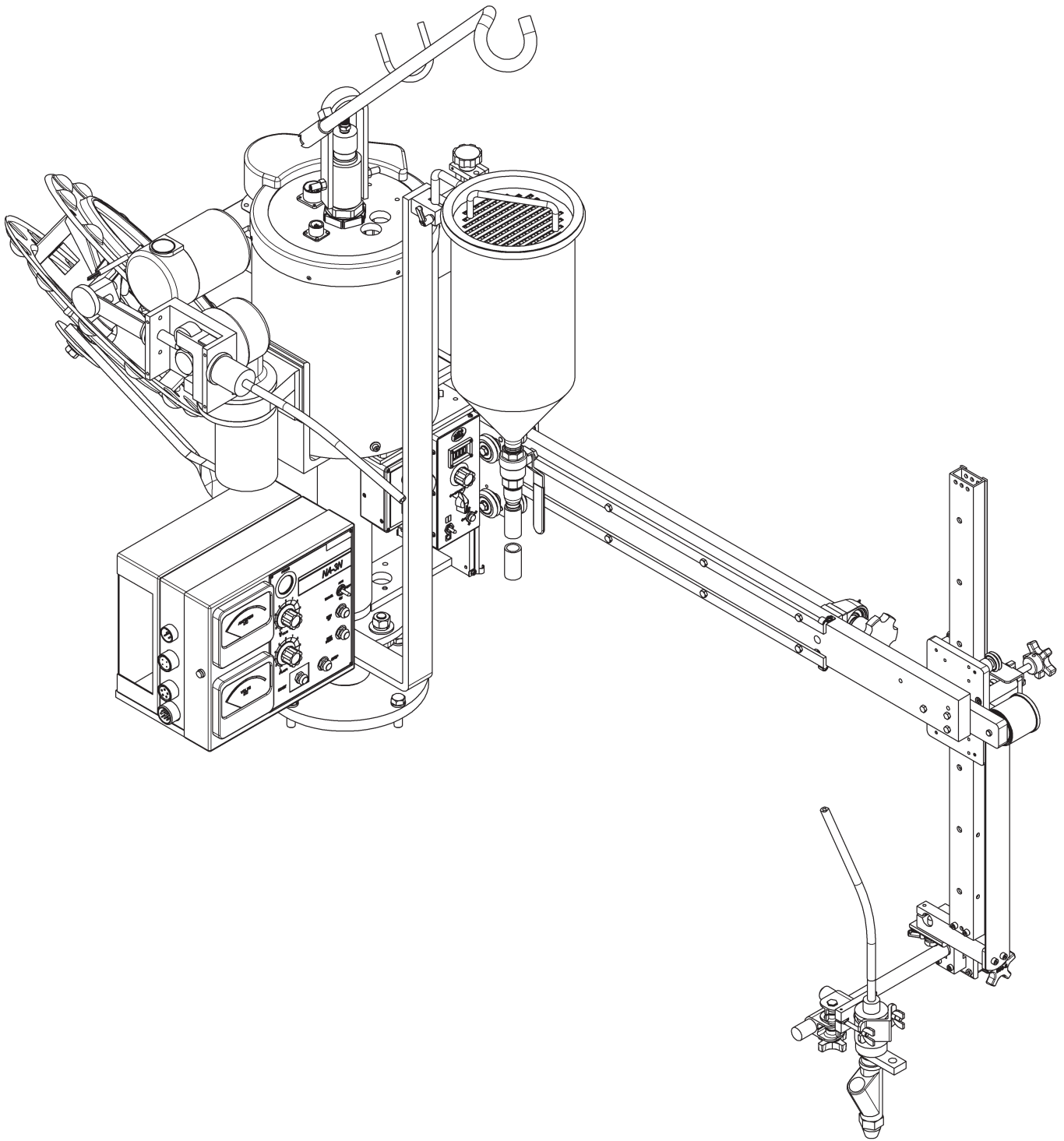

# CW-18 CIRCLE WELDER

## INSTRUCTIONS AND PARTS MANUAL

### TABLE OF CONTENTS

#### PAGE

6-7	.....	Introduction / Setup and Operation
8-9	.....	CWO-1805 Wire Feeder Controls
10	.....	CWO-6210-CW18 Rotation Controls
11	.....	Technical Data / Dimensions
12	.....	CWO-1800 CW-18 Circle Welder / Exploded View
13	.....	CWO-1800 CW-18 Circle Welder / Parts List
14	.....	CWO-1105 E-Stop / Exploded View / Parts List
15	.....	CWO-1800 CW-18 Circle Welder / Wiring Diagram / Electrical Component Chart
16	.....	CWO-3133 CW-11/CW-18 Collector with Power Racker
17	.....	CWP-3365 Heavy Duty Man. Hrzs; Std. Man. Vrt. / Exploded View / Parts List
18	.....	CWO-3165 CW-18 Housing Assembly / Exploded View / Parts List
18	.....	CWO-3205-11 7" Cam Assembly / Exploded View / Parts List
19	.....	CWO-3315 Brush Holder & Support Assembly / Exploded View / Parts List
19	.....	CWO-3359 Transmission 5:1 / Exploded View / Parts List
20	.....	CWO-3432 CW-18 Shaft Assembly / Exploded View / Parts List
20	.....	CWO-3490 Flux Hopper Assembly / Exploded View / Parts List
21	.....	CWO-3498-11 Wire Reel Assembly / Exploded View / Parts List
21	.....	CWO-3506 4066 Motor Assembly / Exploded View / Parts List
22	.....	CWO-3528 2" Flange Bearing w/Fasteners / Exploded View / Parts List
22	.....	CWO-3531 Motor & Transmission Plate Assembly / Exploded View / Parts List
23	.....	CWO-3534 Slide Bar Assembly / Exploded View / Parts List
23	.....	CWO-3537 Guard Assembly CW-18 / Exploded View / Parts List
24	.....	CWO-3538 CW-18 Camshaft & Spacer Assembly / Exploded View / Parts List
25	.....	CWO-3931 Small Retainer Block Assembly / Exploded View / Parts List / Detail View
25	.....	CWO-3969 Terminal Block Assembly / Exploded View / Parts List
26	.....	CWO-3971 Control Cable / Detail View / Parts List
26	.....	CWO-2978-ES Feeder Control Box Cable / Detail View / Parts List
27	.....	CWO-4900 33# Load Spring Assembly / Exploded View / Parts List
28	.....	CWO-6210-CW18 Rotation Control / Exploded View / Parts List
29	.....	CWO-6210-CW18 Rotation Control / Wiring Diagram / Electrical Component Chart
30	.....	CWO-3690-_ K231 Sub Arc Gun
31	.....	CWO-3710-_ Sub Arc Gun Assembly
31	.....	Accessories
32	.....	3-Jaw Expandable Chucks
33	.....	Optional Motorized Racking Equipment / CWP-3350 / Exploded View / Parts List
34	.....	Optional Motorized Racking Equipment / CWP-3351 / Exploded View / Parts List
35	.....	Optional Motorized Racking Equipment / PRS-1100 / Exploded View / Wiring Diagram
36	.....	Optional Motorized Racking Equipment / PRS-1100 / Parts List
37	.....	Optional Motorized Racking Equipment / PRS-1075 / Wiring Diagram
38	.....	Preventative Maintenance / CW-18 Circle Welder
41	.....	Warranty

## **INTRODUCTION**

The CW-18 (CWO-1800) Circle Welder is designed for welding of nozzles into vessels or domed heads utilizing SUB-ARC. The CW-18 mounts on a 3-Jaw Chuck welding diameter 10" to 50" O.D.

### **FEATURES:**

- Wire feeder with one set of drive rolls.
- 1/12 HP P.M. motor and rotational speed control.
- 600 AMP gun & cable assembly.
- Internal to NA3
- 50 ft. (15 m) power cable.
- 50 ft. (15 m) weld cable.
- Quick disconnects for all cables.
- Pre and post flow controls.
- Wire reel adaptor for 60 lb. (27 kg) spools.
- Adjustable vertical and horizontal torch positioning system.
- Rise and fall cam assembly with 7" (177.8 mm) of travel.
- Brushes and collector rings for welding current, rated at 600 AMPS 100% duty cycle.
- Brushes and collector rings for all controls, eliminates cable and hose wrap.

### **CWO-1805 WIRE FEED CONTROL BOX PROVIDES:**

- Wire Spool (amperage) control
- Voltage Control
- Wire burn back
- Weld contact
- Cold wire switch
- Weld start parameter adjustment
- Weld Crater parameter adjustment

## **SETUP AND OPERATION:**

### **POWER SOURCE:**

Please refer to the included Lincoln NA3 user's manual for welding power source requirements and system set-up.

### **GUNS AND CABLES:**

All circle welders come equipped with a gun and cable assembly.

### **ADDITIONAL CABLES:**

The circle welders are supplied with the following cables:

1. CWO-3971 50' (15 m) power cable that connects the power source to the cable connector on the top gear of the machine.
2. CWO-3040 50' (15 m) weld cable that connects the lead coming out of the top of the machine using the quick connect connector to your power supply.

## SETUP AND OPERATION, CONT'D.

### WIRE SPEED AND VOLTAGE ADJUSTMENT

The wire speed control on the front of the CWO-1805 Wire Feed Control box has a dial that is calibrated directly in inches per minute. Set the voltage using the control on the power source.

### RISE AND FALL OF THE CAM

All circle welders are equipped with a rise and fall cam assembly. The cam assembly must be aligned before any other settings can be made. To align the cam rotate the machine so the horizontal rack is parallel to the vessel, then adjust the gun holder so it is perpendicular to the horizontal rack. Position torch tip to top dead center of joint. Loosen the set screws in the brass block on the cam, and rotate the cam to the vertical position as shown. Refasten set screws.

### CAM SETTING

The cam setting is equal to distance "B" subtracted from distance "A".

#### Example:

Let A=3 and B=2  
 $3-2=1$

The cam setting is 1.

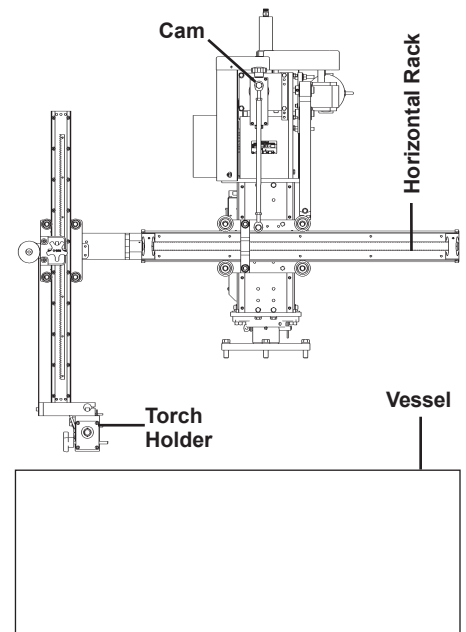
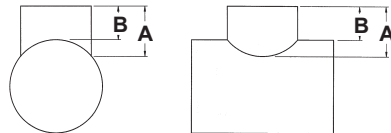

### WHEEL ADJUSTMENT

The CW-18 Racking System CWP-3365 and the Small Vertical Racker CWO-1675 are equipped with adjustable wheels. Always check these components for proper wheel adjustment before using the machine. The wheels need adjustment if you can cock or wiggle the components out of alignment. The wheels should be snug but not prohibit movement along the path of travel. The wheels with the hex stand offs are adjustable. To adjust the wheels, loosen the hex bolt (A) until the adjustable bushing (B) can be rotated. Correct the wheel alignment by rotating the adjustable bushing (B). Once adjusted, hold the adjustable bushing (B) while tightening the hex bolt (A). Recheck alignment.

### MACHINE CONTROLS

Operational parameters can be set using the two control boxes. Please refer to the section in this manual entitled CWO-6210-CW18 Rotational Control for descriptions of the various speed and directional capabilities. For the CWO-1805 Wire Feeder Control, refer to page 8 of this manual.

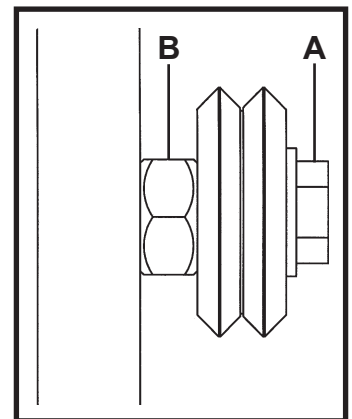

### MAKING A WELD

1. Position the gun to start position using the CWO-3365 Racking System.
2. Connect the ground cable to the workpiece. The ground cable must make good electrical contact with the work.
3. Position the electrode in the joint. The end of the electrode may be lightly touching the work.
4. With manual/auto switch in the "OFF" position, set rotation direction and speed.
5. Weld process and rotation are both started by throwing the manual/auto switch to auto.
6. Weld process and rotation are stopped by throwing the manual/auto switch to "OFF".

# CWO-1805 WIRE FEEDER CONTROLS

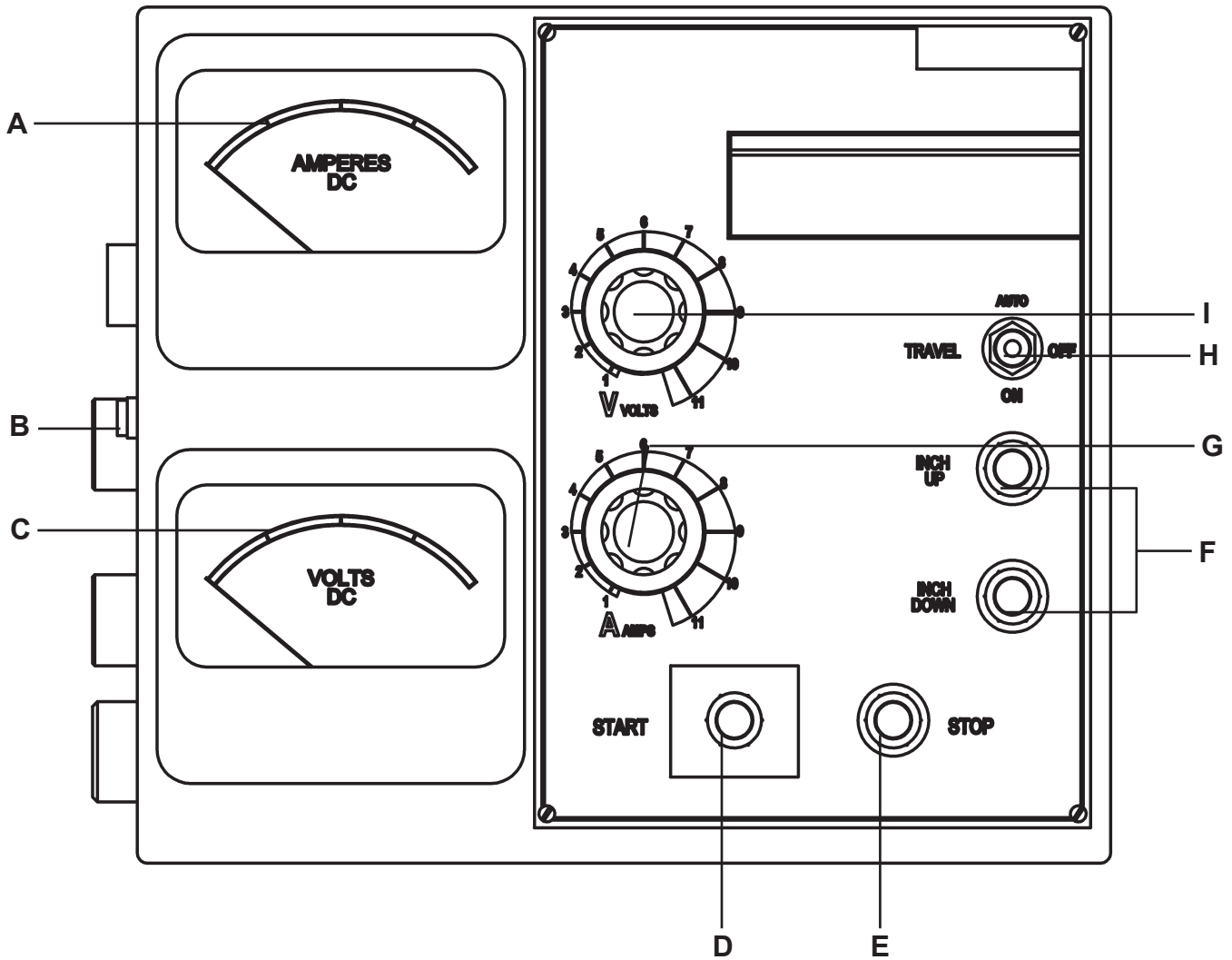

- A. Ammeter
- B. Circuit breaker
- C. Voltmeter
- D. Start
- E. Stop
- F. Inch up and inch down
- G. Current control
- H. Travel
- I. Voltage control



## **CWO-1805 WIRE FEEDER CONTROLS, CONT'D.**

**NOTE:** For further information refer to Lincoln Electric NA-3 Operator's Manual.

**A. AMMETER**

Indicates current only while welding.

**B. CIRCUIT BREAKER**

Protects the circuit from severe wire feed motor overload and short circuits. Press to reset. Locate and correct the cause for overload.

**C. VOLTMETER (Standard)**

Indicated welding voltage only while welding. Also indicates OCV below 60 volts.

**D. START**

Push-button begins the welding cycle

**E. STOP**

Push-button initiates the stopping cycle at the end of the weld.

**F. INCH UP & INCH DOWN**

Press to inch electrode at the speed set by "Inch Speed" control on inner panel.

**G. CURRENT CONTROL**

Adjusts wire feed speed to control welding current.

**H. TRAVEL**

Turn to "Off" for no travel; "Hand Travel" for travel without welding; "Automatic Travel" for welding operations. Speed and direction of travel are controlled by the travel mechanisms control.

**I. VOLTAGE CONTROL**

Adjust arc volts by controlling power source output voltage.

**J. CONTROL POWER**

Turns input control power "On" and "Off". Also used as an emergency "Off" in case of malfunction.

**\*For further information on Wire Feeder and controls, refer to Wire Feeder Operators Manual.**

# CWO-6210-CW18 ROTATION CONTROLS

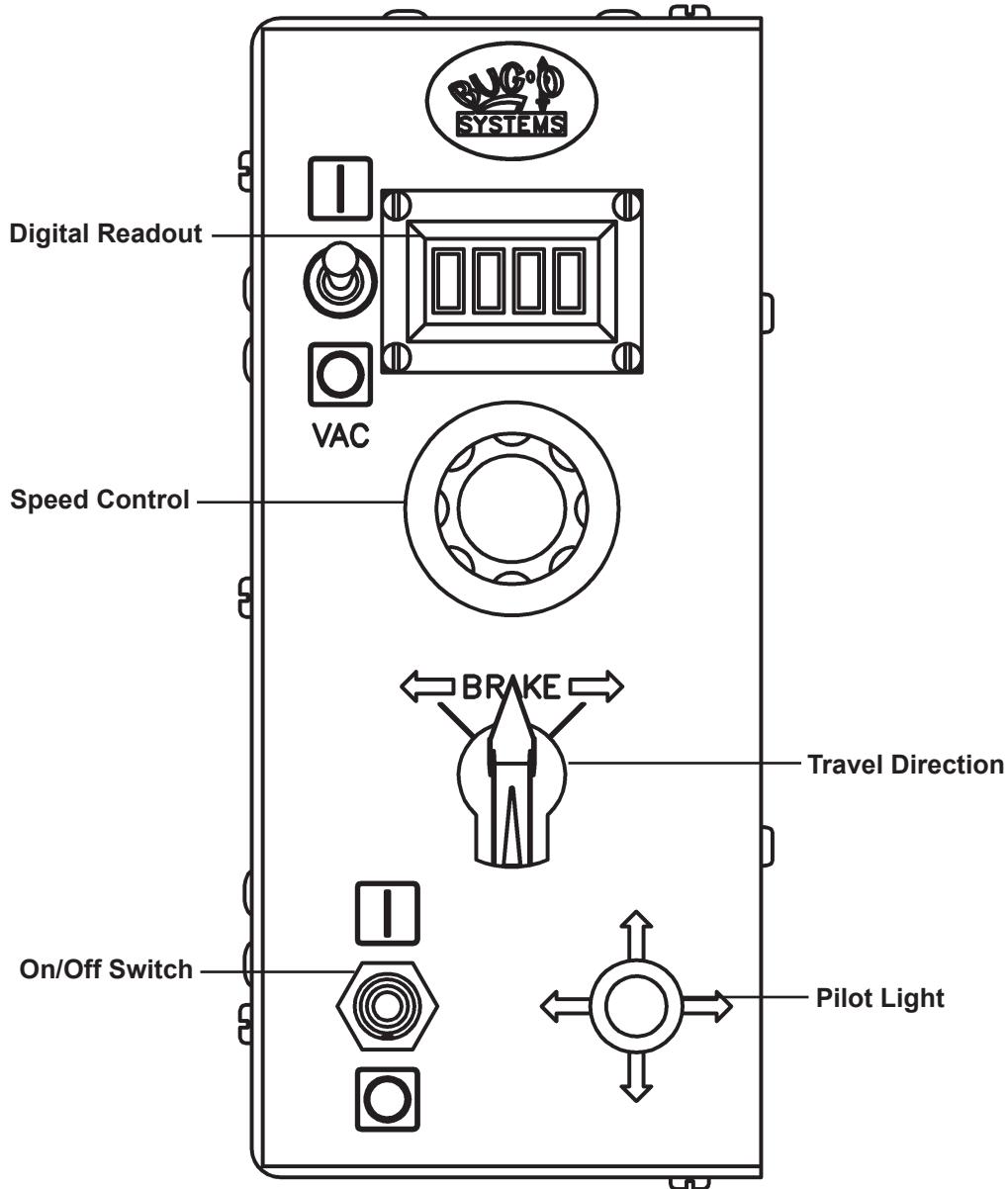

## **DIGITAL READOUT:**

Displays reference number only.

## **SPEED CONTROL:**

Controls the speed in which the machine travels. The depicted lines 0 to 100 should not be construed as inches per minute of travel. They should be considered as reference points only.

## **TRAVEL DIRECTION:**

Controls the direction in which the machine will travel. Select forward for clockwise rotation, brake for stop, and reverse for counterclockwise rotation.

## **ON/OFF SWITCH:**

The on/off switch enables/disables power to the rotation control box.

## **PILOT LIGHT:**

The pilot light indicates whether the machine is on/off as dictated by the on/off switch.

## TECHNICAL DATA

<b>Input Voltage:</b>	115 VAC
<b>Amperage:</b>	0-600 amps
<b>Voltage:</b>	0-50
<b>Wire Sizes:</b>	1/16"-5/32" (1.6-4 mm)
<b>Rotation Speed:</b>	.06-.72 rpm
<b>Cam Range:</b>	0"-7" (0-175 mm)
<b>Welding Diameter:</b>	10"-50" (254-1270 mm)
<b>Height:</b>	43" (1092 mm)
<b>Net Weight:</b>	360 lbs. (163.6 kg)
<b>Shipping Weight:</b>	490 lbs. (222.3 kg)

## DIMENSIONS

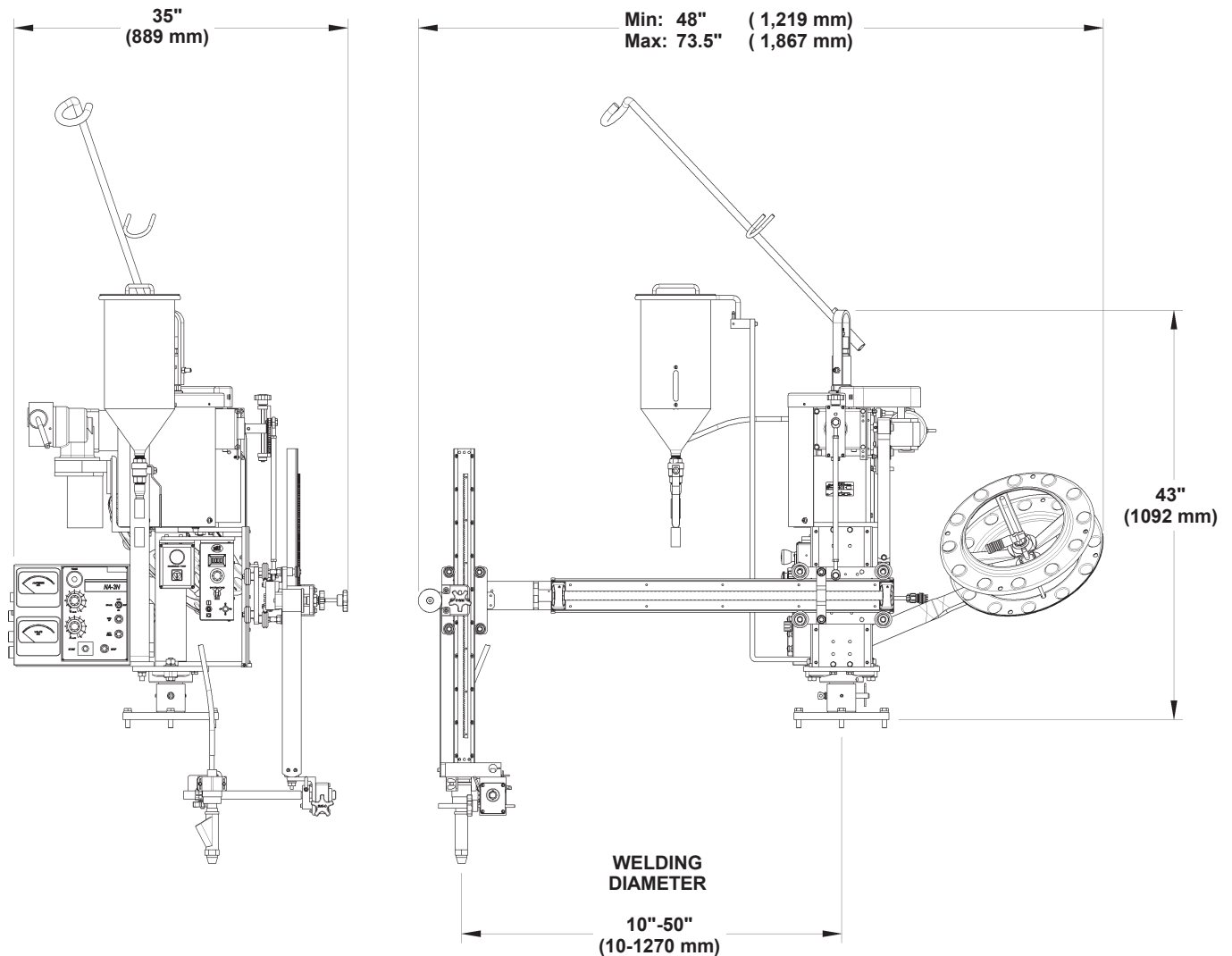

# CWO-1800 CW-18 CIRCLE WELDER / EXPLODED VIEW

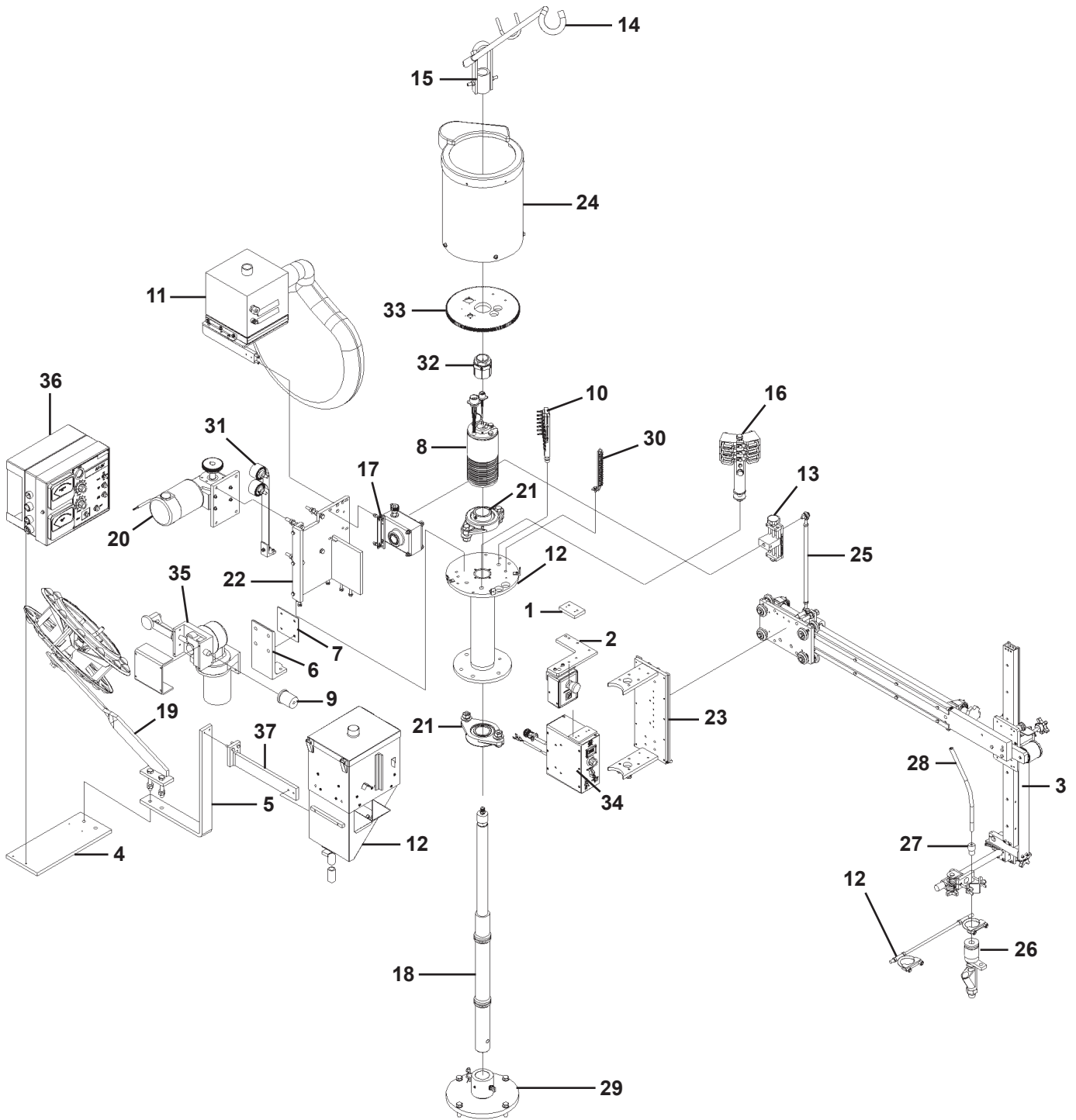

Note: Shown with optional flux recovery

## CWO-1800 CW-18 CIRCLE WELDER / PARTS LIST

<u>ITEM</u>	<u>QTY</u>	<u>PART NO.</u>	<u>DESCRIPTION</u>
1	1	CWO-1123	Control Mt. Spacer Block
2	1	CWO-1105	E-Stop Assembly
3	1	CWP-3365	Hvy Duty Manual Hrzs; Std Man Vrt
4	1	CWO-1811	NA-3S Mount Plate
5	1	CWO-1812	Flux Hopper Support
6	1	CWO-1813	Wire Feeder Bracket
7	1	CWO-1814	Insulator Plate
8	1	CWO-3133	Collector
9	1	CWO-1816	Wire Feeder Adaptor
10	1	CWO-3931	Brush Retainer Assembly
11	1	CWO-2020	Flux Recovery System (Optional)
12	1	CWO-3165	Housing Assembly
13	1	CWO-3205-11	7" Cam Assembly
14	1	CWO-3218	Cable Support Bar
15	1	CWO-3312	Lifting Lug Weldment
16	1	CWO-3315	Brush Holder & Support
17	1	CWO-3359	Transmission SW-5:1 Assembly
18	1	CWO-3432	Shaft Assembly
19	1	CWO-3498-11	Wire Reel Assembly
20	1	CWO-3506	4066 Motor Assembly
21	2	CWO-3528	2" Flange Bearing w/ Fasteners
22	1	CWO-3531	Motor & Transmission PIT. Assembly
23	1	CWO-3534	Slide Bar Mounting Assembly
24	1	CWO-3537	Guard Assembly
25	1	CWO-3538	Camshaft & Spacer Assembly
26	1	CWO-3690-5/32	Sub-Arc Nozzle
27	1	CWO-3695-1/2	Adaptor K231 1/2"
28	1	CWO-3697	QCC 72" Liner
29	1	CWO-3968	Base Plate
30	1	CWO-3969	Terminal Block Assembly
31	1	CWO-4900	33# Load Spring
32	1	CWO-5074	1-1/2" ID Trantorque
33	1	CWO-5793	Gear Aluminum
34	1	CWO-6210-CW18	Rotation Control
35	1	LDC-0040	Wire Feeder Assembly
36	1	CWO-1805	Wire Feeder Control
37	1	CWO-1820	Flux Hopper Support Assembly

# CWO-1105 E-STOP / EXPLODED VIEW / PARTS LIST

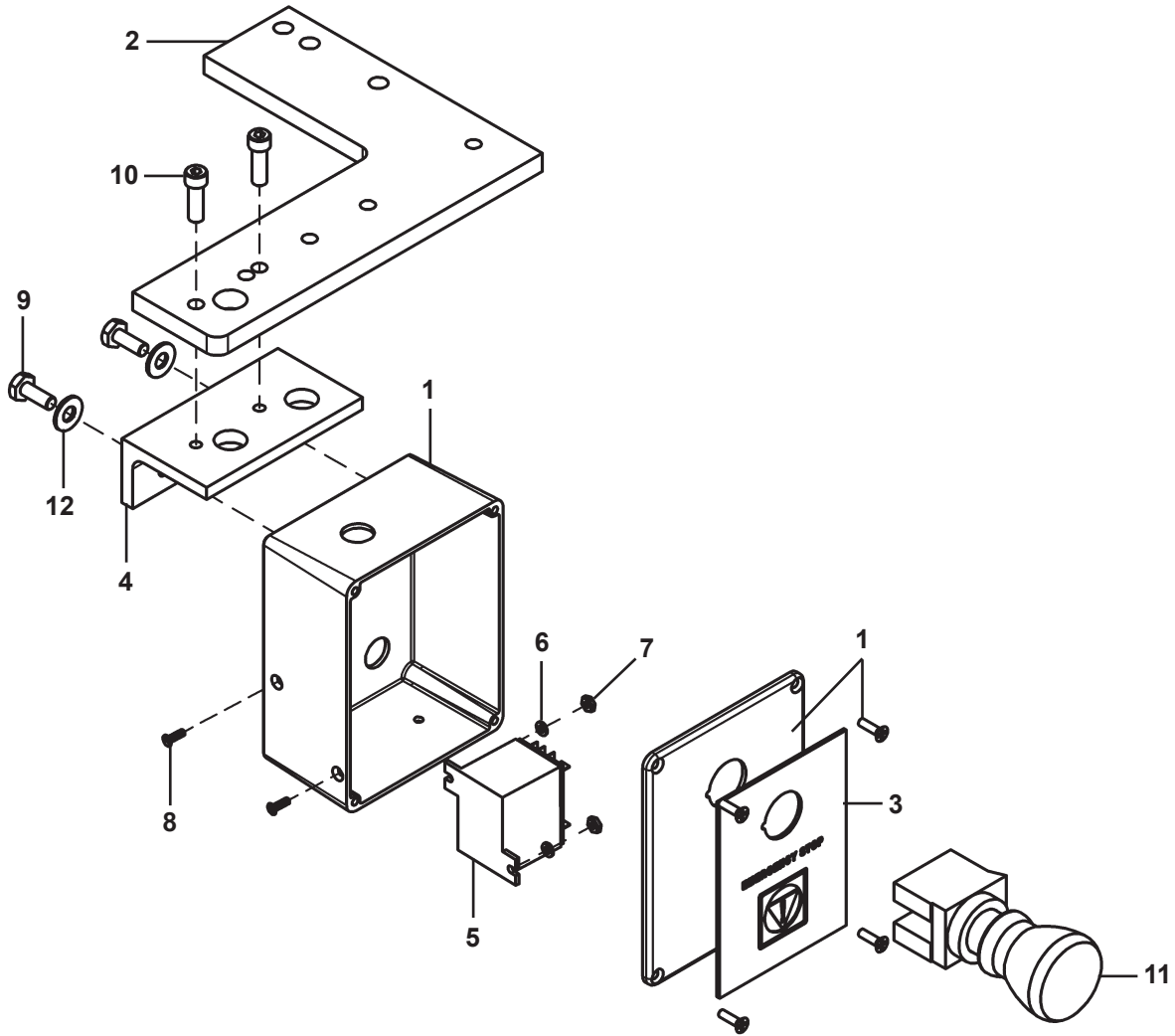

<u>ITEM</u>	<u>QTY</u>	<u>PART NO.</u>	<u>DESCRIPTION</u>
1	1	CWO-1101	E-Stop Box
2	1	CWO-1103	E-Stop "L" Bracket
3	1	CWO-1104	E-Stop Legend Plate
4	1	CWO-6426	E-Stop Mount Bracket
5	1	REL-1202	Relay, 4Pdt, 120V Panel Mount
6	2	WAS-0202	#4 Washer .250 OD Stainless
7	2	FAS-1305	Hex Nut 4-40
8	2	FAS-0804	#4-40 x 3/8 Flat Hd Slit
9	2	FAS-0356	Hex Hd Cap Scr 1/4-20 x 5/8'
10	2	FAS-0557	Soc Hd Cap 1/4-20 x 3/4
11	1	SWT-FNC2	E-Stop 2 N.C. Contacts
12	2	WAS-0240	1/4 SAE Flat

# CWO-1800 CW-18 CIRCLE WELDER / WIRING DIAGRAM / ELECTRICAL COMPONENT CHART

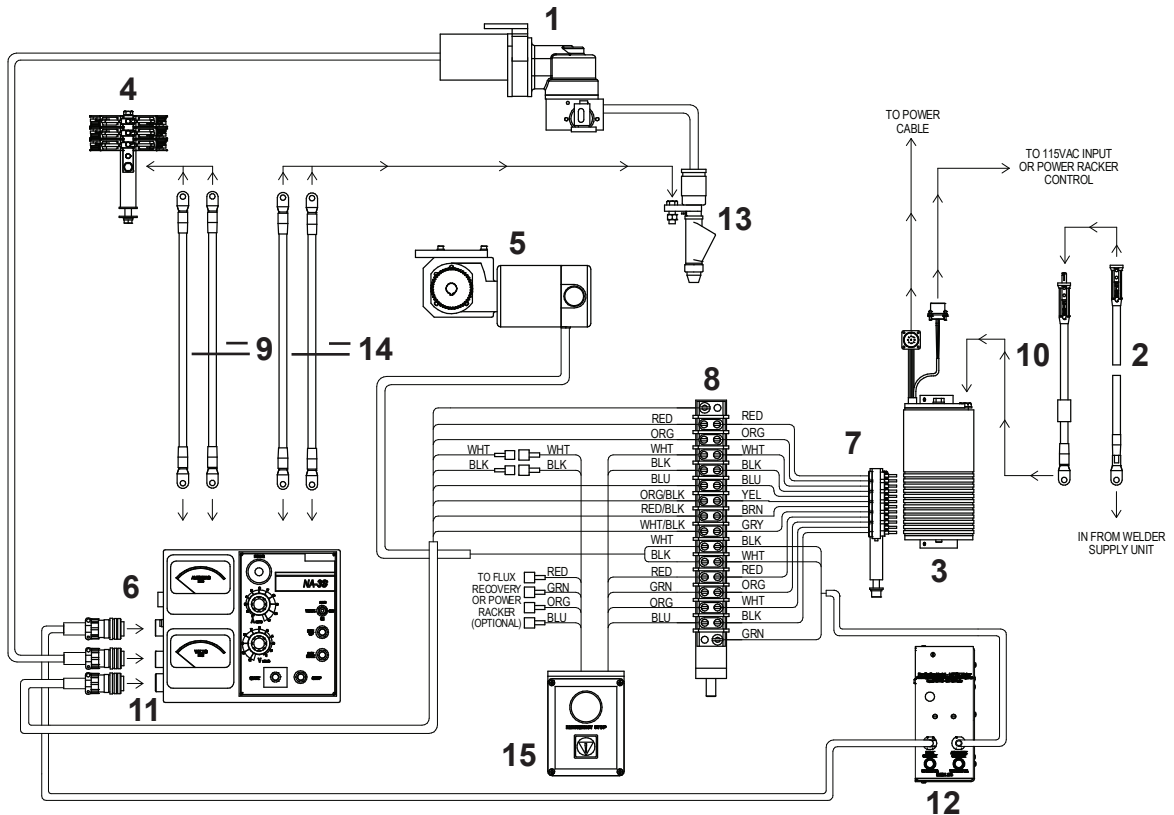

ELECTRICAL COMPONENT CHART		
ITEM	DESCRIPTION	PART NO.
1	Wire Feeder	LDC-0040
2	Weld Cable 4/0 50'	CWO-3040
3	Collector for CW-11/CW-18	CWO-3133
4	Brush Holder Support	CWO-3313
5	4066 Motor Assy.	CWO-3506
6	Wire Feeder Control	CWO-1805
6A	Start Board	LDC-0011
6B	Crater Fill Board	LDC-0012
7	Small Retainer Brush	CWO-3931
8	Terminal Block Assembly	CWO-3969
9	Weld Cable 4/0	CWO-3970
10	Weld Cable Inlet 4/0	CWO-3972
11	Feeder Control Box Cable	CWO-2978-ES
12	Rotational Control	CWO-6210-CW18
13	K231 Sub Arc Gun	CWO-3710-__
14	Weld Cable 4/0 6'	CWO-3970-72
15	CWO-1105 E-STOP	CWO-1105

# CWO-3133 CW-11/CW-18 COLLECTOR WITH POWER RACKER

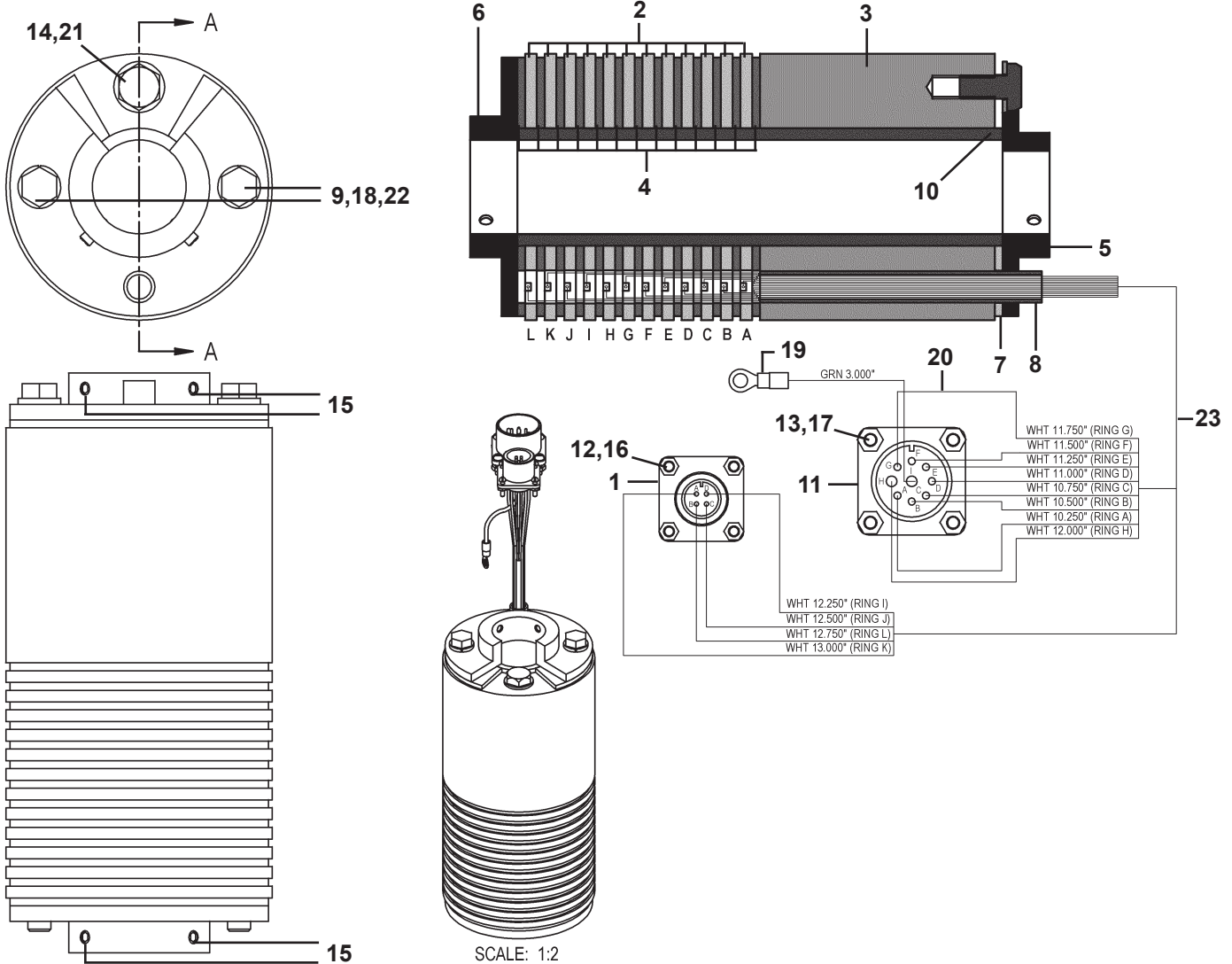

ITEM	QTY	PART NO.	DESCRIPTION
1	1	BUG-1034	Panel Connector 4-T, M
2	12	CWO-3127	Brass Ring 4.250" Dia x .188" Thk
3	1	CWO-5739	Brass Ring 4.250" Dia x 3.750 Thk
4	13	CWO-5744	Micarta Spacer
5	1	CWO-5745	Top Collector Plate
6	1	CWO-5746	Cb-2 Bottom Collector Plate
7	1	CWO-5747	Micarta Spacer W/Notch
8	1	CWO-5758	Micarta Sleeve .495" O.D. x .391" I.D. x 4.500" Lg
9	2	CWO-5760	Micarta Sleeve .495" O.D. x .391" I.D. x 8.000" Lg
10	1	CWO-5770	Micarta Sleeve 1.875" O.D. x 1.5000" I.D. x 7.750" Lg
11	1	CWO-6068	Panel Connector 9-T, M
12	4	FAS-0205	Rnd Hd Scr 4-40 x 1/2"
13	4	FAS-0215	Rnd Hd Scr 6-32 x 1/2"
14	1	FAS-0397	Hex Hd Cap Scr 3/8-16 x 3/4"
15	4	FAS-0455	Set Scr 1/4-20 x 1/2" Cup Point
16	4	FAS-1305	Hex Nut 4-40
17	4	FAS-1310	Hex Nut 6-32
18	2	FAS-3397	Hex Hd Cap Scr 3/8-16 x 8-1/2"
19	1	TERM-5494	#8 Ring, Red
20	1	W05-2025	Green Wire 20 Ga 2-1/2"
21	1	WAS-0260	3/8" Washer
22	2	WAS-0262	3/8" Split Lockwasher
23	140"	WRE-1601	16 Awg. White Teflon



**CWP-3365 HEAVY DUTY MAN HRZ; STD MAN VRT / EXPLODED VIEW / PARTS LIST**

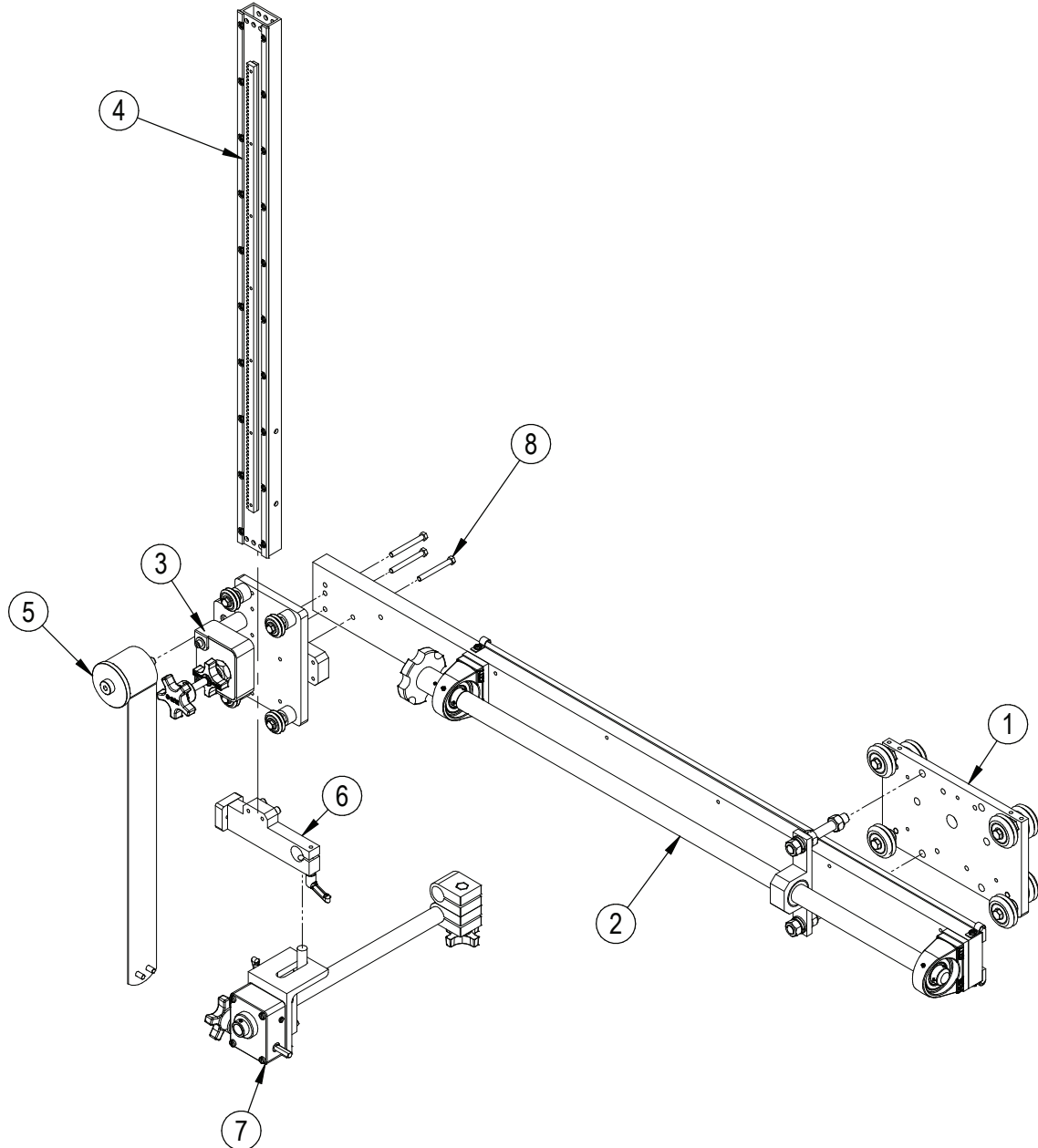

PARTS LIST			
ITEM	PART #	DESCRIPTION	QTY
1	CWP-3363	HORIZONTAL RACKER FOR HVY DUTY	1
2	CWP-3345	MANUAL HRZ HVY DUTY RACK ASSY	1
3*	CWO-1675	VERTICAL RACKER	1
4	ABR-1060	V-GUIDE WAYS 33"	1
5	CWO-3460	33# LOAD SPRING ASSY.	1
6	CWO-1695	ATTACHMENT BLOCK	1
7	CWO-3023-1	TORCH ANGLE ADJUSTER 16"	1
8	FAS-2356	HEX HD CAP SCR 1/4-20 X 2-1/4	3

## CWO-3165 CW-18 HOUSING ASSEMBLY / EXPLODED VIEW / PARTS LIST

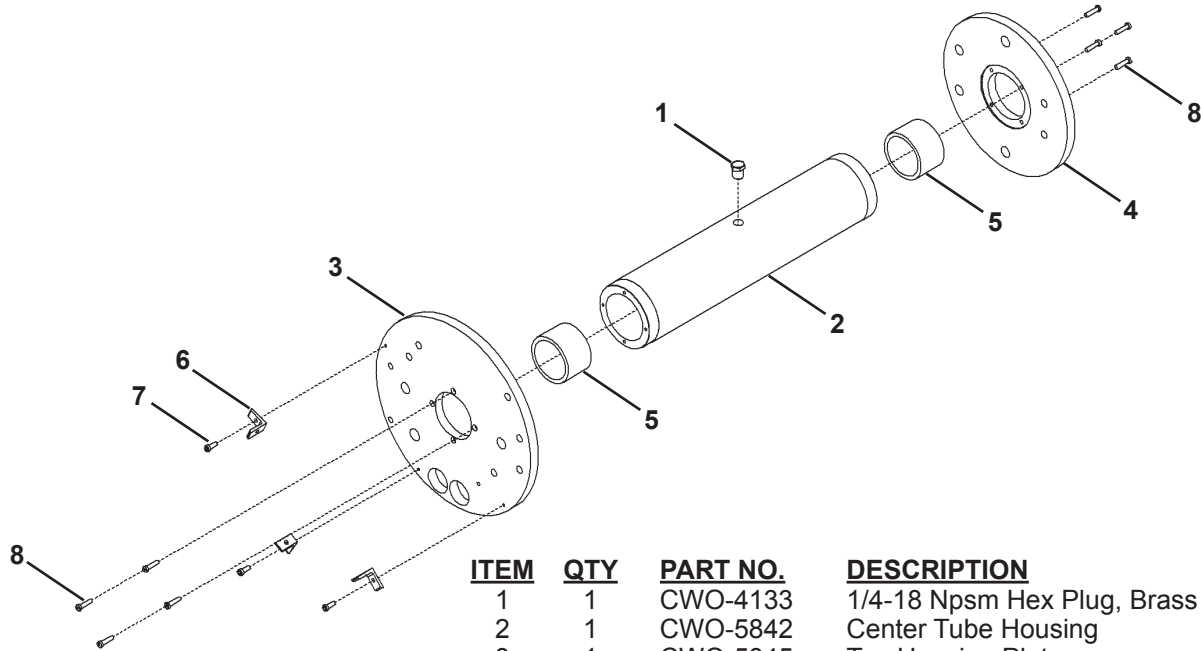

ITEM	QTY	PART NO.	DESCRIPTION
1	1	CWO-4133	1/4-18 Npsm Hex Plug, Brass
2	1	CWO-5842	Center Tube Housing
3	1	CWO-5845	Top Housing Plate
4	1	CWO-5853	Lower Housing Plate
5	2	CWO-5980	Plastic Bushing
6	3	CWO-9339	Angle For Guard
7	3	FAS-0535	Soc Hd Cap Scr 10-24 x 1/2"
8	8	FAS-0548	Soc Hd Cap Scr 10-32 x 3/4" Low Head

## CWO-3205-11 7" CAM ASSEMBLY / EXPLODED VIEW / PARTS LIST

ITEM	QTY	PART NO.	DESCRIPTION
1	2	BUG-2098	Delrin Washer 3/8"
2	1	BUG-9012	Locking Collar
3	2	CWO-4027	End Plate 4" Cam
4	1	CWO-4330	Center Block .625" Bore
5	1	CWO-4032	Knob
6	1	CWO-4328	Base Plate Rod
7	1	CWO-4331	Screw Rod
8	2	CWO-4332	Rod
9	1	CWO-5199	Scale
10	4	FAS-0434	Set Scr #10-24 x 3/8"
11	1	FAS-0444	Set Scr #10-32 x 3/8"
12	2	FAS-0495	Set Scr 3/8"-16 x 1/2"
13	4	FAS-0534	Soc Hd Cap Scr #10-24 x 3/8"

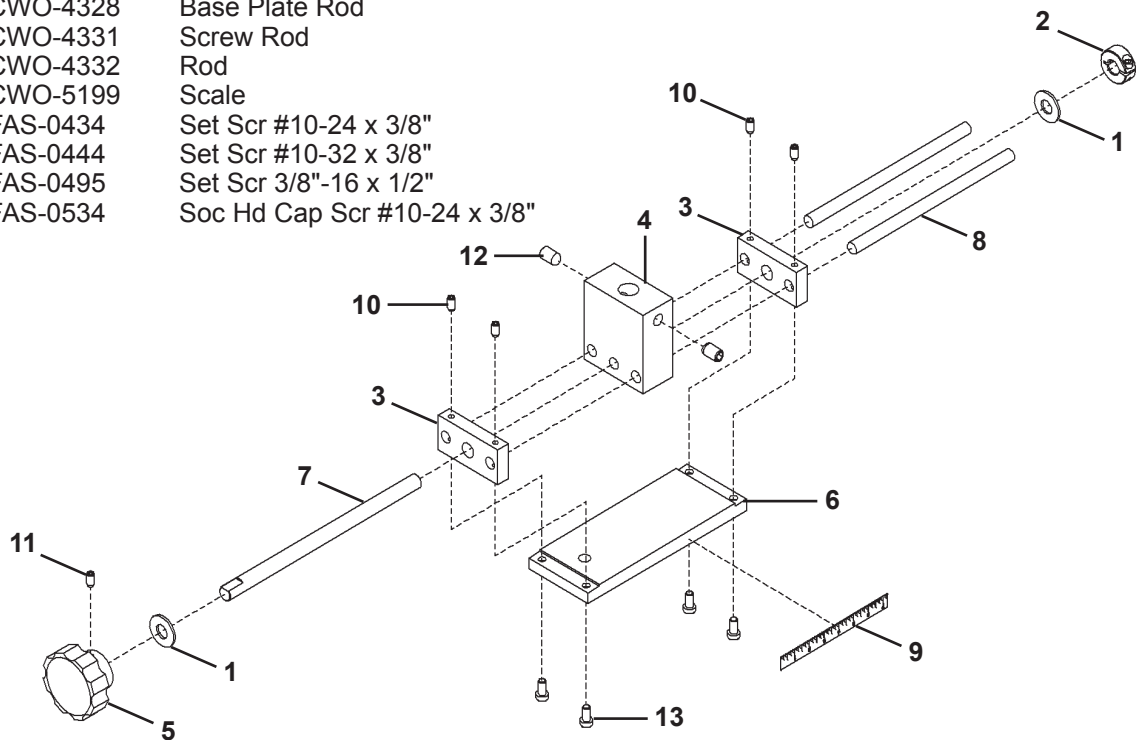

## CWO-3315 BRUSH HOLDER & SUPPORT ASSEMBLY / EXPLODED VIEW / PARTS LIST

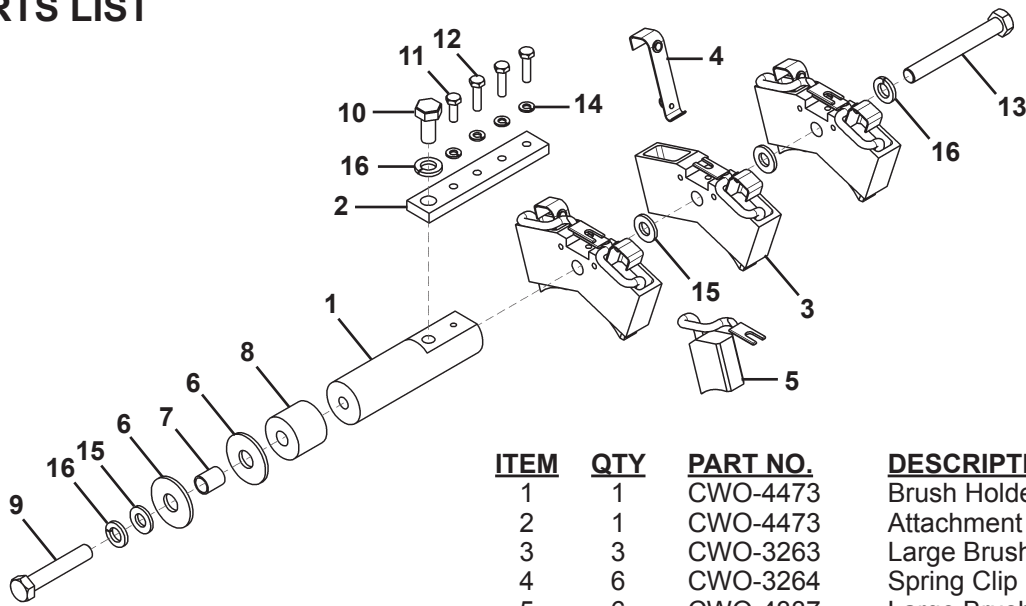

<u>ITEM</u>	<u>QTY</u>	<u>PART NO.</u>	<u>DESCRIPTION</u>
1	1	CWO-4473	Brush Holder Support
2	1	CWO-4473	Attachment Bar
3	3	CWO-3263	Large Brush Holder
4	6	CWO-3264	Spring Clip
5	6	CWO-4337	Large Brush 1-1/2" x 3/4" x 2"
6	2	CWO-5548	Micarta Spacer
7	1	CWO-5549	Micarta Bushing
8	1	CWO-4470	Support Brush Holder Extension
9	1	FAS-3308	Hex Hd Cap Scr 1/2-13 x 3"
10	1	FAS-0309	Hex Hd Cap Scr 1/2-13 x 1"
11	1	FAS-0357	Hex Hd Cap Scr 1/4-20 x 3/4"
12	3	FAS-0359	Hex Hd Cap Scr 1/4-20 x 1"
13	1	FAS-3304	Hex Hd Cap Scr 1/2-13 x 4"
14	4	WAS-0243	1/4" Split Lock Washer
15	3	WAS-0280	1/2" SAE Flat Washer
16	3	WAS-0281	1/2" Split Lock Washer

## CWO-3359 TRANSMISSION 5:1 / EXPLODED VIEW / PARTS LIST

<u>ITEM</u>	<u>QTY</u>	<u>PART NO.</u>	<u>DESCRIPTION</u>
1	1	CWO-4347	Transmission 5:1
2	4	FAS-0359	Hex Hd Cap Scr 1/4-20 x 1"
3	4	FAS-1351	1/4-20 Hex Nut
4	4	WAS-0240	1/4" SAE Washer
5	4	WAS-0243	1/4" Lock Washer
6	1	UNI-1024	Slave Pinion

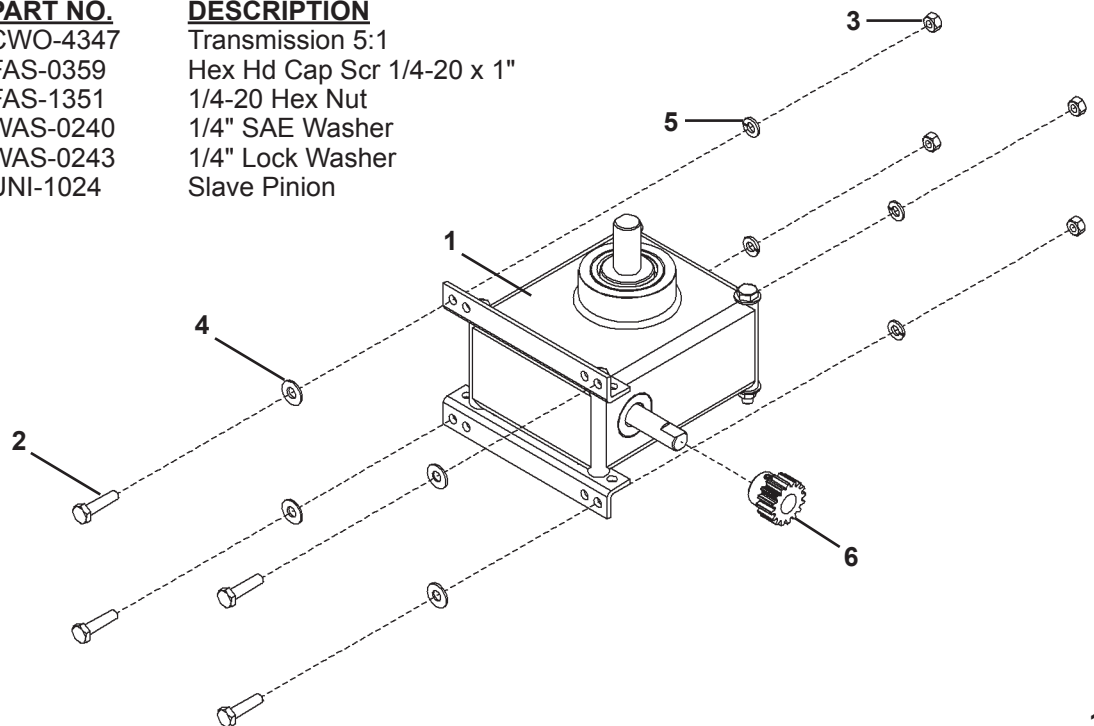

## CWO-3432 CW-18 SHAFT ASSEMBLY / EXPLODED VIEW / PARTS LIST

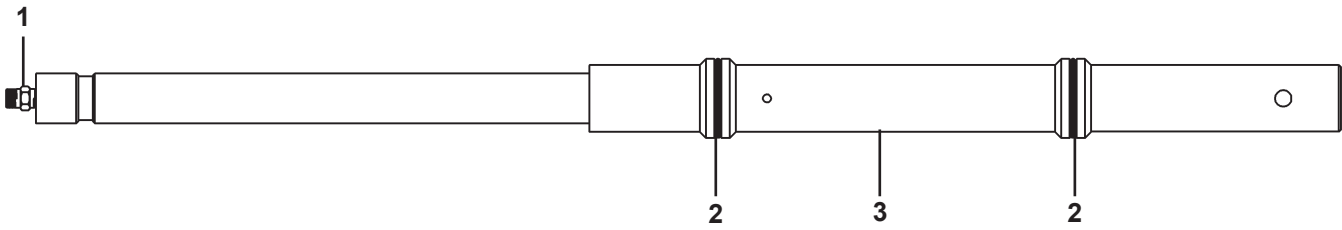

<u>ITEM</u>	<u>QTY</u>	<u>PART NO.</u>	<u>DESCRIPTION</u>
1	1	BUG-9096	Outlet Bushing, Oxygen
2	2	CWO-4507	O-Ring, Oxygen, Gas
1	3	CWO-5779	Shaft

## CWO-3490 FLUX HOPPER ASSEMBLY / EXPLODED VIEW / PARTS LIST

### PARTS LIST

<u>ITEM</u>	<u>PART #</u>	<u>DESCRIPTION</u>	<u>QTY</u>
1	CWO-3491-48	FLUX HOSE 3/4" ID X 1" OD X 48	1
2	CWO-3757	HOPPER SUPPORT ROD	1
3	CWO-3770	CLAMP BLOCK 1/2"	1
4	CWO-3768	THREADED NIPPLE 3/4" HOSE I.D.	1
5	CWO-3769	FLUX HOPPER STEEL 12"	1

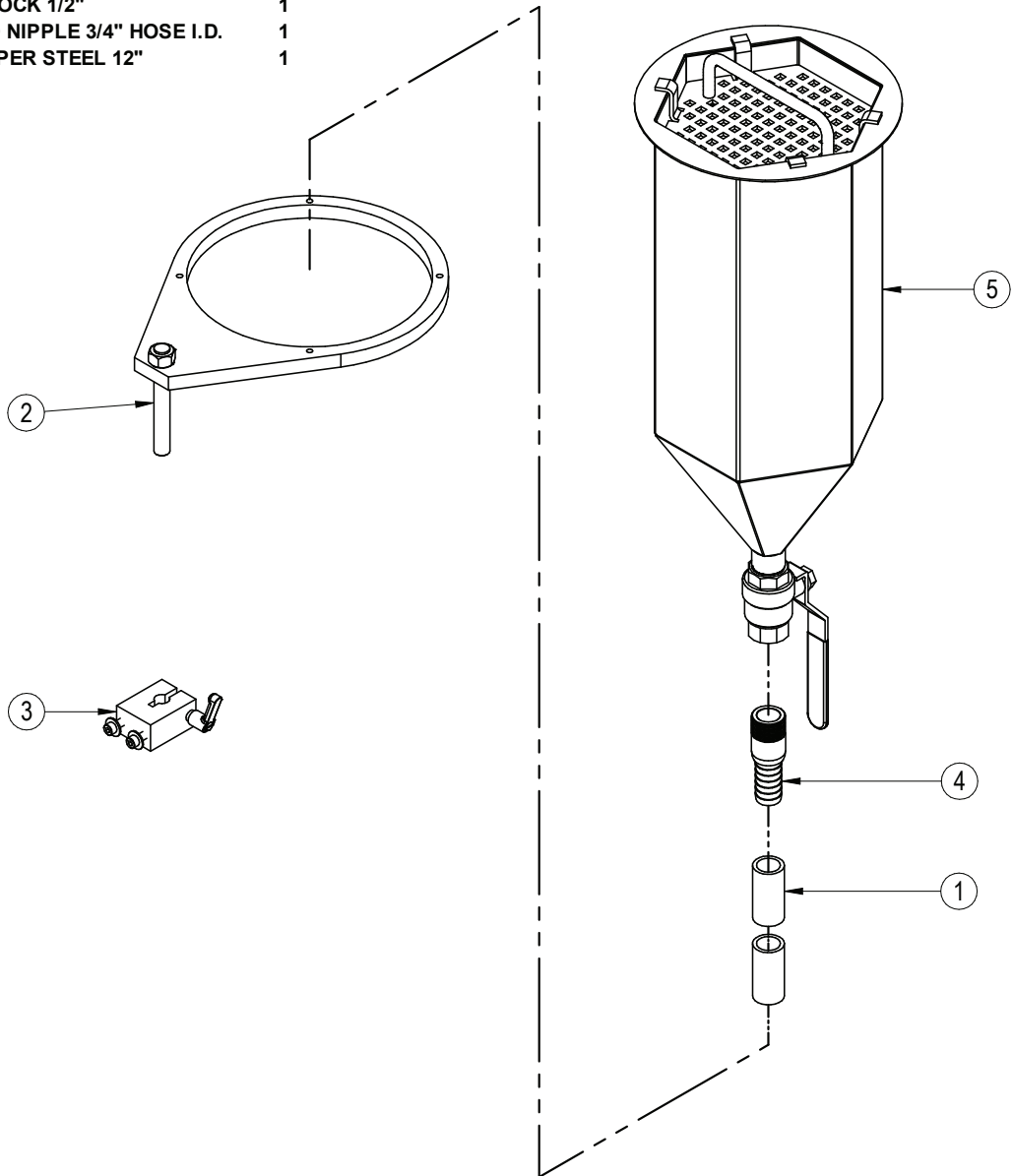

## CWO-3498-11 WIRE REEL ASSEMBLY / EXPLODED VIEW / PARTS LIST

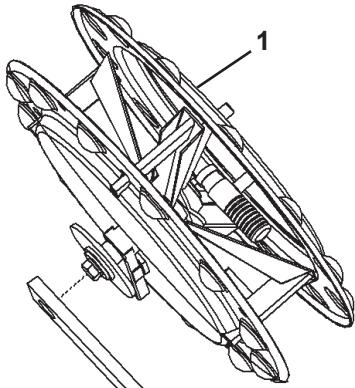

<u>ITEM</u>	<u>QTY</u>	<u>PART NO.</u>	<u>DESCRIPTION</u>
1	1	BUG-3293	Reel, 60 Lbs.
2	1	CWO-3217-11	Wire Reel Support Assembly
3	2	FAS-1301	Hex Nut 1/2-13
4	2	FAS-2305	Hex Hd Cap Scr 1/2-13 x 1-3/4"
5	2	WAS-0281	1/2" Lock Washer

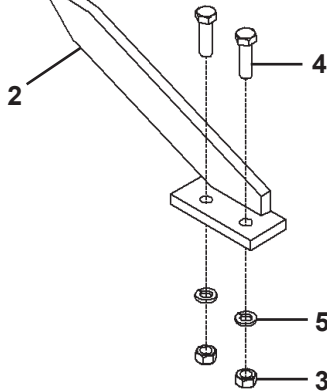

## CWO-3506 4066 MOTOR ASSEMBLY / EXPLODED VIEW / PARTS LIST

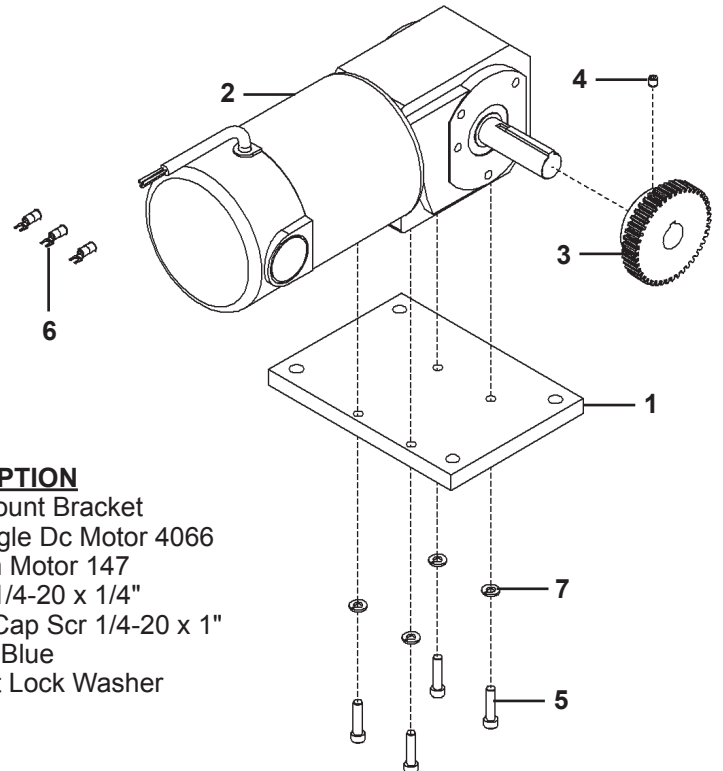

<u>ITEM</u>	<u>QTY</u>	<u>PART NO.</u>	<u>DESCRIPTION</u>
1	1	CWO-3620	Motor Mount Bracket
2	1	CWO-4846	Right Angle Dc Motor 4066
3	1	CWO-5769	Gear Pm Motor 147
4	1	FAS-0453	Set Scr 1/4-20 x 1/4"
5	4	FAS-0559	Soc Hd Cap Scr 1/4-20 x 1"
6	3	TERM WTE 0602	#6 Fork, Blue
7	4	WAS-0243	1/4" Split Lock Washer

## CWO-3528 2" FLANGE BEARING W/FASTENERS/EXPLODED VIEW/PARTS LIST

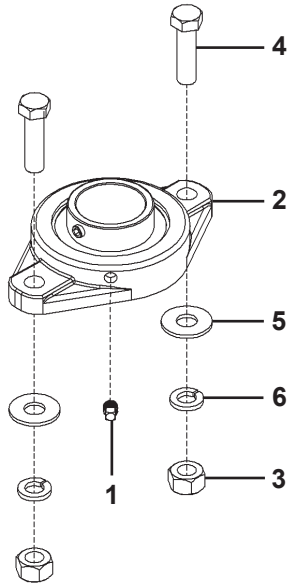

<u>ITEM</u>	<u>QTY</u>	<u>PART NO.</u>	<u>DESCRIPTION</u>
1	1	CWO-1511	1/8" Pipe Plug Black Iron
2	1	CWO-4482	Flange Bearing 2" Bore
3	2	FAS-1398	9/16-12 Hex Nut
4	2	FAS-3305	Hex Hd Cap Scr 9/16-12 x 2"
5	2	WAS-0290	9/16" SAE Washer
6	2	WAS-0291	9/16" Split Lock Washer

## CWO-3531 MOTOR & TRANSMISSION PLATE ASSEMBLY / EXPLODED VIEW / PARTS LIST

<u>ITEM</u>	<u>QTY</u>	<u>PART NO.</u>	<u>DESCRIPTION</u>
1	1	BUG-1338	I.D. Plate
2	1	CWO-5788	Cover Plate
3	1	CWO-5887	Motor & Transmission Plate
4	1	CWO-5888	End Plate
5	5	FAS-0359	Hex Hd Cap Scr 1/4-20 x 1"
6	8	FAS-1390	Hex Nut 3/8-16
7	3	FAS-2372	Hex Hd Cap Scr 5/16-18 x 1-1/4"
8	2	FAS-2374	Hex Hd Cap Scr 5/16-18 x 1-3/4"
9	4	FAS-2398	Hex Hd Cap Scr 3/8-16 x 3"
10	5	WAS-0243	1/4" Split Lock Washer
11	5	WAS-0251	5/16" Split Lock Washer
12	4	WAS-0260	3/8" Washer
13	8	WAS-0262	3/8" Split Lock Washer

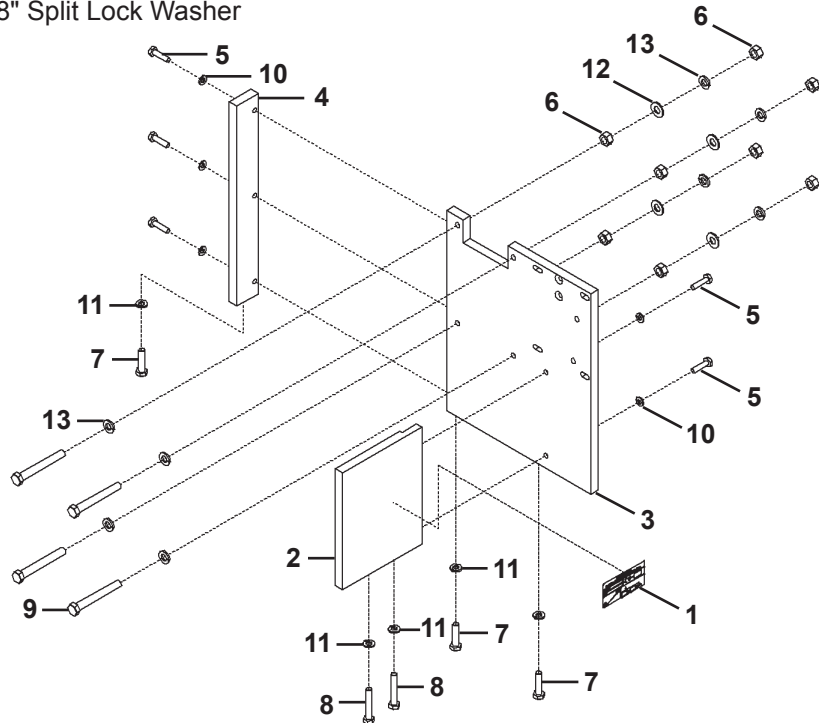

## CWO-3534 SLIDE BAR ASSEMBLY / EXPLODED VIEW / PARTS LIST

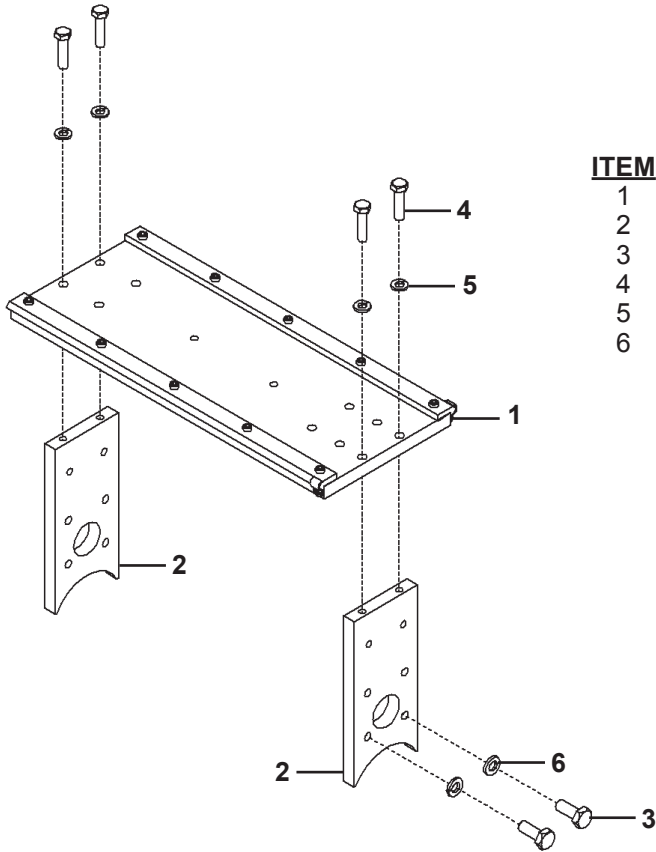

<u>ITEM</u>	<u>QTY</u>	<u>PART NO.</u>	<u>DESCRIPTION</u>
1	1	CWO-3912	Slide Bar Assembly
2	2	CWO-9033	Top / Bottom Vertical Slide Plate
3	2	FAS-0399	Hex Hd Cap Scr 3/8-16 x 1"
4	4	FAS-2372	Hex Hd Cap Scr 5/16-18 x 1-1/4"
5	4	WAS-0251	5/16" Split Lock Washer
6	2	WAS-0262	3/8" Split Lock Washer

## CWO-3537 GUARD ASSEMBLY CW-18 / EXPLODED VIEW / PARTS LIST

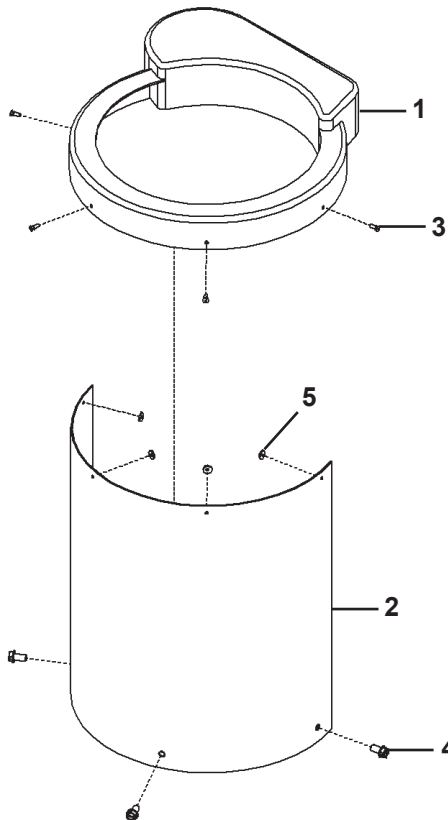

<u>ITEM</u>	<u>QTY</u>	<u>PART NO.</u>	<u>DESCRIPTION</u>
1	1	CWO-5094	Upper Guard
2	1	CWO-9142	Lower Guard
3	4	FAS-1376	Rivet 1/8" Dia x 3/8"
4	3	FAS-1455	T.C. Slit Hex 1/4-20 x 1/4" w/Washer
5	4	FAS-0261	3/8" Washer / .056 Thk

**CWO-3538 CW-18 CAMSHAFT & SPACER ASSEMBLY / EXPLODED VIEW / PARTS LIST**

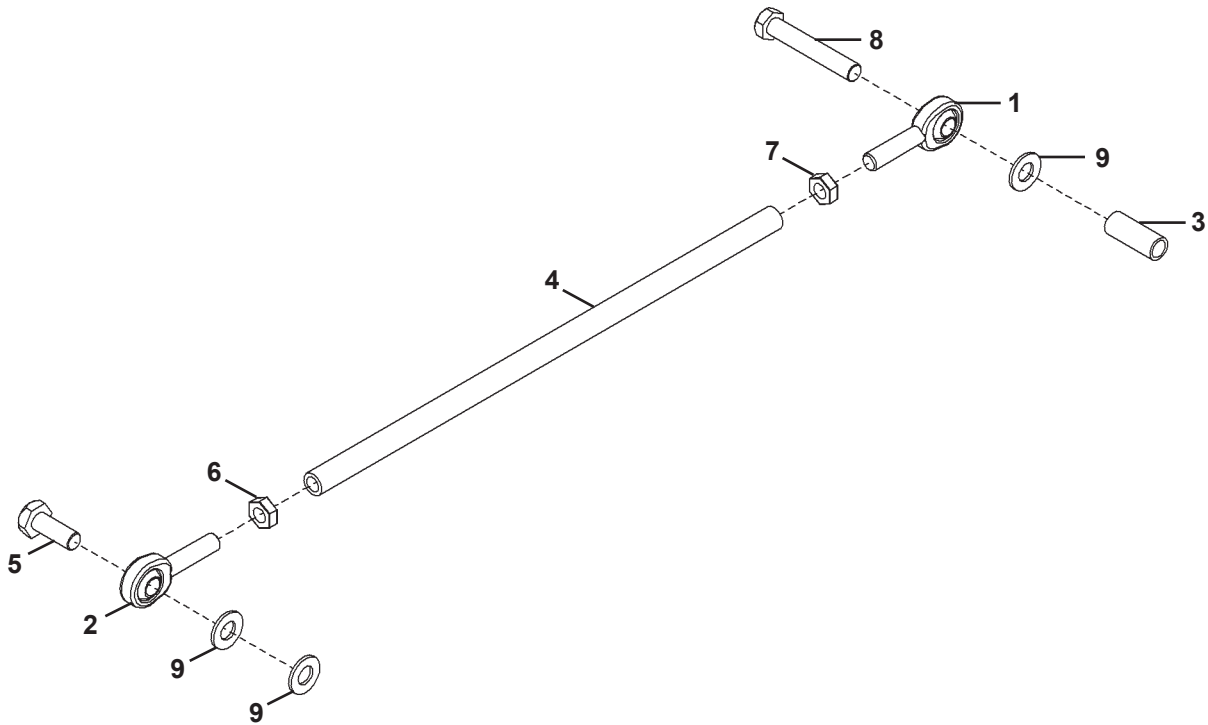

<b>ITEM</b>	<b>QTY</b>	<b>PART NO.</b>	<b>DESCRIPTION</b>
1	1	CWO-4352	Ball Joint End 3/8-16 R.H.
2	1	CWO-5042	Ball Joint End 3/8-16 L.H.
3	1	CWO-9081	Spacer
4	1	CWO-9353	Pipe For Cam Shaft
5	1	FAS-0399	Hex Hd Cap Scr 3/8-16 x 1"
6	2	FAS-1395	Hex Nut 3/8-24
7	1	FAS-1396	Hex Nut 3/8-24 LH
8	1	FAS-2396	Hex Hd Cap Scr 3/8-16 x 2-1/4"
9	3	WAS-0260	3/8" SAE Washer



## CWO-3931 SMALL BRUSH ASSEMBLY / EXPLODED VIEW / PARTS LIST

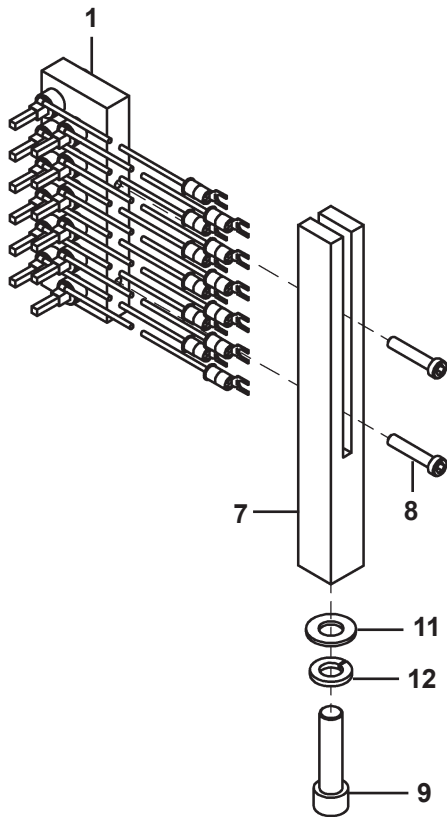

ITEM	QTY	PART NO.	DESCRIPTION
1	1	CWO-3947	12 Position Small Brush Assembly
2	12	CWO-5831	1/8" x 1/8" x 1/8" Brush
3	12	CWO-5874	1/8" Brush Holder
4	12	CWO-5875	Cap
5	12	CWO-5876	Clip
6	1	CWO-9067	Small Brush Retainer Block
7	1	CWO-9082	Retainer Support
8	2	FAS-0359	Soc Hd Cap Scr 10-24 x 1"
9	1	FAS-0593	Soc Hd Cap Scr 3/8-16 x 1-1/2"
10	12	TERM-WTE-1508	#8 Fork, Blue
11	1	WAS-0260	3/8" SAE Washer
12	1	WAS-0262	3/8" Split Lock Washer

## CWO-3931 SMALL RETAINER BLOCK ASSEMBLY / DETAIL VIEW

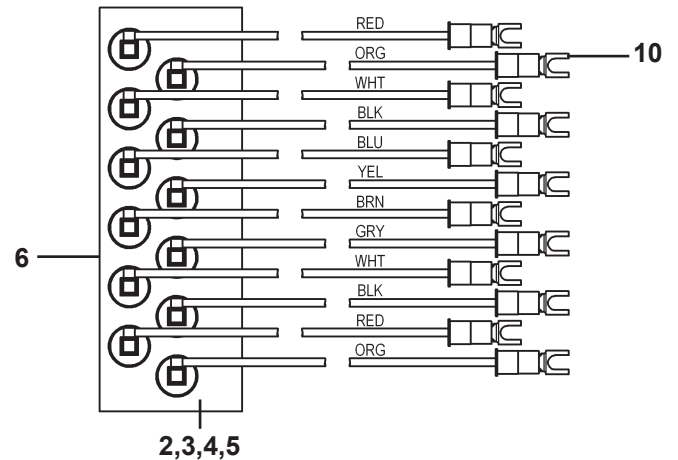

## CWO-3969 TERMINAL BLOCK ASSEMBLY / EXPLODED VIEW / PARTS LIST

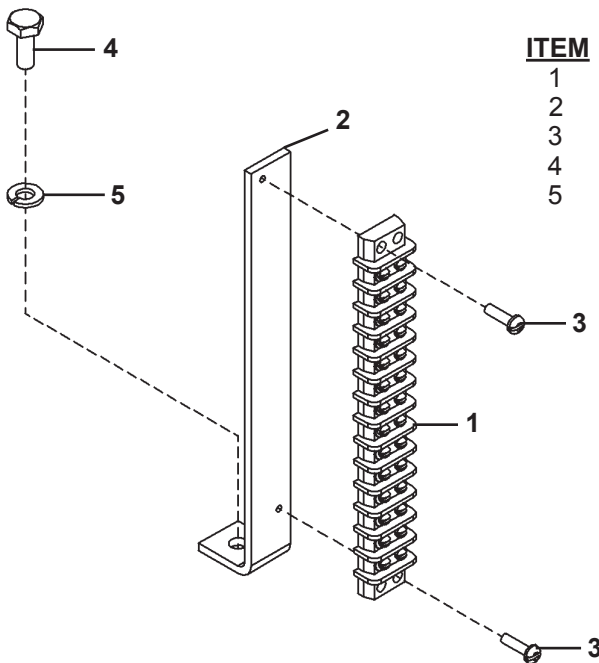

ITEM	QTY	PART NO.	DESCRIPTION
1	1	CWO-6726	Terminal Block 14-Pin
2	1	CWO-9071	Terminal Block Support CW-18
3	2	FAS-0215	Rnd Hd Scr 6-32 x 1/2"
4	1	FAS-0356	Hex Hd Cap Scr 1/4-20 x 5/8"
5	1	WAS-0243	1/4" Split Lock Washer

# CWO-3971 CONTROL CABLE / DETAIL VIEW / PARTS LIST

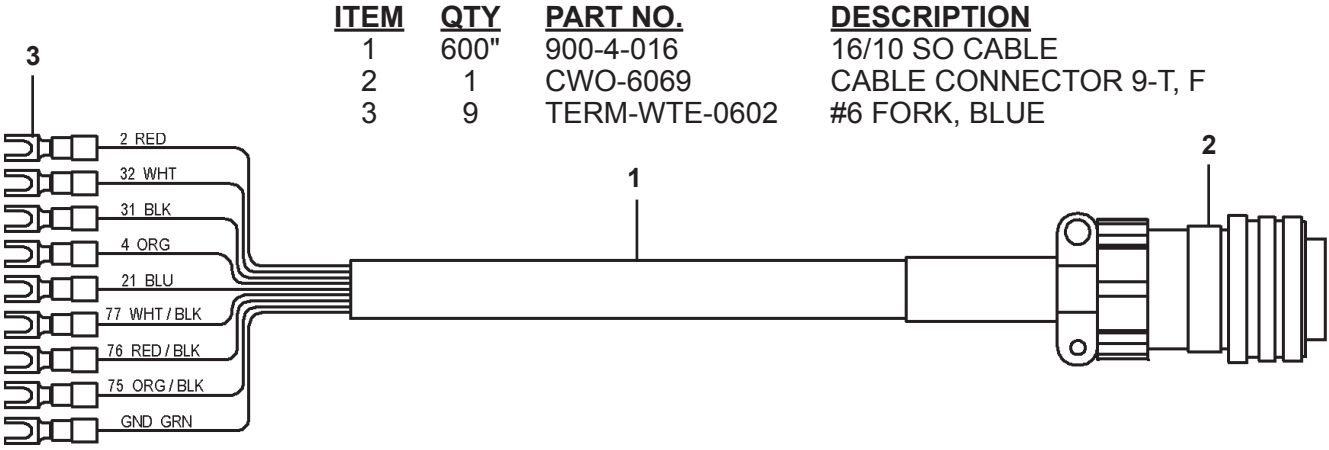

ITEM	QTY	PART NO.	DESCRIPTION
1	600"	900-4-016	16/10 SO CABLE
2	1	CWO-6069	CABLE CONNECTOR 9-T, F
3	9	TERM-WTE-0602	#6 FORK, BLUE

**WIRE CHART**

2 RED	CONTACTOR
4 ORG	CONTACTOR
32 WHT	110 VAC
31 BLK	110 VAC
21 BLU	REMOTE VOLTAGE
75 ORG / BLK	REMOTE VOLTAGE
76 RED / BLK	REMOTE VOLTAGE
77 WHT / BLK	REMOTE VOLTAGE
GRN	GROUND

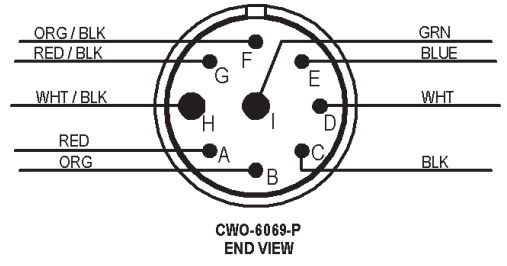

# CWO-2978 FEEDER CONTROL BOX CABLE / DETAIL VIEW / PARTS LIST

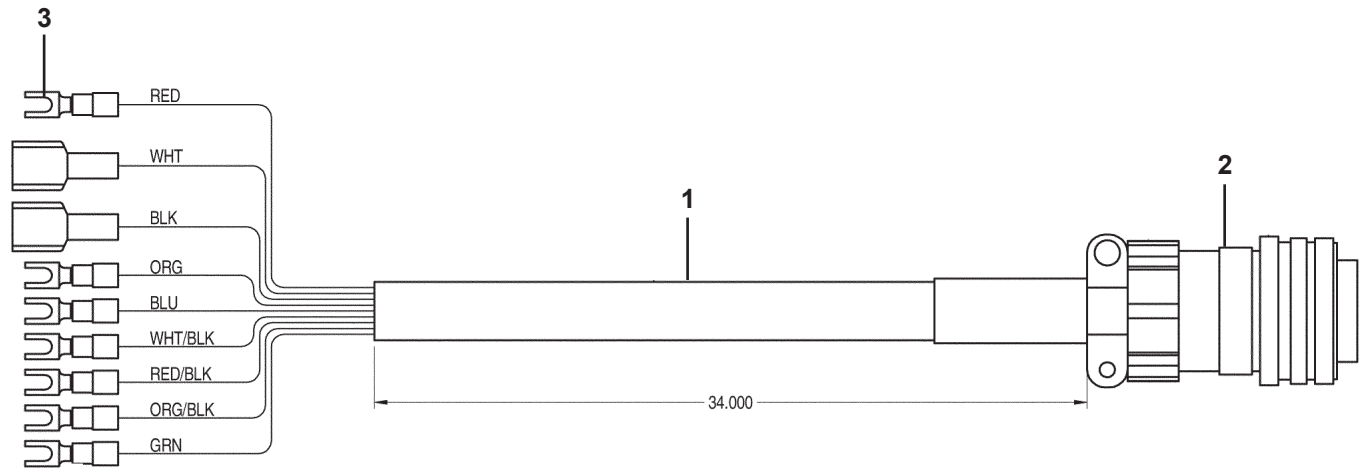

ITEM	QTY	PART NO.	DESCRIPTION
1	32"	900-4-016	16/10 So Cable
2	1	CWO-6069	Cable Connector 9-T, F
3	9	TERM-WTE-0602	#6 Fork, Blue

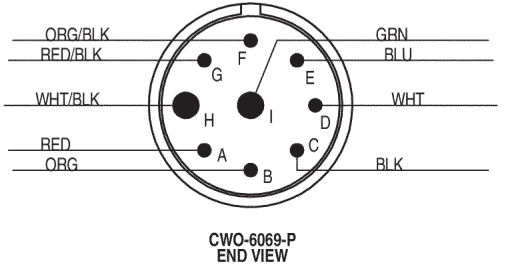

# CWO-4900 33# LOAD SPRING ASSEMBLY / EXPLODED VIEW / PARTS LIST

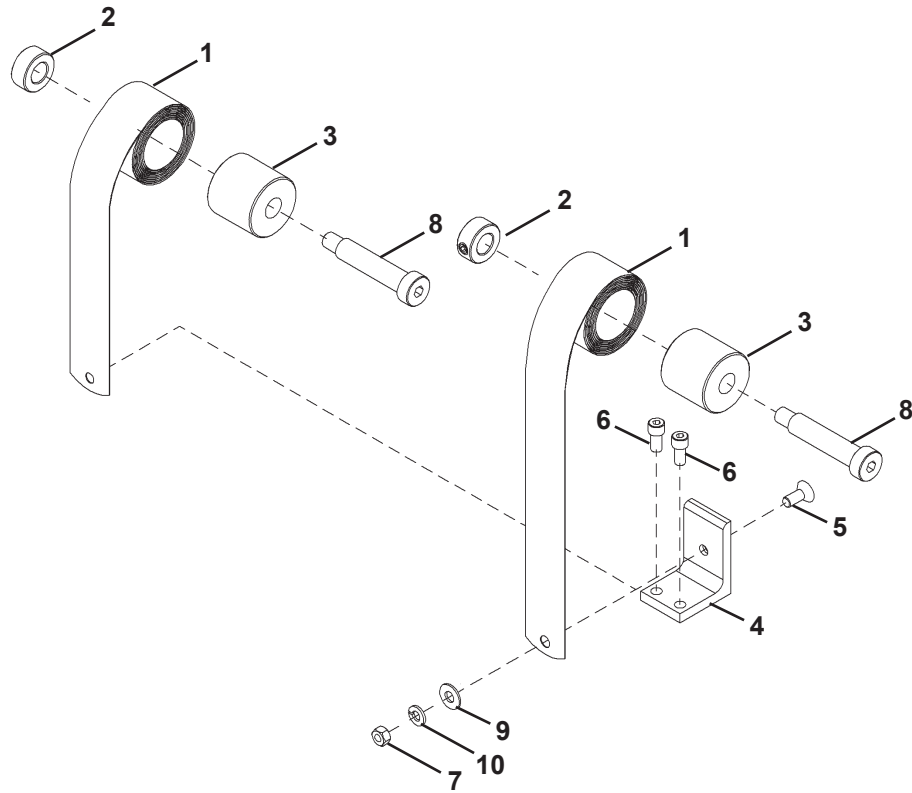

<u>ITEM</u>	<u>QTY</u>	<u>PART NO.</u>	<u>DESCRIPTION</u>
1	2	CWO-4074	Spring 16.5#
2	2	CWO-5707	Collar w/ Set Screw
3	2	CWO-5773	Insert 1-1/2" OD
4	1	CWO-9230	Spring Retainer Angle
5	1	FAS-0956	Flt Hd Soc Scr 1/4-20 x 5/8"
6	2	FAS-0555	Soc Hd Cap Scr 1/4-20 x 1/2"
7	1	FAS-1351	Hex Nut 1/4-20
8	2	FAS-2697	Soc Hd Shr 1/2 x 2 x 3/8-16
9	1	WAS-0240	1/2 SAE Washer
10	1	WAS-0243	1/4" Split Lock Washer

# CWO-6210-CW18 ROTATION CONTROL / EXPLODED VIEW / PARTS LIST

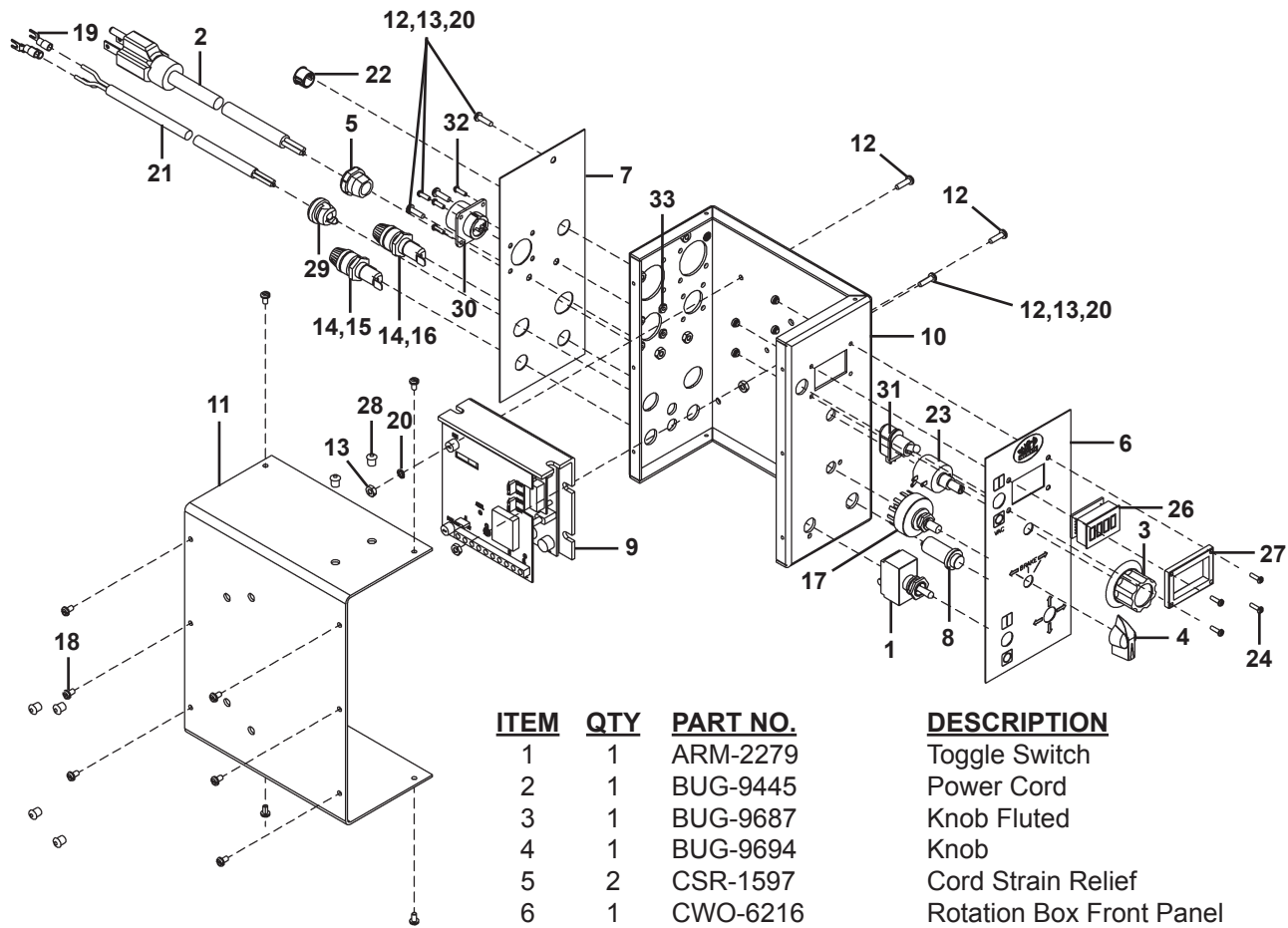

<u>ITEM</u>	<u>QTY</u>	<u>PART NO.</u>	<u>DESCRIPTION</u>
1	1	ARM-2279	Toggle Switch
2	1	BUG-9445	Power Cord
3	1	BUG-9687	Knob Fluted
4	1	BUG-9694	Knob
5	2	CSR-1597	Cord Strain Relief
6	1	CWO-6216	Rotation Box Front Panel
7	1	CWO-5547B	Rotation Box Rear Panel
8	1	CWO-6206	Indicator Light
9	1	CWO-6527	0-90V Spd Ctrl w. Isolator
10	1	CWO-6839	Rotation Control Case
11	1	CWO-6802	Rotation Box Cover
12	6	FAS-0115	#6-32 x 1/2" Pan Head Zinc
13	6	FAS-1310	Hex Nut 6-32
14	2	FHO-0188	Fuse Holder
15	1	MPD-1026	Fuse 2 Amp
16	1	FUS-0257	Fuse 3 Amp
17	1	MUG-1258-1	Rotary Switch Assembly
18	10	SCW-WTE-0264	#6-32 x 1/4" Sht Mt Scr
19	3	TERM-WTE-0197	#6 Red Fork
20	6	WAS-0211	#6 Internal Star Washer
21	42"	WRE-WTE-0501	18/3 SJO 300V Cord
22	1	MUG-1589	Hole Plug .500"
23	1	BUG-1562	Multi-turn Potentiometer
24	4	FAS-0104	#4-40 x 3/8" Pan Hd
25	4	SCF-1001	#4-40 Self Clinching Nut
26	1	BUG-1764	Meter Display Board
27	1	MDS-1011	Display Bezel
28	6	BUG-3331	Hole Plug 1/4"
29	1	CSR-1598	Cord Strain Relief Bushing
30	1	BUG-9486	Panel Connector, 2T, M
31	1	ABP-1069	Toggle Switch, SPST
32	4	FAS-0204	Rmd Slit Jd Scr 4-40 x 3/8" Zinc
33	4	FAS-1305	Hex Nut 4-40

# CWO-6210-CW18 ROTATION CONTROL / WIRING DIAGRAM / ELECTRICAL COMPONENT CHART

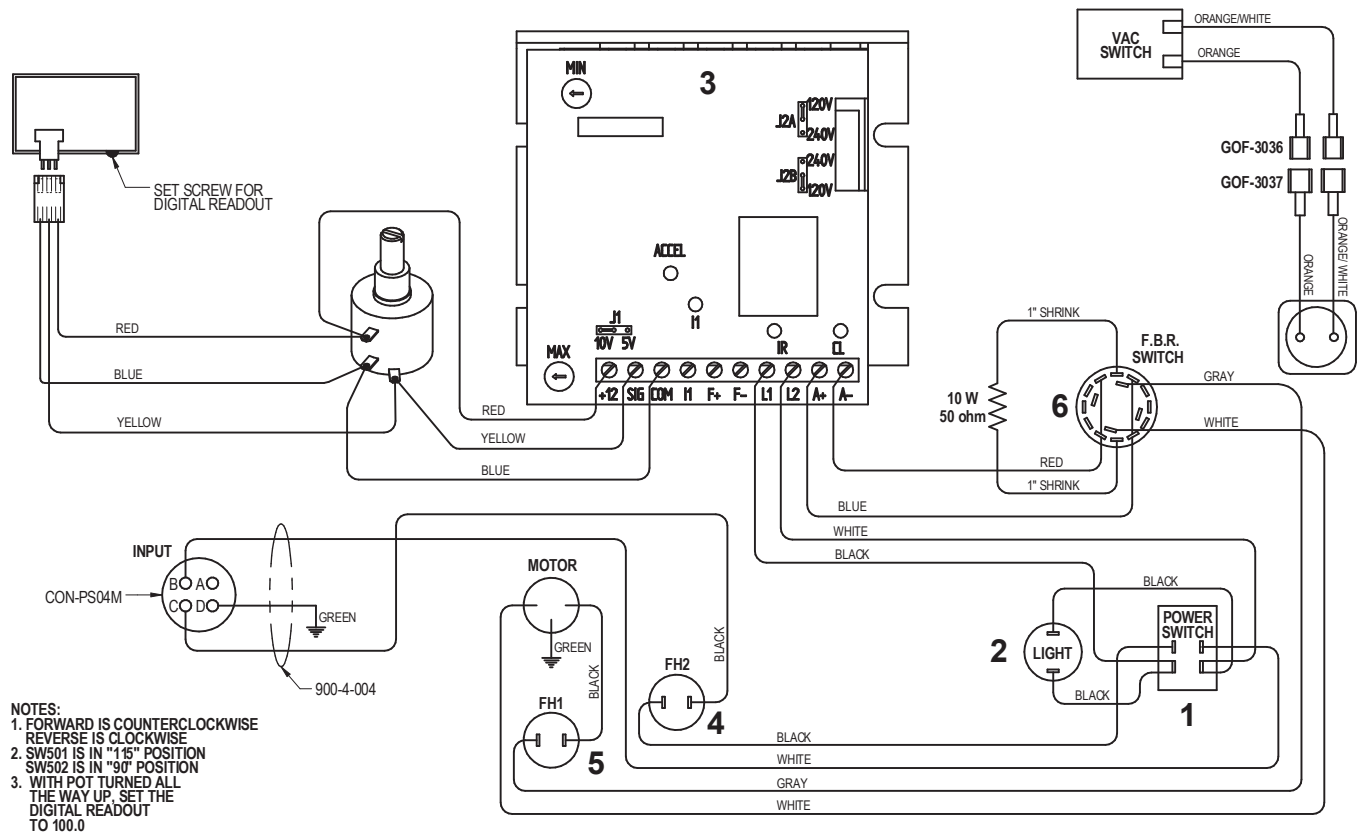

= INDICATES ITEMS THAT ARE SUPPLIED TOGETHER

## ELECTRICAL COMPONENT CHART

ITEM	DESCRIPTION	PART NO.
1	Toggle Switch	ARM-2279
2	Red Neon Lamp	CWO-6206
3	Speed Control Board w/Resistor	CWO-6527
4	Fuse 2 amp	MPD-1026
5	Fuse 3 amp	FUS-0257
6	Rotary Switch	MUG-1258-1

# CWO-3690-\_ K231 SUB ARC GUN

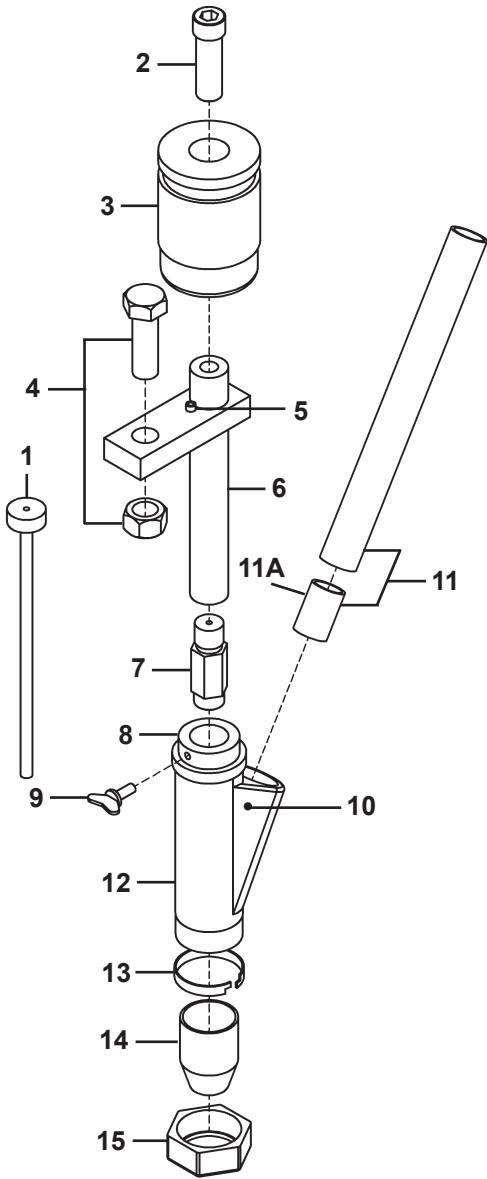

<u>ITEM</u>	<u>QTY</u>	<u>PART NO.</u>	<u>DESCRIPTION</u>
1	1	PXS-15106-3/32	Nozzle Insert
2	1	PXT-10570	Socket Head Screw
3	1	PXS-10493-1	Nozzle Insulator
4	1	PXS-121312	Hex Hd Scr 1 1/2" & Nut 1/2"-13
5	1	PXT-9967-10	Nozzle Body Roll Pin
6	1	CWO-8052	Nozzle Body
*7	1	PXS-10125_	Contact Tip (Specify Wire Size*)
8	1	PXS-10138	Flux Cone Plug (Insulator)
9	1	PXT-9078-1	Thumb Screw
10	1	PXT-9967-30	Flux Cone Roll Pin
11	1	PXT-13835	3/4" x 7" Flux Hose w/Fbr Ins
11A	1	PXT-13835-IN	Fiber Insulator
12	1	BUG-3161-P	Cone Body Assembly
13	1	BUG-3163	Locking Ferrule
14	1	BUG-3164	Flux Cone (Kp2085-1)
15	1	BUG-3165	Retaining Nut

**\*WIRE SIZES AVAILABLE:**

<u>PART NO.</u>	<u>WIRE SIZE</u>
CWO-3690-1/16	1/16" (1.6 mm)
CWO-3690-5/64	5/64" (2.0 mm)
CWO-3690-3/32	3/32" (2.4 mm)
CWO-3690-1/8	1/8" (3.2 mm)
CWO-3690-5/32	5/32" (4.0 mm)

**\*REPLACEMENT CONTACT TIPS AVAILABLE:**

<u>PART NO.</u>	<u>WIRE SIZE</u>
CWO-8048	5/64" (2.0 mm)
CWO-8049	3/32" (2.4 mm)
CWO-8050	1/8" (3.2 mm)
CWO-8051	5/32" (4.0 mm)

PXS-10125XL-7/64	7/64" (2.8 mm)
PXS-10125XL-1/16	1/16" (1.6 mm)

# CWO-3710-\_ SUB ARC GUN ASSEMBLY

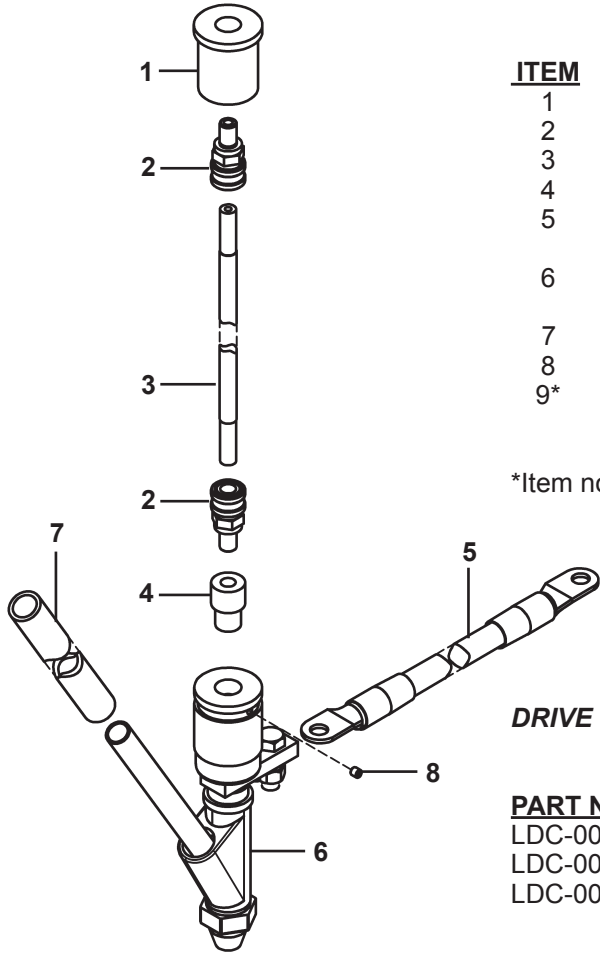

<u>ITEM</u>	<u>QTY</u>	<u>PART NO.</u>	<u>DESCRIPTION</u>
1	1	CWO-1816	Wire Feed Adaptor
2	2	CWO-1817	Bulk Head Connector Qcb
3	1	CWO-3697	Qcc 72" (1829 Mm) Liner
4	1	CWO-3695-1/2	Adaptor K231 1/2"
5	1	CWO-3970-72	Weld Cable 4/0 Assembly 72" (1829 Mm) Lg
6	1	CWO-3690-1/8	Sub-Arc Nozzle 1/8"
	1	CWO-3690-5/32	Sub-Arc Nozzle 5/32"
7	1	CWO-3491-48	Flux Hose 3/4" ID x 1" OD
8	1	FAS-0452	Set Scr 1/4-20 x 1/4
9*	1	BUG-2708	Clamp

\*Item not shown in drawing.

## DRIVE ROLLS

<u>PART NO.</u>	<u>QTY</u>	<u>DESCRIPTION</u>
LDC-0013	1	3/32"-5/32" (2.4-4 mm) Wire Sizes
LDC-0014	1	1/16"-3/32 (1.6-2.4 mm) Wire Sizes
LDC-0015	1	.035"-.052" (.9-1.3 mm) Solid Wire

## ACCESSORIES

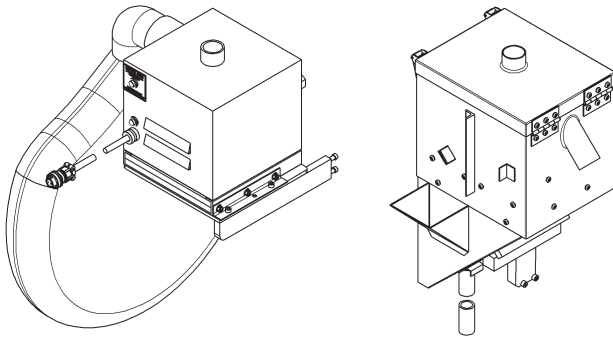

**CWO-2020 Submerged Arc Flux Recovery System**  
Continuously removes and recycles all unused flux.

## 3-JAW EXPANDABLE CHUCKS

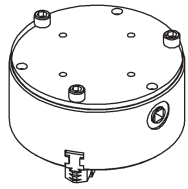

**CWO-3660**

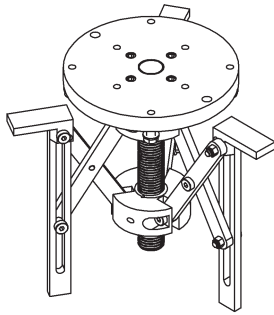

**CWO-3661**

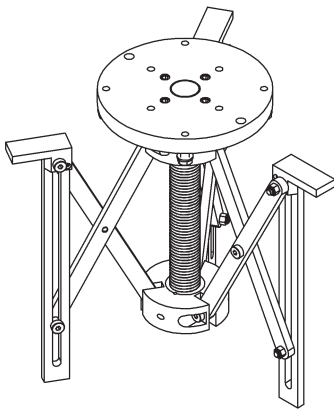

**CWO-3662**

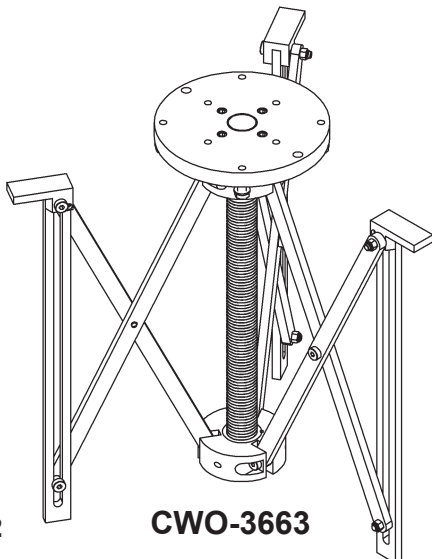

**CWO-3663**

### 3-Jaw Expandable Chucks

Mounts and automatically centers the Circle Welder on nozzles with or without flanges. As shown below.

PART NO.	FOR NOZZLE I.D.'S	WEIGHT
CWO-3660	2"-8" (51-204 mm)	68 lbs. (31 kg)
CWO-3661	8"-16" (204-405 mm)	36 lbs. (16 kg)
CWO-3362	10"-24" (255-610 mm)	51 lbs. (23 kg)
CWO-3663	15.75"-47.25" (400-1200 mm)	64 lbs. (29 kg)

Max. nozzle height is 25" (635 mm)

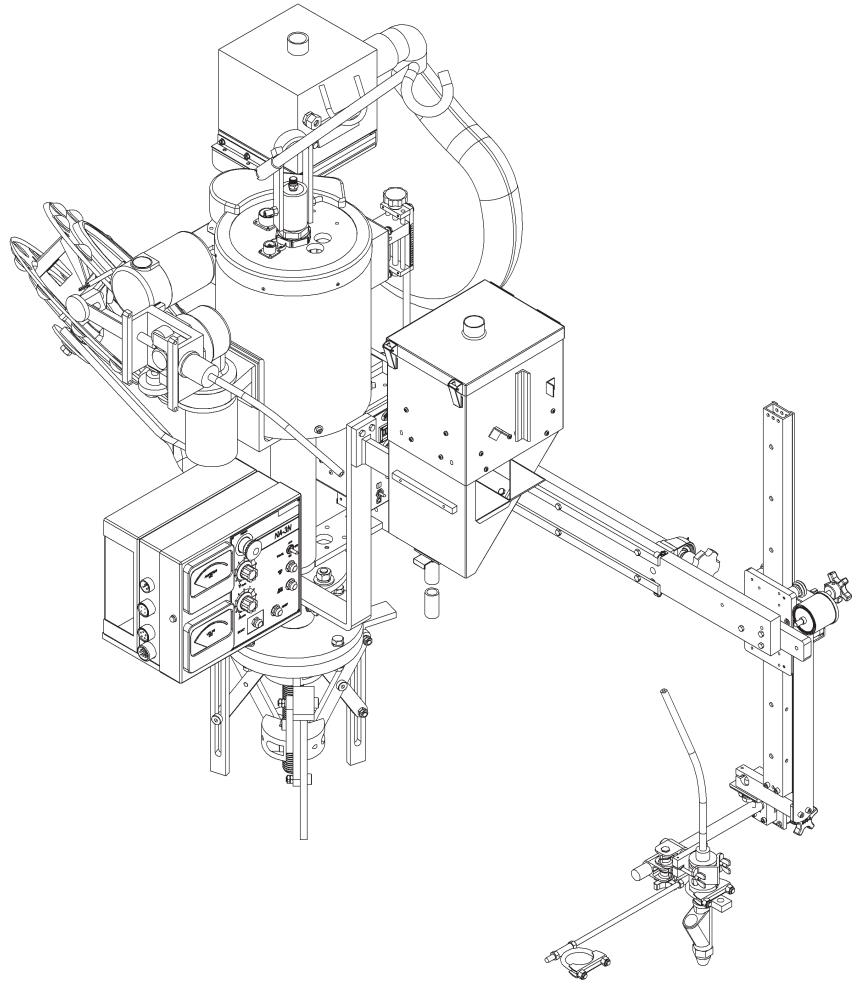

#### Options:

CWO-2020 Flux Recovery System 120V

CWO-2025 Flux Recovery System 240V

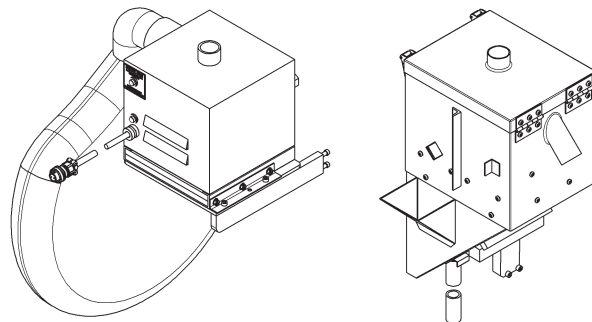



**OPTIONAL 2-AXIS MOTORIZED RACKING EQUIPMENT / CWP-3350 /  
EXPLODED VIEW / PARTS LIST**

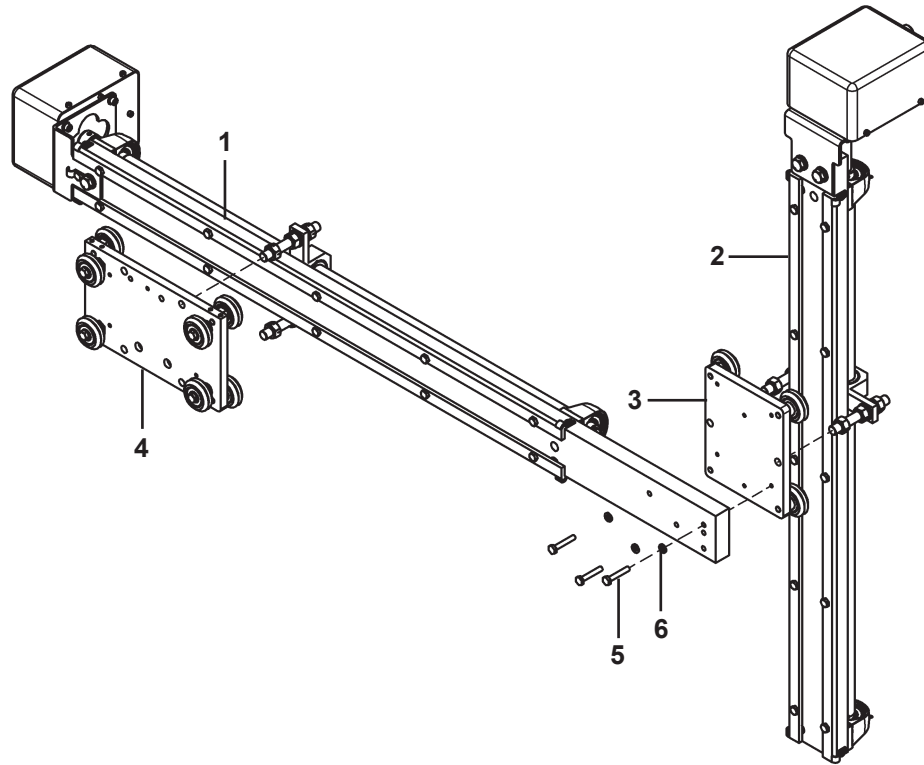

<u>ITEM</u>	<u>QTY</u>	<u>PART NO.</u>	<u>DESCRIPTION</u>
1	1	CWP-3351	Motorized Horiz. Heavy Duty Rack Assembly
2	1	CWP-3352	Motorized Vertical Heavy Duty Rack Assembly
3	1	CWP-3360	Vertical Racker for Heavy Duty
4	1	CWP-3363	Horizontal Racker for Heavy Duty
5	3	FAS-2353	Hex Hd Cap Scr 1/4-20 x 1-1/2
6	3	WAS-0243	1/4" Split Lock Washer
*7	2	CWO-3976	Power Racker Cable

\*Not shown in drawing

# OPTIONAL RACKING MOTORIZED RACKING / CWP-3351 / EXPLODED VIEW / PARTS LIST

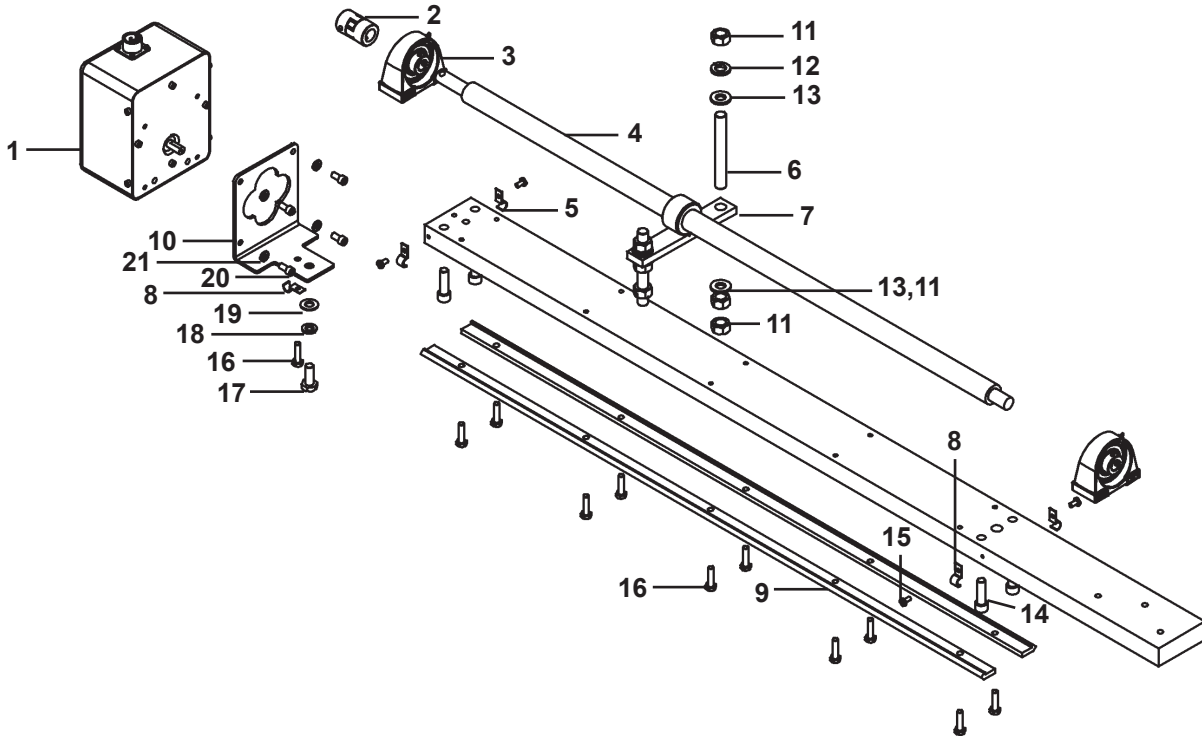

<u>ITEM</u>	<u>QTY</u>	<u>PART NO.</u>	<u>DESCRIPTION</u>
1	1	CWP-3355	Hvy Duty Rack 150:1 No Mounting Bracket
2	1	CWO-5933	Jaw Coupling 3/8" & 5/8" Bores With Spider
3	2	CWO-5565	5/8" Pillow Block
4	1	CWP-3354	Screw for Mtrzd Hrzd Hvy Duty Rack
5	1	CWP-3353	Mtrzd Hrzd Slide Hvy Duty Rack
6	2	CWP-3362	Stud 1/2-13 All Thread
7	1	CWO-3865	1"-6 Acme Nut and Bar Assembly
8	5	CWO-9038	Hold Down Clip
9	2	CWO-9065	T-3 Track 36" Lg
10	1	CWP-3356	Horiz P.M. Motor Bracket #970 Mod
11	6	FAS-1301	Hex Nut 1/2-13
12	2	WAS-0281	1/2 Split Lock Washer Zinc Plated
13	4	WAS-0280	1/2 SAE Flat
14	4	FAS-2591-SS	Soc Hd Cap Scr 3/8-16 x 1-1/4 Stainless Steel
15	4	FAS-1444-SS	Phil Pan Hd Scr 10/32 x 3/8" Stainless Steel
16	10	FAS-0359-SS	Hex Hd Cap Scr 1/4-20 x 1" Stainless Steel
17	1	FAS-0399	Hex Hd Cap Scr 3/8-16 x 1"
18	1	WAS-0262	3/8" Split Lock Washer Zinc Plated
19	1	WAS-0260	3/8 Washer Zinc Plated
20	4	FAS-0555	Soc Hd Cap Scr 1/4-20 x 1/2
21	4	WAS-0243	1/4" Split Lock Washer Zinc Plated

# OPTIONAL MOTORIZED RACKING EQUIPMENT/PRS-1100/EXPLODED VIEW/ WIRING DIAGRAM

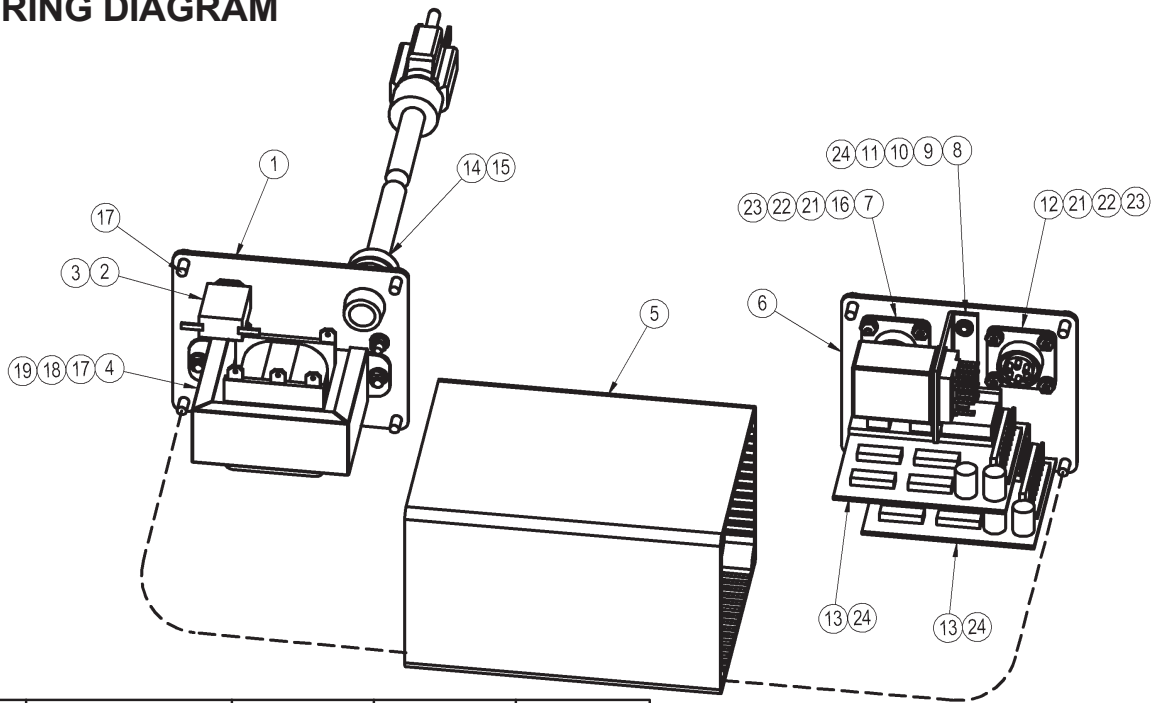

ITEM	DESCRIPTION	PRS-1091	PRS-1093	PRS-1095
		120 VAC PART NO	240 VAC PART NO	42 VAC PART NO
T	Transformer	BUG-5001	BUG-5002	BUG-5003
CB	Circuit Breaker	BUG-2923	BUG-2952	BUG-2933
VT	Volt Trap	BUG-1393	BUG-1563	BUG-1393
PC	Power Cord	BUG-9445	GOF-3115	BUG-9442
R	Relay	BUG-1383	BUG-1551	BUG-9636

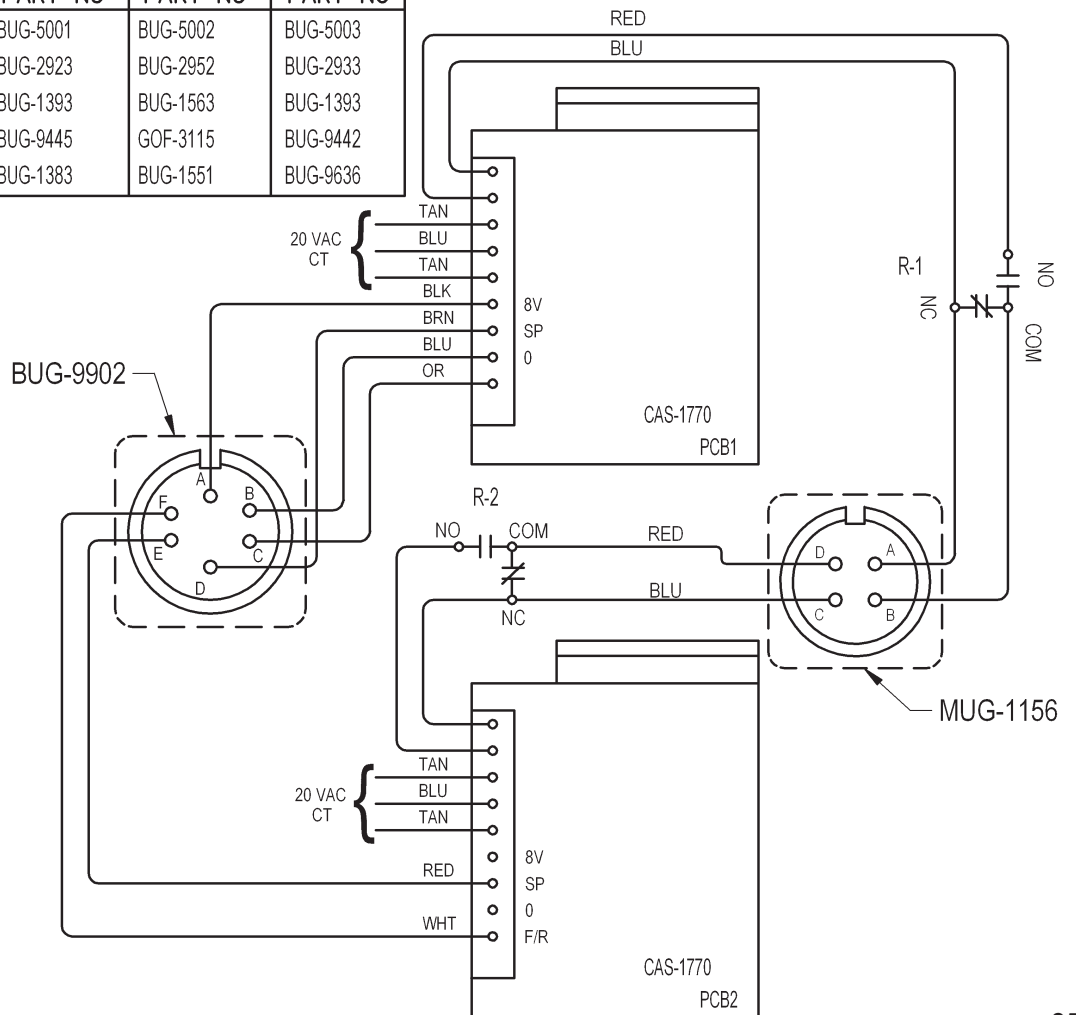
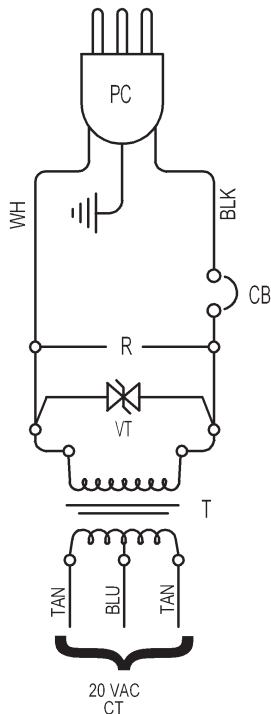

## OPTIONAL MOTORIZED RACKING EQUIPMENT/PRS-1100/PARTS LIST

ITEM	COMPONENT ITEM	DESCRIPTION	120VAC	240VAC	42VAC
1	PRS-1111	Input End Panel	1		
2	BUG-2923	.7 Amp Circuit Breaker	1		
	BUG-2952	.5 Amp Circuit Breaker		1	
	BUG-2933	2 Amp Circuit Breaker			1
3	BUG-2924	"Reset Seal, Transparent"	1		
4	BUG-5001	Transformer 115VAC	1		
	BUG-5002	Transformer 240VAC		1	
	BUG-5003	Transformer 42VAC			1
5	PRS-1110	Enclosure	1		
6	PRS-1112	Output End Panel	1		
7	MUG-1156	Panel Connector, 4-T, F	1		
8	BUG-1404	Relay Bracket	1		
9	BUG-1411	Hold Down Spring	1		
10	BUG-1384	Relay Socket & Spring	1		
11	BUG-1383	Relay, 4Pdt, 3A 120V, Plug In	1		
	BUG-1551	Relay 3A, 240VAC		1	
	BUG-9636	Relay 48VAC			1
12	BUG-9902	Panel Connector, 6-T, F	1		
13	CAS-1770	Speed Control (Iron Rotor)	2		
14	BUG-9446	Cord Grip	1		
15	BUG-9445	Power Cord (120VAC Shown)	1		1
	GOF-3115	Line Cord 240VAC		1	
16	BUG-9628	Cap & Chain Assembly	1		
17	FAS-0124	8/32 x 3/8 Pan Hd, Di-Chrome	10		
18	FAS-1320	Hex Nut 8-32	3		
19	WAS-0221	#8 Internal Star Lockwasher	3		
20	SCW WTE 0514	#8-32 x 3/8" Pan Head, Zinc	1		
21	FAS-0204	Rnd Hd Slit Scr 4-40 x 3/8 Zinc	8		
22	FAS-1305	Hex Nut 4-40	8		
23	WAS-0201	#4 Internal Star Lockwasher	8		
24	FAS-0112	Pan Hd Slit 6-32 x 1/4 Black	6		
N/S	SFX-1292	Bumper, Cylindrical .14 x .50"	4		

# OPTIONAL MOTORIZED RACKING EQUIPMENT/ PRS-1075 / WIRING DIAGRAM

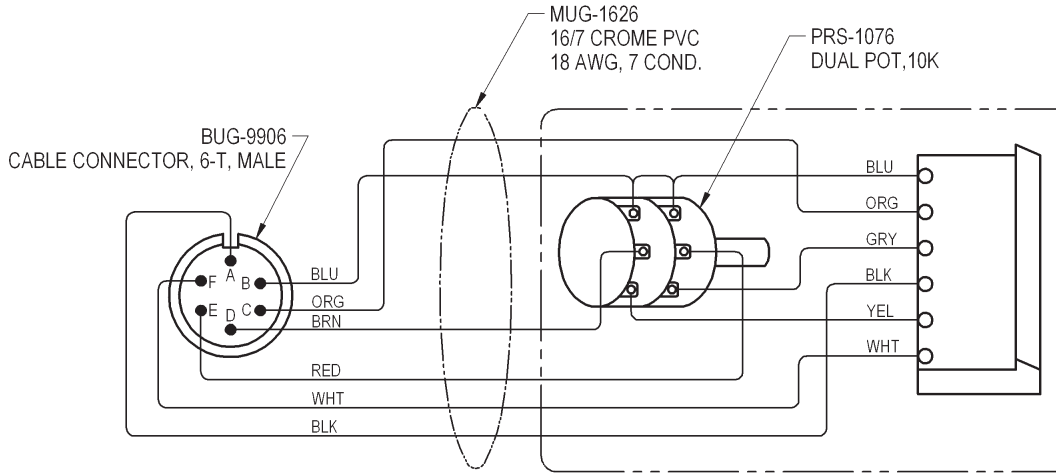
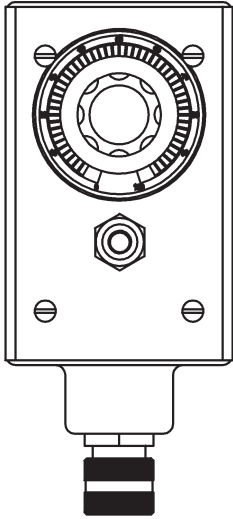

## PREVENTIVE MAINTENANCE / CW-18 CIRCLE WELDER

**IMPORTANT:** Make sure the input power at the power source is turned off and the 50' weld cable is disconnected from the circle welder prior to working inside the circle welder.

### AFTER DAILY USE:

#### Refer to CW-18 Exploded View & Parts List. (Pg. 12-13)

##### Large Horizontal Racker Item #3:

Inspect wheels and remove all dirt, grease, weld spatter and rust. Adjust wheels for snug fit and smooth operation. Lubricate racker pinion and wheels with a dry teflon or graphite spray lubricant.

##### Racking System Item #11:

Inspect gear rack, hardened ways and wheels, remove all dirt, grease, weld spatter and rust. Check hardened ways for nicks and replace if necessary. Lubricate with a dry teflon or graphite spray lubricant. Adjust wheels for snug fit and smooth operation. Lubricate racker pinion with a dry teflon or graphite spray lubricant.

##### Slide Bar Mounting Assembly Item #24:

Inspect hardened ways remove all dirt, grease and weld spatter. Check hardened ways for nicks and replace if necessary. Lubricate with a dry teflon or graphite spray lubricant.

#### Refer to CW-18 Electrical Component Chart. (Pg. 15)

##### CW-18 Collector Item #3:

Inspect cable connector to make sure threads are not stripped and that the connector is not cracked. Ensure that the connector is fastened properly to the large aluminum gear item #34 on the CW-18 Exploded View Parts List.

##### Control Cables:

For all cables leading to CWO-1805 Control box, inspect cable connector to make sure threads are not stripped and that the connector is not cracked. Check the cable for cuts, missing insulation and burn spots, replace if necessary.

### EVERY SIX MONTHS:

#### Refer to CW-18 Exploded View & Parts List. (Pg. 12-13)

##### 7" Cam Assembly Item #14:

Inspect the slide rails and the cam pinion. Remove all dirt, grease and weld spatter. Do not grease slide rails or cam pinion. Lubricate with a dry teflon or graphite spray lubricant. Replace cam pinion if excessively worn. Tighten all fasteners as needed.

##### Wire Reel Assembly Item #20:

Periodically coat the wire wheel shaft with a thin layer of grease as needed. Inspect the shoe assembly and replace if excessively worn.

##### P.M. Motor Assembly Item #21:

Do not grease this pinion. Inspect the drive pinion. Remove all dirt, grease and weld spatter. Lubricate with a dry teflon or graphite spray lubricant. Replace pinion if excessively worn. Check set screw and tighten if necessary. Adjust motor assembly using the four adjustable mounting fasteners so that proper gear mesh is achieved between the aluminum gear item #34 and the motor drive pinion.

##### Aluminum Gear Item #34:

Do not grease this gear. Inspect gear teeth remove all dirt, grease and weld spatter. Lubricate with a dry teflon or graphite spray lubricant. Replace gear if excessively worn.

## **PREVENTATIVE MAINTENANCE / CW-18 CIRCLE WELDER, CONT'D.**

### **Refer to CW-18 Electrical Component Chart. (Pg. 15)**

#### Wire Feeder Assembly Item #1:

Check brushes for wear. Brushes should be replaced when their length is less than 1/4 inch. Replace strain relief on wire if pulled out of motor housing.

#### Brush Holder & Support Item #4:

Inspect brush holder. Make sure constant tension is being applied on the brushes. Brushes should move freely within the brush holder. Check brushes for arc build-up. If brushes are pitted they will need replaced. Remove the brushes and sand them to ensure a smooth contact surface. Make sure all fasteners are tight.

#### Wire Feed Control Item #6:

Open control box, use an air hose to blow out dust and dirt. Check all wires for breaks and replace if necessary. Check all electrical connectors and plugs. If an electrical component fails refer to NA-3 Wire Feeder Control electrical component chart for replacement parts or return for service.

#### Small Brush Retainer Assembly Item #7:

Inspect black brush holders for cracks and replace if needed. Check and make sure all wires are soldered properly to the holders. Replace the brushes when their length is less than 1/2 inch long. Remove the brushes and sand them to ensure a smooth contact surface. Make sure all fasteners are tight.

#### Terminal Block Item #8:

Inspect the plastic terminal strip and make sure it is not cracked, replace if necessary. Make sure all terminal connections are tight. Make sure all ground wires are connected to the mounting screws of the terminal strip.

#### Rotation Control Item #12:

Open control box use an air hose to blow out dust and dirt. Check all wires for breaks and replace if necessary. Check all electrical connectors and plugs. If an electrical component fails refer to CWO-6210-CW18 Rotation Control electrical component chart for replacement parts or return for service.

## **EVERY TWELVE MONTHS:**

### **Refer to CW-18 Exploded View & Parts List. (Pg. 12-13)**

#### Transmission 5:1 Assembly Item #18:

Inspect for excessive wear and tear. Keep the transmission assembly clean and lubricate with Lubriplate #630-AA.

#### P.M. Motor Assembly Item #21:

Bodine gear motor lubrication. Fill gear motor to oil level indicator with worm gear oil conforming to AGMA#5EP compounded (SAE#90) oil or Bodine lubricant (#L-23). Do not overfill.

#### 2" Bearing With Fasteners Item #22:

Do not grease the bearing, it is greased for life by the manufacturer. If the grease fitting has not been removed and plugged we suggest that you do so now. Earlier models may not have been plugged at time of assembly.

#### Wire Feeder Assembly Item #36:

Apply graphite grease to the gear teeth. Inspect the drive roll portion of the assembly, clean as necessary. Do not use solvents on the idle roll because it may wash the lubricant out of the bearings. Do not apply grease to the drive rolls.

## **PREVENTATIVE MAINTENANCE / CW-18 CIRCLE WELDER, CONT'D.**

### **Refer to CW-18 Exploded View & Parts List. (Pg. 12-13)**

#### CW-18 Collector Item #3:

The collector ring should be sanded once a year. If the collector ring is pitted too badly it should be replaced. Inspect all wires coming out of the collector ring for cut or missing insulation. All wires should be fastened to the center shaft with a nylon cable tie. Tighten four set screws if needed.

#### Weld Cable Inlet 4/0 Item #10:

Ensure that the cable is fastened tightly to the collector ring. Inspect the cable for cut or missing insulation. Make sure the micarta insulation tube on the cable is in good condition. Replace the cable if necessary.

#### Control Cables :

For all cables leading to the CWO-1805 Control Box, inspect the cable for cuts or missing insulation. Ensure that the elbow connector is not damaged. Ensure that all terminal ends are snug. Replace cable if necessary.

#### Solenoid Adaptor Kit (Optional):

Inspect for damage. Replace if necessary.



# WARRANTY

## Limited 3-Year Warranty\*

Model \_\_\_\_\_  
Serial No. \_\_\_\_\_  
Date Purchased: \_\_\_\_\_  
Where Purchased: \_\_\_\_\_

For a period ending one (1) year from the date of invoice, Manufacturer warrants that any new machine or part is free from defects in materials and workmanship and Manufacturer agrees to repair or replace at its option, any defective part or machine. HOWEVER, if the invoiced customer registers the Product Warranty by returning the Warranty Registration Card supplied with the product within 90 days of the invoice date, or by registering on-line at [www.bugo.com](http://www.bugo.com), Manufacturer will extend the warranty period an additional two (2) years which will provide three (3) total years from the date of original invoice to customer. This warranty does not apply to machines which, after Manufacturer's inspection are determined by Manufacturer to have been damaged due to neglect, abuse, overloading, accident or improper usage. All shipping and handling charges will be paid by the customer.

The foregoing express warranty is exclusive and Manufacturer makes no representation or warranty (either express or implied) other than as set forth expressly in the preceding sentence. Specifically, Manufacturer makes no express or implied warranty of merchantability or fitness for any particular purpose with respect to any goods. Manufacturer shall not be subject to any other obligations or liabilities whatsoever with respect to machines or parts furnished by Manufacturer.

Manufacturer shall not in any event be liable to Distributor or any customer for any loss of profits, incidental or consequential damages or special damages of any kind. Distributor's or customer's sole and exclusive remedy against Manufacturer for any breach of warranty, negligence, strict liability or any other claim relating to goods delivered pursuant hereto shall be for repair or replacement (at Manufacturer's option) of the machines or parts affected by such breach.

### Distributor's Warranty:

In no event shall Manufacturer be liable to Distributor or to any customer thereof for any warranties, representations or promises, express or implied, extended by Distributor without the advance written consent of Manufacturer, including but not limited to any and all warranties of merchantability or fitness for a particular purpose and all warranties, representations or promises which exceed or are different from the express limited warranty set forth above. Distributor agrees to indemnify and hold Manufacturer harmless from any claim by a customer based upon any express or implied warranty by Distributor which exceeds or differs from Manufacturer's express limited warranty set forth above.

### HOW TO OBTAIN SERVICE:

***If you think this machine is not operating properly, re-read the instruction manual carefully, then call your Authorized BUG-O dealer/distributor. If they cannot give you the necessary service, write or phone us to tell us exactly what difficulty you have experienced. BE SURE to mention the MODEL and SERIAL numbers.***

\*Bug-O System's warranty applies to Bug-O components only. Where other brands of power sources, wire feeders or sub components are a part of Bug-O Equipment, please refer to that specific Manufacturer's manual for warranty specifications on their components.