

# INSTRUCTIONS AND PARTS MANUAL

## UNIVERSAL BUG-O-MATIC WITH AUTOMATED HEIGHT CONTROL (AHC)

**BUG-6550 110 VAC**

**BUG-6552 220 VAC**

**BUG-6554 42 VAC**

Please record your equipment identification information below for future reference. This information can be found on your machine nameplate.

Model Number \_\_\_\_\_

Serial Number \_\_\_\_\_

Date of Purchase \_\_\_\_\_

Whenever you request replacement parts or information on this equipment, always supply the information you have recorded above.

LIT-UBOM-AHC-IPM-0424

Bug-O Systems is committed to empowering our customers by providing operator controlled mechanized solutions for their welding, cutting and custom applications.



**BUG-O SYSTEMS**

A DIVISION OF WELD TOOLING CORPORATION



280 TECHNOLOGY DRIVE CANONSBURG, PENNSYLVANIA 15317 USA  
PHONE: 412-331-1776 <https://www.bugo.com> FAX: 412-331-0383

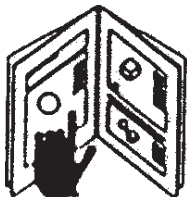
# SAFETY

**PROTECT YOURSELF AND OTHERS FROM SERIOUS INJURY OR DEATH. KEEP CHILDREN AWAY. BE SURE THAT ALL INSTALLATION, OPERATION, MAINTENANCE AND REPAIR PROCEDURES ARE PERFORMED ONLY BY QUALIFIED INDIVIDUALS.**



## **ELECTRIC SHOCK CAN KILL.**

- 1) The equipment is not waterproof. Using the unit in a wet environment may result in serious injury. Do not touch equipment when wet or standing in a wet location.
- 2) The unused connectors have power on them. Always keep the unused connectors covered with the supplied protective panels. Operation of the machine without the protective panels may result in injury.
- 3) Never open the equipment without first unplugging the power cord or serious injury may result.
- 4) Verify the customer supplied power connections are made in accordance with all applicable local and national electrical safety codes. If none exist, use International Electric Code (IEC) 950.
- 5) Never remove or bypass the equipment power cord ground. Verify the equipment is grounded in accordance with all applicable local and national electrical safety codes. In none exist, use International Electric Code (IEC) 950.



## **READ INSTRUCTIONS.**

Read the instruction manual before installing and using the equipment.



## **EQUIPMENT DAMAGE POSSIBLE.**

- 1) Do not plug in the power cord with out first verifying the equipment is OFF and the cord input voltage is the same as required by the machine or serious damage may result.
- 2) Always verify both the pinion and wheels are fully engaged before applying power or equipment damage may occur.
- 3) Do not leave the equipment unattended.
- 4) Remove from the work site and store in a safe location when not in use.



## **FALLING EQUIPMENT can cause serious personal injury and equipment damage.**

Faulty or careless user installation is possible. As a result, never stand or walk underneath equipment.



## **MOVING PARTS can cause serious injury.**

- 1) Never try to stop the pinion from moving except by removing power or by using the STOP control.
- 2) Do not remove any protective panels, covers or guards and operate equipment.

## HIGH FREQUENCY WARNINGS

**SPECIAL PRECAUTIONS ARE REQUIRED WHEN USING PLASMA, TIG OR ANY WELDING PROCESS THAT USES HIGH FREQUENCY TO STRIKE AN ARC.**



**WARNING:** HIGH FREQUENCY CAN EFFECT MACHINE OPERATION AND THEREFORE, WELD QUALITY.

Read the precautions below before installing and using the equipment.

### PRECAUTIONS:

- 1) Some plasma or welding cables are strong sources of high frequency interference. NEVER lay a plasma or welding cable across the controls of the machine.
- 2) Always physically separate the plasma or welding cable leads from the machine cables. For example, the plasma or welding cable leads should NEVER be bundled with a pendant cable or the machine power cord. Maximize the separation between any machine cables and the plasma or welding cables.
- 3) Strictly follow the grounding procedures specified for the plasma or welding unit. NOTE: Some plasma and welding units produce exceptionally large amounts of high frequency noise. They may require a grounding rod be driven into the earth within six feet (2 meters) of the plasma or welding unit to become compatible with an automatic cutting or welding process.
- 4) If the high frequency is produced using a spark gap, adjust the points so the gap is as small as possible. The larger the gap, the higher the voltage and the higher the interference.
- 5) Some plasma or welding units will inject high frequency interference into the AC power line. Use separate power line branches whenever possible to power the plasma or welding source and the machine. Do not plug them into the same outlet box.
- 6) High frequency noise may enter the machine through the plasma or welding supply remote contactor leads. Some plasma and welding sources can produce noise spikes of up to several thousand volts. These sources are not compatible with automated cutting and welding equipment. It is recommended that the remote contactor leads on these plasma or welding sources not be connected to the machine. An alternate solution is to purchase a separate remote contactor isolation box.

# UNIVERSAL BUG-O-MATIC WITH AHC

## INSTRUCTIONS AND PARTS MANUAL

### TABLE OF CONTENTS

Introduction .....	5
Technical Data .....	5
Features .....	5
Detailed Setup .....	6
Power Source .....	7
Pendant Control.....	8
Automated Height Control .....	9
Centering The Cross Arm .....	9
Operation.....	9
<b>Exploded Views &amp; Parts Lists</b>	
BUG-6550 Universal Bug-O-Matic With AHC .....	10
BUG-5980 Drive Unit.....	11
BUG-5990 BUG-5992 BUG-5994 Cover Assembly.....	12
BUG-5715 Base Assembly .....	13
BUG-5725 Cross Drive Assembly.....	13
CAS-1555 CAS Electronics Box.....	14
BUG-5755 Pendant Control.....	15
CAS-1500 Height Slide Assembly .....	16
CAS-1550 Hall Effects Current Sensor.....	17
WPD-1150 Cross Arm.....	18
BUG-5975 Cable Anchor .....	19
<b>Wiring Diagrams &amp; Electrical Component Charts</b>	
BUG-598X Drive Unit Wiring Diagram.....	20
BUG-598X Drive Unit Electrical Component Chart.....	21
CAS-1555 CAS Electronics .....	22
BUG-5755 Control Pendant.....	23
Rail Options .....	24
Carriage Options .....	28
Service Procedure: Installing The Cross Arm .....	31
Spare Parts Lists .....	33
EU Declaration of Conformity .....	35
Warranty .....	36

# INTRODUCTION

The Universal Bug-O-Matic with Automated Height Control (AHC) improves weld quality through automation in three planes of movement. The powerful drive motor maintains a constant travel speed during welding; the built-in precision oscillator provides a uniform weave pattern; and the height controller maintains a constant tip to work piece distance. This versatile machine is compatible with a variety of BUG-O carriages and rails to suit your welding needs.

## TECHNICAL DATA

Power Requirements	BUG-6550 120VAC/50-60/1 BUG-6552 240VAC/50-60/1 BUG-6554 42VAC/50-60/1
Linear Speed	3-70 ipm (75-1750 mm/m)
Weave Speed	4-100 ipm (100-2500 mm/m)
Dwell Times	0-3 seconds left 0-3 seconds right
Weave Width	0.1-2.0" (2.5-50 mm)
Steering	2" (50 mm) left & right of center 4" (100 mm) total
Load Capacity	30 lbs. (14 kg)
Net Weight	22 lbs. (10 kg)

## FEATURES

- Automated Height Control (AHC) maintains constant weld tip to work piece distance.
- Remote control allows operator to start/ stop weld and steer welding tip from up to 10 ft. away.
- Lockable digital dials for key parameters prevent accidental adjustment and display numeric value for setting, allowing repeatable setup of parameters.
- Proven rack and pinion drive provides accurate travel speed.
- Independent left and right dwell controls.

The machine can be mounted on MPD-1065 Releasable Carriage, MPD-1055 18" Carriage, FMD-1022 Carriage for Hi-Flex rail or BUG-5960 for BRR Carriage. By simply changing the carriage, the machine will run on any BUG-O rail - Aluminum Rigid, Semi-Flex, Bent Rigid or Hi-Flex Rail . The chart below shows which types of rail are compatible with each carriage. See pages 24-30 for details.

CARRIAGES	RAILS						
	Aluminum Rigid Rail ARR-1080 & ARR-1085	Bent Rigid Rail BRR-1180 & BRR-1210	Hi-Flex Rail FMD-1050	Semi-Flex Rail AFR-3000	PSR Ring Rail PSR-2000-XX	Piper Flex Rail PSR-2200	
BUG-5960 BRR Carriage	X	X		X			
FMD-1022 Hi-Flex Carriage			X				
MPD-1055 18" Carriage	X						
MPD-1065 Releasable Carriage	X			X			
BUG-6550-QC-PSR-CARR Carriage					X	X	

The power Supply transformer is contained inside the unit. Pendant control of all functions is provided, including:

- weave speed and amplitude, and centerline steering,
- left and right dwell time,
- tractor speed and direction,
- weld contact on/off.

## DETAILED SETUP

### 1. Secure the Rail to the Workpiece

The Universal Bug-O-Matic with AHC is designed for use with most BUG-O rails. Descriptions of the various BUG-O rails and their applications are provided on pages 24-27. Select a rail appropriate to your application. Install rail to workpiece.

### 2. Secure the Carriage on the Rail

Select a BUG-O carriage that is compatible with the rail being used. Descriptions of the various BUG-O carriages are provided on pages 28-30. Declutch the drive pinion prior to installing carriage. Verify wheel alignment and adjust wheels as needed, then engage the drive pinion.

### 3. Position and Clamp Welding Gun

Secure welding gun in the all-position clamp located on the end of the height control mechanism. Arrange cables so that they do not interfere with the movement of the machine before securing cables in the cable anchor at the back of the machine.

### 4. Connect Control Cables

The Universal Bug-O-Matic with AHC includes four control cables that must be properly connected for the machine to function.

- A. Connect the Control Pendant (BUG-5755) to the Drive Unit (BUG-5980).
- B. Connect the weld contact outlet, pins A & B, on the Drive Unit (BUG-5980) to the wire feeder contact circuit.
- C. Connect the Height Slide Assembly (CAS-1500) to the CAS Electronics Box (CAS-1555).
- D. Connect the control cable from the Current Sensor (CAS-1550) to the CAS Electronics Box (CAS-1555).

### 5. Install Current Sensor

Connect the Hall Effect Current Sensor “in-line” on welding power source ground cable. The positive lead and the input cable are located on the same side of the enclosure. For a positive electrode, this lead should be connected to the work piece.

### 6. Plug in Universal Bug-O-Matic with AHC

Inspect the power cord before each use. Do not use if damaged. Plug in the machine to a power receptacle of the appropriate voltage.

### 7. Power ON Universal Bug-O-Matic with AHC

**CAUTION: Machine may start moving as soon as it is powered on.**

Use the toggle switch on the back of the drive unit to turn power on and off to the machine. For operator safety, set weld pattern to “NO WEAVE” and tractor to “OFF” before turning on the machine.

### 8. Position Welding Gun

Proper setup of the welding gun is critical to a successful weld. In addition to manually positioning the welding gun within the clamp, the welding gun must also be properly set with respect to three mechanical controls: The cross arm, the height controller and the tractor position.

- A. Cross Arm: The cross arm offers a weave up to 1" (25 mm) left and right, 2" (50 mm) total. Center the cross arm before placing the welding gun over the work area. This will ensure maximum oscillation amplitude. See “Centering the Cross Arm” on page 9.
- B. Height Slide Assembly: The slide assembly has 4" (100 mm) of vertical travel available. For best results, position the slide assembly in the middle of its travel range before setting the welding gun. Use the torch manual jog switch to raise or lower the height controller to the desired height.

NOTE: When installing the Height control slide, the control cable connection must be on the top side of the slide, as shown on page 10.

- C. Tractor position: Use the tractor Forward/Off/Reverse switch to position the Universal Bug-O-Matic with AHC at the start of the weld. The operator can increase or decrease the tractor travel speed at any time using the speed controller.

## DETAILED SETUP, CONT'D.

### 9. Set Weld Parameters

Use the control pendant to set the seven weld parameters.

A. Weave Speed. Controls the travel speed of the cross arm.

B. Weave Amplitude. Controls the width of oscillation, up to 2" (50 mm).

C. Left Dwell time. Controls how long the cross arm pauses on the left edge of the weld (0-3 sec).

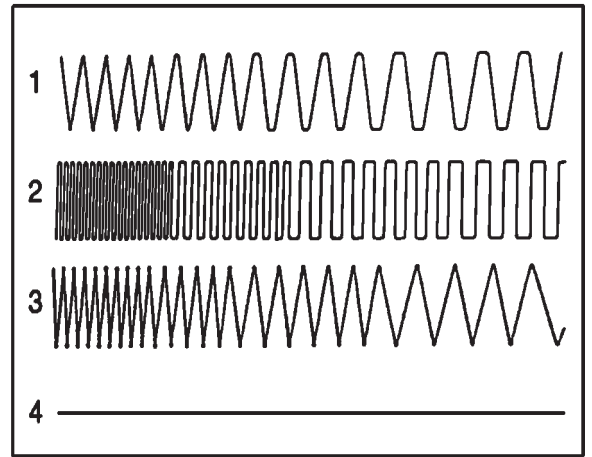
D. Right Dwell time. Controls how long the cross arm pauses on the right edge of the weld (0-3 sec).

E. Current Setpoint. Controls the tip to work piece distance during weld. Set the desired weld current on the pendant and on the welding power source. The automatic height control mechanism will move the weld gun up and down, as needed, to maintain constant current during welding.

F. Travel Speed. Controls the tractor travel speed (3-70 ipm).

G. Weave Mode. Choose one of four modes.

- 1) RUN - In this mode, the drive motor is always on and the tractor travels continuously -- during both weave and dwell. Weave speed and dwell time both affect the weave pattern.
- 2) STEP - The tractor travels only during dwell and stops during the weaver cross stroke. Changing weave speed does not effect the weld pattern-dwell time does.
- 3) TRACTOR STOP ON DWELL - The tractor travels during the weave stroke; the tractor and the weaver stop during dwell.
- 4) NO WEAWE - In this mode oscillation is stopped. Only the tractor is powered. This mode is used for stringer passes.



### 10. Verify Setup and Lock Dials

Before proceeding to weld, take a moment to verify that the machine is setup correctly. With the tractor on, but the arc off, run the machine and verify that it is moving as intended. Check cross arm movement and speed, and tractor travel speed. Verify that the cross arm moves over the full width of the weld. Use the height controller manual jog switch to make sure that enough vertical travel is available.

Once all parameters have been set and verified, lock the dials to prevent accidental changes. Turn the knob counterclockwise (CCW) to unlock, clockwise (CW) to lock.

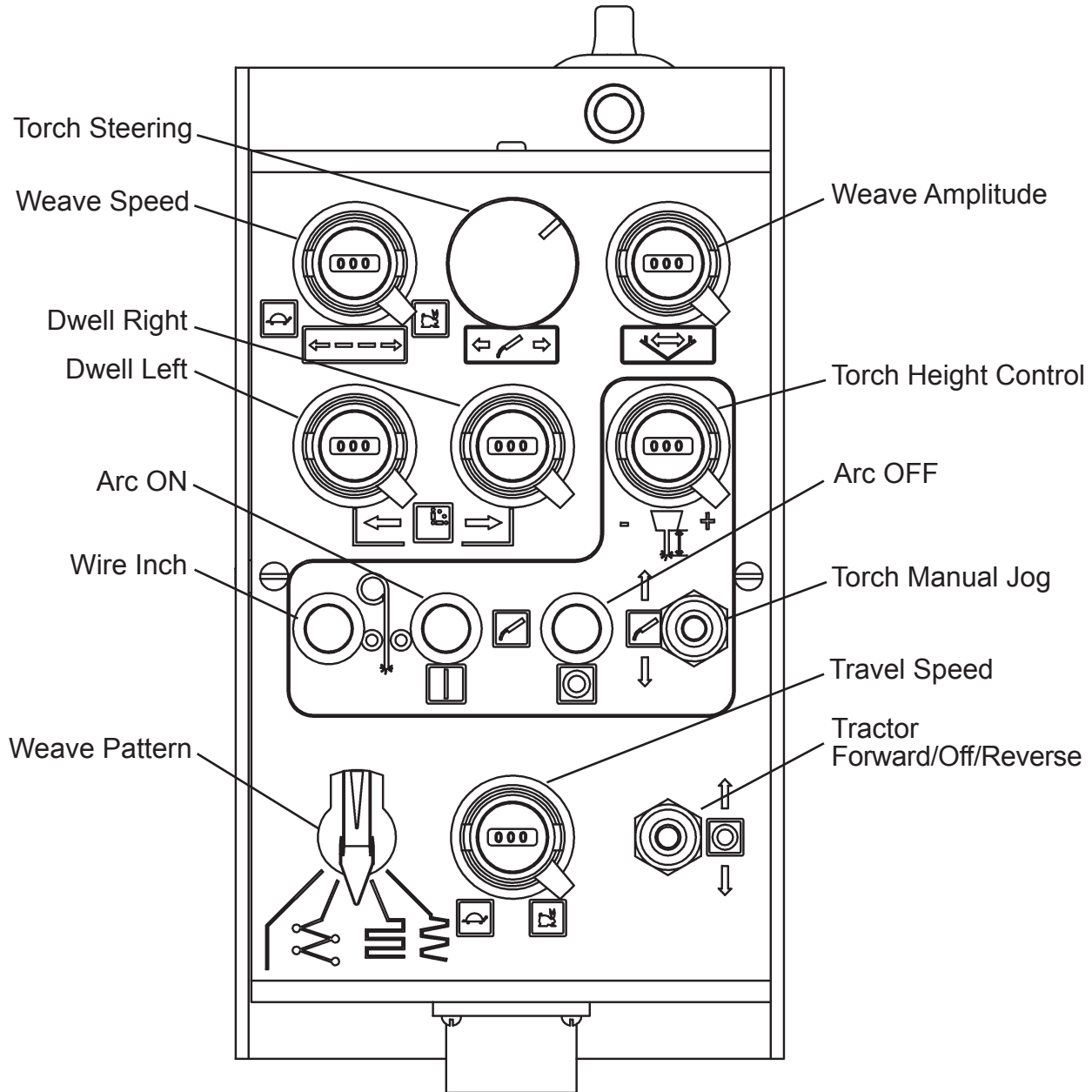
## POWER SOURCE

Use only constant voltage (CV) type power sources with this welding device. If using a multiple process power source, be sure that it is set for constant voltage (CV) output as per the instructions in the power source manual. Set the power source polarity switch properly or connect the electrodes and work leads for the correct electrode polarity.



## PENDANT CONTROL

The Universal Bug-O-Matic with AHC features a remote control pendant which allows the operator to run the machine from up to 10 feet (3 m) away. The pendant can be clamped to the machine handle for easy storage or transport.



The control pendant features lockable digital dials. Each dial can be locked once it is set to the desired value. To lock a dial, rotate the locking lever clockwise until it stops. To unlock a dial, rotate the lever counterclockwise until it clicks. Each dial also indicates a numeric value for its current position. Table 1, on the next page, shows how the dial value relates to the actual value for each setting.



**Table 1: Dial Ratios**

PARAMETER	ACTUAL RANGE	DIAL RANGE	RATIO	
			Dial	Actual
Weave Speed	4-100 in/min 0.1-2.5 m/min	0-300	012	4 in/min 0.1 m/min
Weave Amplitude	0.1-2 in 3-50 mm	0-300	015	0.1 in 2.5 mm
Dwell Time (Left or Right)	0-3 sec	0-999	033	0.1 sec
Height Control	0-500 amps	0-500	050	50 amp
Tractor Speed	3-70 in/min 0.075-1.75 m/min	0-300	012	3 in/min 0.075 m/min

*Table 1 displays the ratio between a dial value and its corresponding measurable value. For example, setting the weave speed dial to 096 results in an actual weave speed of 32in/min.*

## **AUTOMATED HEIGHT CONTROL**

The Universal Bug-O-Matic with AHC features automated height control (AHC), which controls the welding tip to work distance and maintains a constant weld current, or uniform weld penetration. AHC senses the actual weld current, compares this value to the setpoint, and raises or lowers the welding gun accordingly. Controls for the AHC are self contained and its drives are independent from those of the drive unit. AHC features a built-in time delay after the arc is struck, and automatically shuts off when current drops too low (generally below 60 amp). The operator can temporarily override AHC using the manual jog switch while welding. AHC resumes as soon as the jog switch is released. To disable the automated height control, move the Auto/Manual switch on the CAS Electronics Box (CAS-1555) to MANUAL. All BUG-O Automatic Height Controls require a Constant Voltage (CV) Power Source. Consult the factory for your particular application.

NOTE: When installing the Height control slide, the control cable connection must be on the top side of the slide, as shown on page 10.

## **CENTERING THE CROSS ARM**

Verify that the cross arm is centered before clamping the welding gun in place.

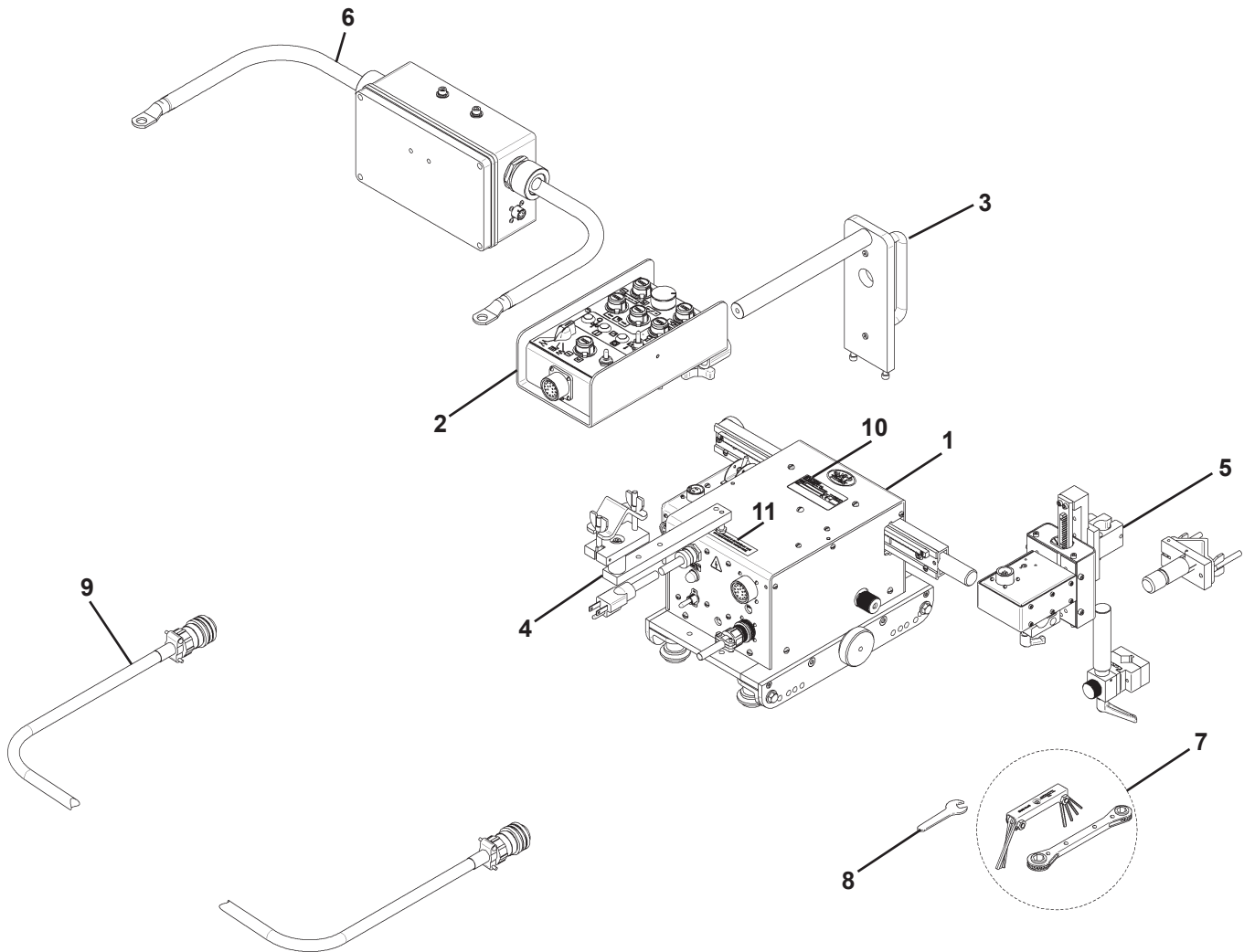
1. Set the weld mode to "NO WEAVE" and turn on the AC power.
2. Turn the Torch Steering knob counterclockwise until it stops.
3. Turn the Torch Steering knob clockwise until it stops. This should be 3 turns.
4. Turn the Torch Steering knob 1 1/2 turns counterclockwise. The cross arm should now be centered.
5. If the cross arm is not centered, refer to the service procedures on pages 31 and 32.

To verify that an adequate range of motion is available, adjust the oscillation amplitude to the desired setting, and change the weld mode. Check that the welding gun moves across the entire weld groove.

## **OPERATION**

1. Setup machine according to the instructions provided on pages 6-7.
2. With weld gun at the start of the weld, depress "Arc On" button and allow puddle build-up.
3. Switch tractor toggle to "Forward".
4. Fine tune welding parameters as needed while welding. Lock dials when finished.
5. At the end of the weld, switch tractor toggle to "Off".
6. Allow for crater fill, then depress "Arc Off" button when finished.

# BUG-6550 UNIVERSAL BUG-O-MATIC WITH AHC / PARTS LIST

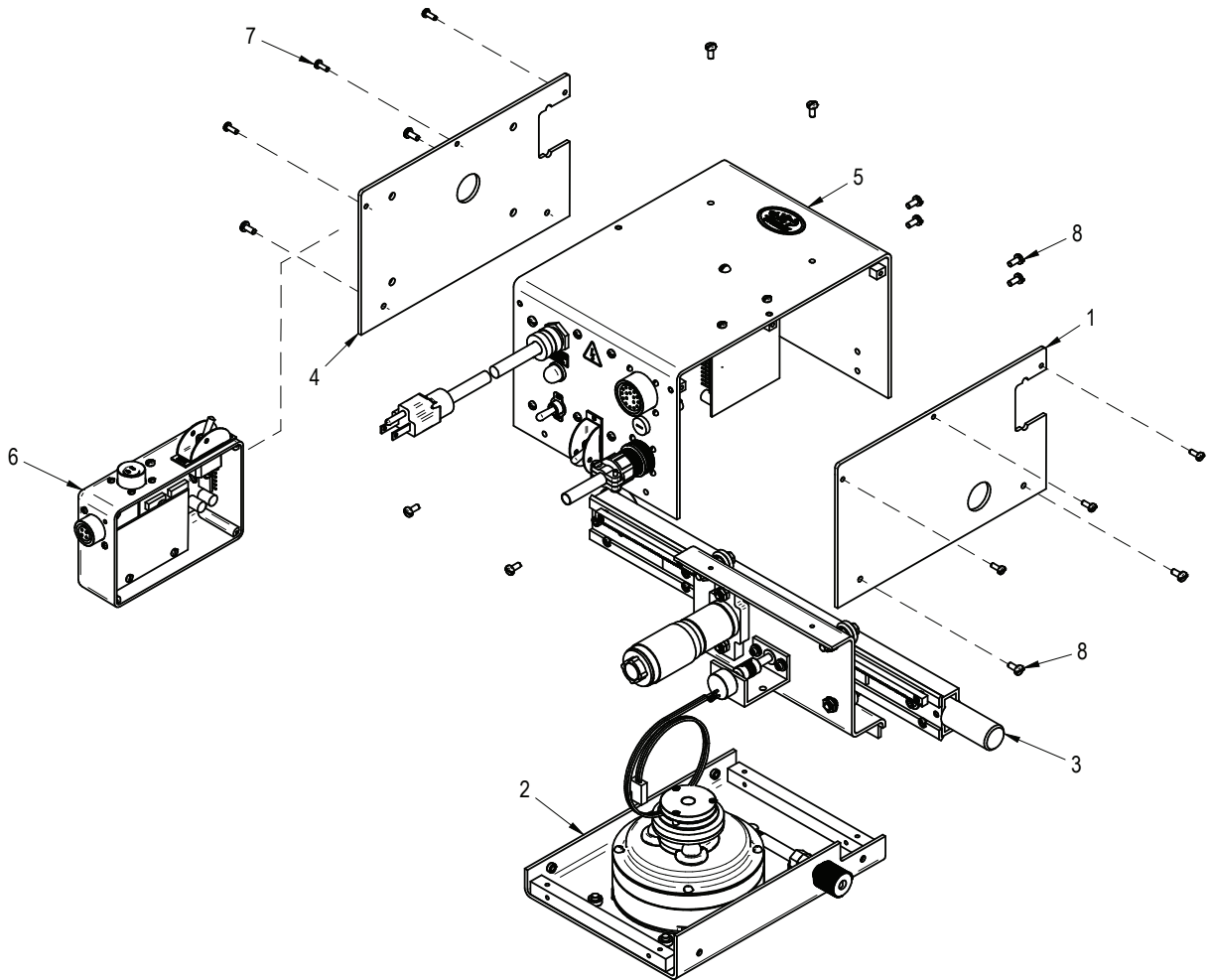


<u>ITEM</u>	<u>QTY</u>	<u>PART NO.</u>	<u>DESCRIPTION</u>
1*	1	BUG-5980	Drive Box, 120V*
2	1	BUG-5755	Control, Pipe Welder
3	1	BUG-5965	Handle Assembly
4	1	BUG-5930	Low Profile Cable Anchor Ass'y
5	1	CAS-1500	Height Slide Ass'y
6	1	CAS-1550	Hall Effect Current Sensor
7	1	BUG-9444	Tool Kit
8	1	BUG-9447	Wrench
9	1	BUG-5551-10-HD	10 FT. Cable Ass'y, HD, Shielded
10	1	100-0427	CE Name Plate, Blk
11	1	BUG-2414	Label, Patent
**	4	FAS-0115	6-32 X 1/2 Pan Head, Zinc
**	4	WAS-0230	#10 SAE Flat

\* The drive unit for the 240V is BUG-5982 and for the 42V is BUG-5984.

\*\*Not shown in drawing

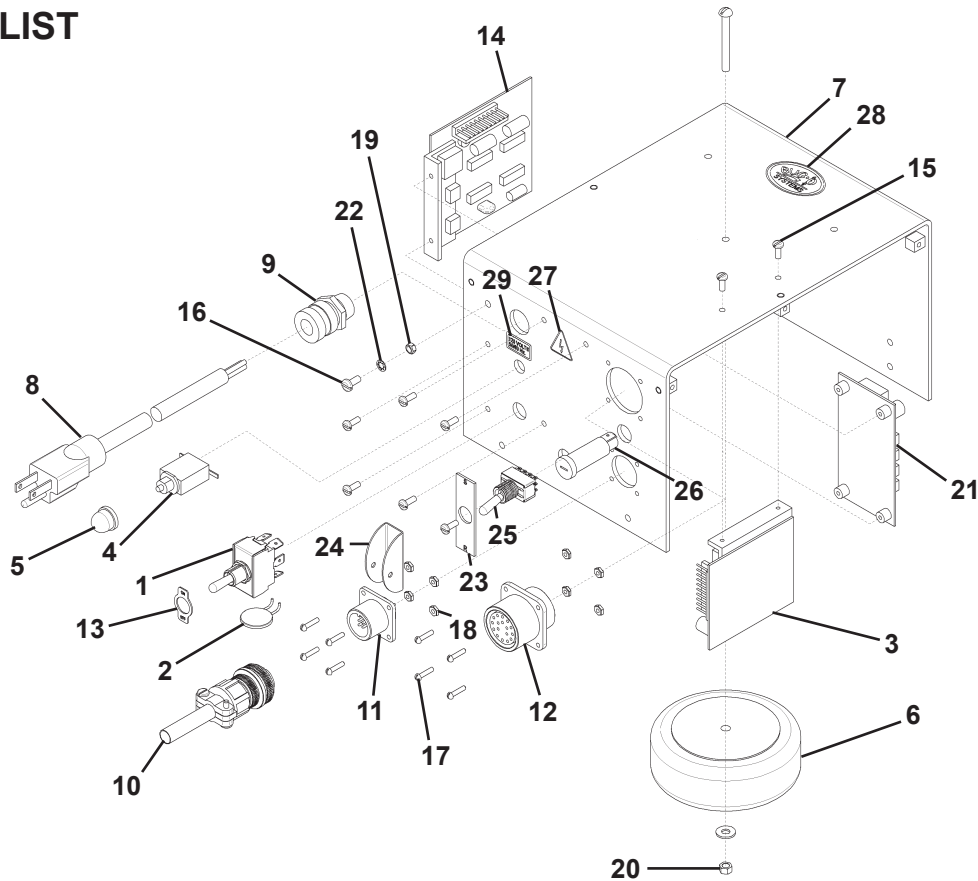
# BUG-5980 DRIVE UNIT / EXPLODED VIEW / PARTS LIST



<u>ITEM</u>	<u>QTY</u>	<u>PART NO.</u>	<u>DESCRIPTION</u>
1	1	BUG-5708	Right Panel
2	1	BUG-5715	Base Assembly
3	1	BUG-5725	Cross Drive Assembly
4	1	BUG-5957	Left Panel
5*	1	BUG-5990	Cover Ass'y, 120V*
6	1	CAS-1555	CAS Electronics Box
7	6	FAS-0114	Screw, 6-32 x 3/8
8	12	FAS-0124	Screw, 8-32 x 3/8

\* Cover Assembly for 240V is BUG-5992, for 42V is BUG-5994

# BUG-5990 BUG-5992 BUG-5994 COVER ASSEMBLY / EXPLODED VIEW / PARTS LIST

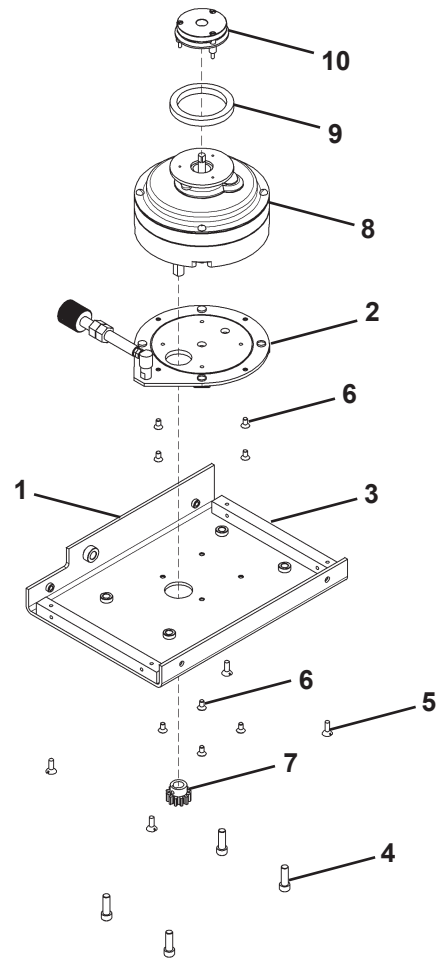


<u>ITEM</u>	<u>QTY</u>	<u>PART NO.</u>	<u>DESCRIPTION</u>
1	1	ARM-2279	Toggle Switch
2*	1	BUG-1393	Volt Trap, 120V
3	1	BUG-1770-UB	Motor Control Board
4*	1	BUG-2923	Circuit Breaker, 0.7 Amp*
5	1	BUG-2924	Reset Button Seal
6*	1	BUG-5218	Transformer, 120V*
7	1	BUG-5721	Anodized Cover Panel
8*	1	BUG-9445	Power Cord*
9	1	BUG-9446	Cord Grip
10	1	BUG-1035	Cable Connector, 4-T
11	1	BUG-1034	Panel Connector, 4-T
12	1	BUG-5527	Panel Connector, 17-T
13	1	BUG-9884	On-Off Switch Plate
14	1	CAS-1770-001	Motor Control Board
15	8	FAS-0114	Screw, Pan Head 6-32 x 3/8
16	1	FAS-0124	Screw, Pan Head 8-32 x 3/8
17	8	FAS-0205	Screw, Round Head 4-40 x 1/2
18	8	FAS-1305	Hex Nut, 4-40
19	1	FAS-1320	Hex Nut, 8-32
20	8	FAS-1330	Hex Nut, 10-24
21	1	PCB-5700	Interconnect Board
22	1	WAS-0221	#8 Int. Star Lock Washer
23	1	BUG-5776	Legend Plate, S/R
24	1	PWS-0149	Switch Guard
25	1	SWT-0503	Switch, Toggle, 4PDT
26	1	FHO-0190	5 x 20mm Fuse Holder
27	1	100-0429	Shock Label
28	1	BUG-2005	Label, Bug-O Systems
29	1	BUG-9234	Label, 120V

\* See Electrical Component Chart on Page 21 for a complete list of voltage specific parts.

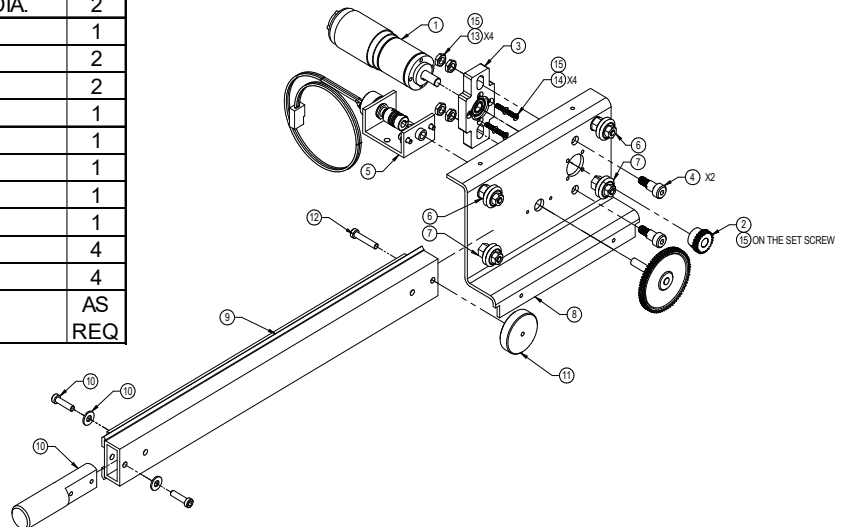
## BUG-5715 BASE ASSEMBLY / EXPLODED VIEW / PARTS LIST

ITEM	QTY	PART NO.	DESCRIPTION
1	1	BUG-5709	Base Plate
2	1	BUG-5716	Clutch Assembly
3	2	BUG-5723	Attachment Bar
4	4	FAS-0557	Screw, Soc Hd Cap, 1/4-20 x 3/4
5	4	FAS-0825	Screw, Flat Hd Slot, 8-32 x 1/2
6	8	FAS-0923	Screw, Flat Hd Soc, 8-32 x 5/16
7	1	GOF-3014	Drive Pinion w/ Key
8	1	MPD-1015	Gear Motor (60:1)
9	1	WPD-1013	Gasket, Rubber Ring
10	1	WPD-1045	Brake Assembly

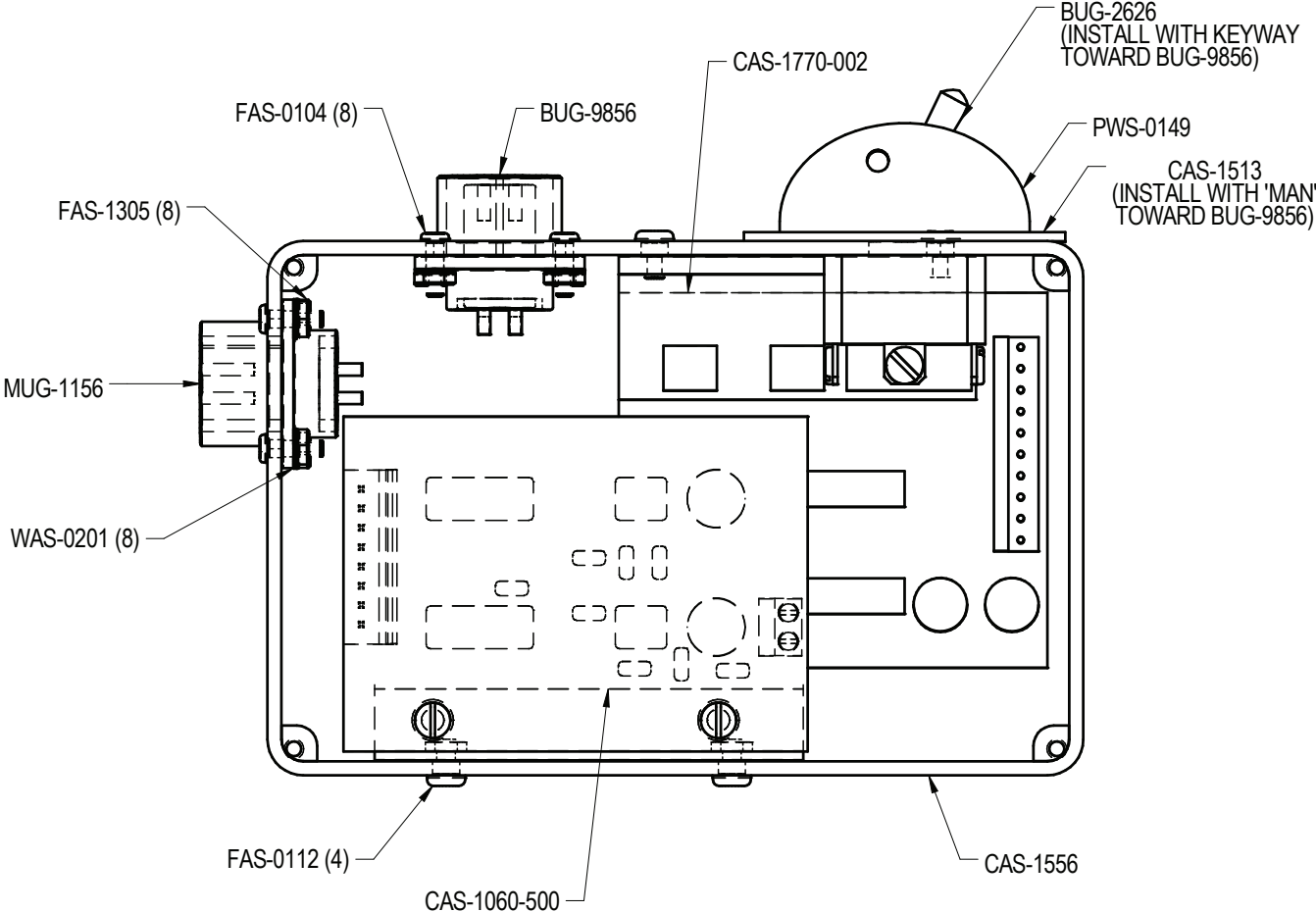


## BUG-5725 CROSS DRIVE ASSEMBLY / EXPLODED VIEW / PARTS LIST

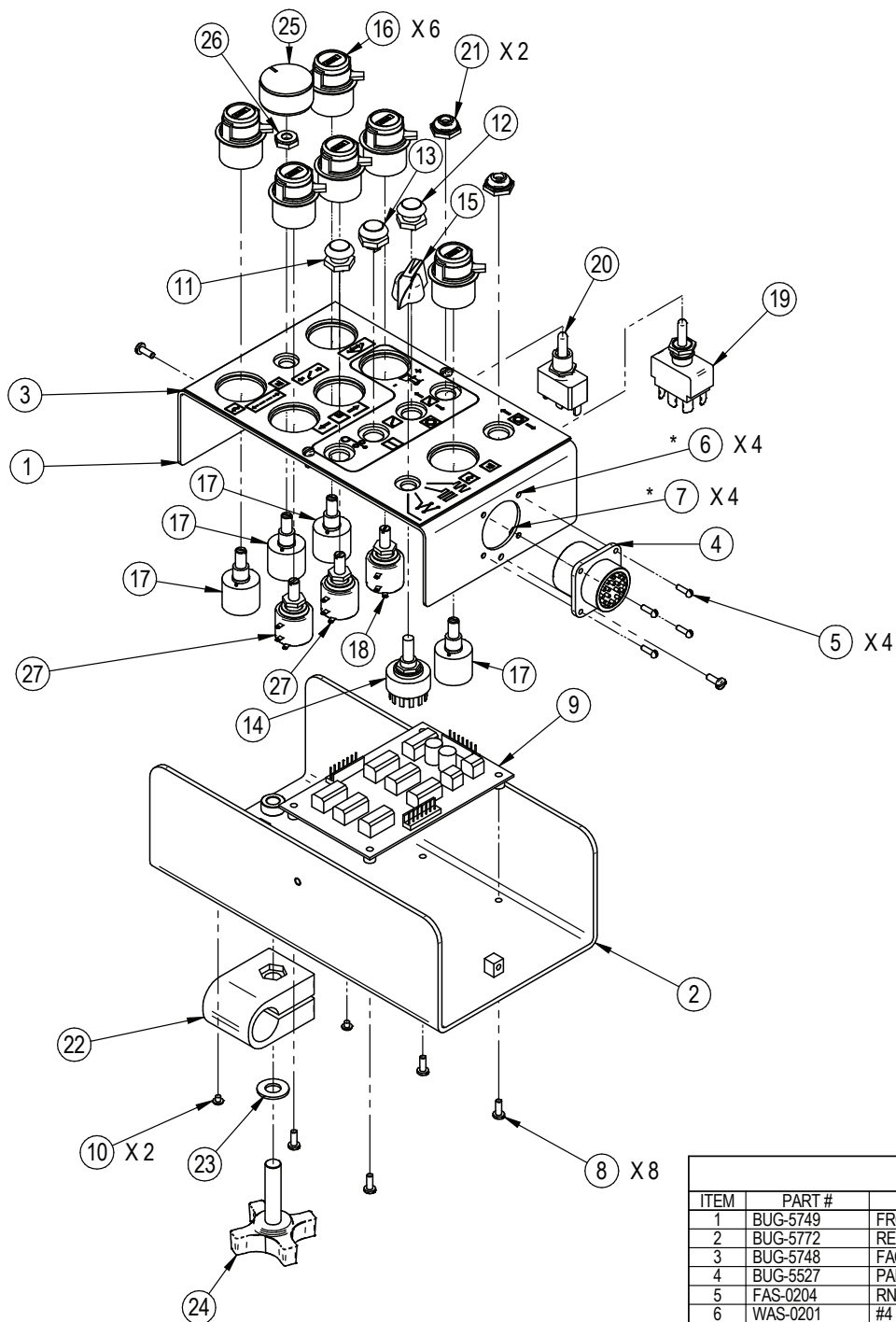
PARTS LIST			
ITEM	PART #	DESCRIPTION	QTY
1	BUG-5590	GEAR MOTOR	1
2	BUG-5591	PINION	1
3	100-0755	MOTOR MOUNT BLOCK ASSEMBLY	1
4	PWS-1045	SHLDR SCR, M6, 8MM SHLDR DIA.	2
5	BUG-5595	POT/GEAR ASSEMBLY	1
6	BUG-5670	ADJ. LEG & WHEEL ASSY.	2
7	BUG-5675	FIXED LEG & WHEEL ASSY.	2
8	BUG-5728-A	MOUNTING PANEL	1
9	WPD-1150	CROSS ARM 15.50"	1
10	WPD-1178	POST W/FASTENERS	1
11	WPD-1164	ARM STOP	1
12	FAS-0539	SOC HD CAP 10-24 X 1"	1
13	MET-1370-SS	M6 HEX NUT	4
14	MET-0944-SS	FLT HD SOC SCR M3 X 12	4
15	N/A	LOCTITE® 222MS™ THREADLOCKER, OR SIMILAR	AS REQ



# CAS-1555 CAS ELECTRONICS BOX / EXPLODED VIEW



# BUG-5755 PENDANT CONTROL / EXPLODED VIEW / PARTS LIST

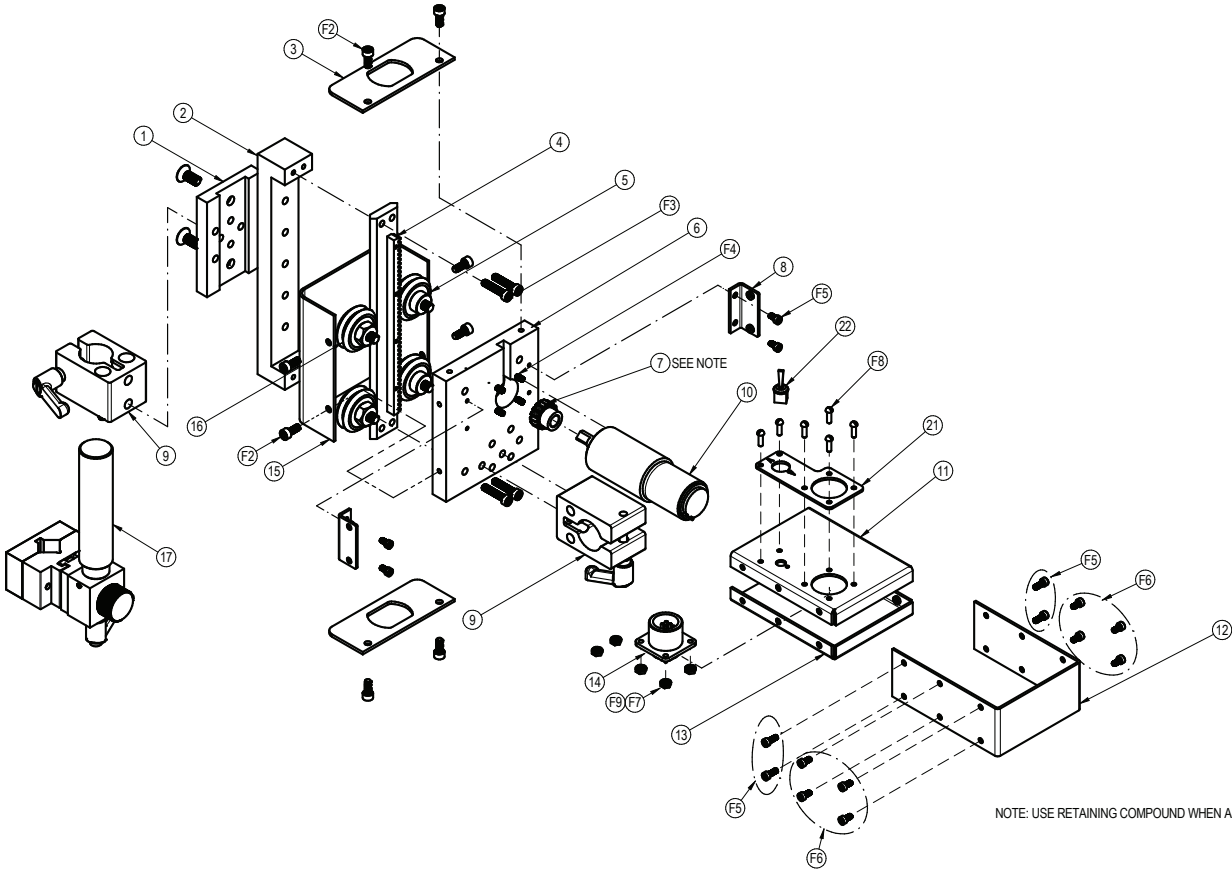


PARTS LIST			
ITEM	PART #	DESCRIPTION	QTY
1	BUG-5749	FRONT PANEL	1
2	BUG-5772	REAR PANEL	1
3	BUG-5748	FACE PLATE	1
4	BUG-5527	PANEL CONNECTOR, 17-T, F	1
5	FAS-0204	RND HD SLT SCR 4-40 X 3/8 ZINC	4
6	WAS-0201	#4 INTERNAL STAR LOCKWASHER	4
7	FAS-1305	HEX NUT 4-40	4
8	FAS-0114	PAN HD SCR 6-32 X 3/8 BLACK	8
9	BUG-5760-UB	CONTROL BOARD, UNIV BUGOMATIC	1
10	MDS-1019	SNAP RIVET, BLACK	2
11	SWT-1111	NOR. OPEN PUSH BUTTON, BLACK	1
12	SWT-1112	N. O. PUSH BUTTON SWITCH RED	1
13	SWT-1113	PUSH BUTTON SWITCH, N.O., GREEN	1
14	BUG-5363	ROTARY SWITCH, 3 POLE, 4 POS.	1
15	BUG-9694	BLACK POINTER KNOB	1
16	BUG-3297	KNOB, DIGITAL DIAL	6
17	BUG-1562	MULTI-TURN POTENTIOMETER	4
18	BUG-1572	POTENTIOMETER	1
19	BUG-2255	TOGGLE SWITCH	1
20	BUG-5761	TOGGLE SWITCH	1
21	BUG-5758	TOGGLE SWITCH SEAL, GRAY	2
22	PAN-1033	ROD CLAMP	1
23	BUG-2034	TEFLON WASHER 3/40DX3/8IDX1/16	1
24	BUG-2436	KNOB SCREW	1
25	BUG-5757	KNOB, BLACK, ALUMINUM	1
26	BUG-5759	POT SHAFT SEAL 1/4" GRAY	1
27	BUG-5768	POT, 10 TURN, 100K	2

\* = NOT SHOWN. INSTALLED INSIDE OF PANEL

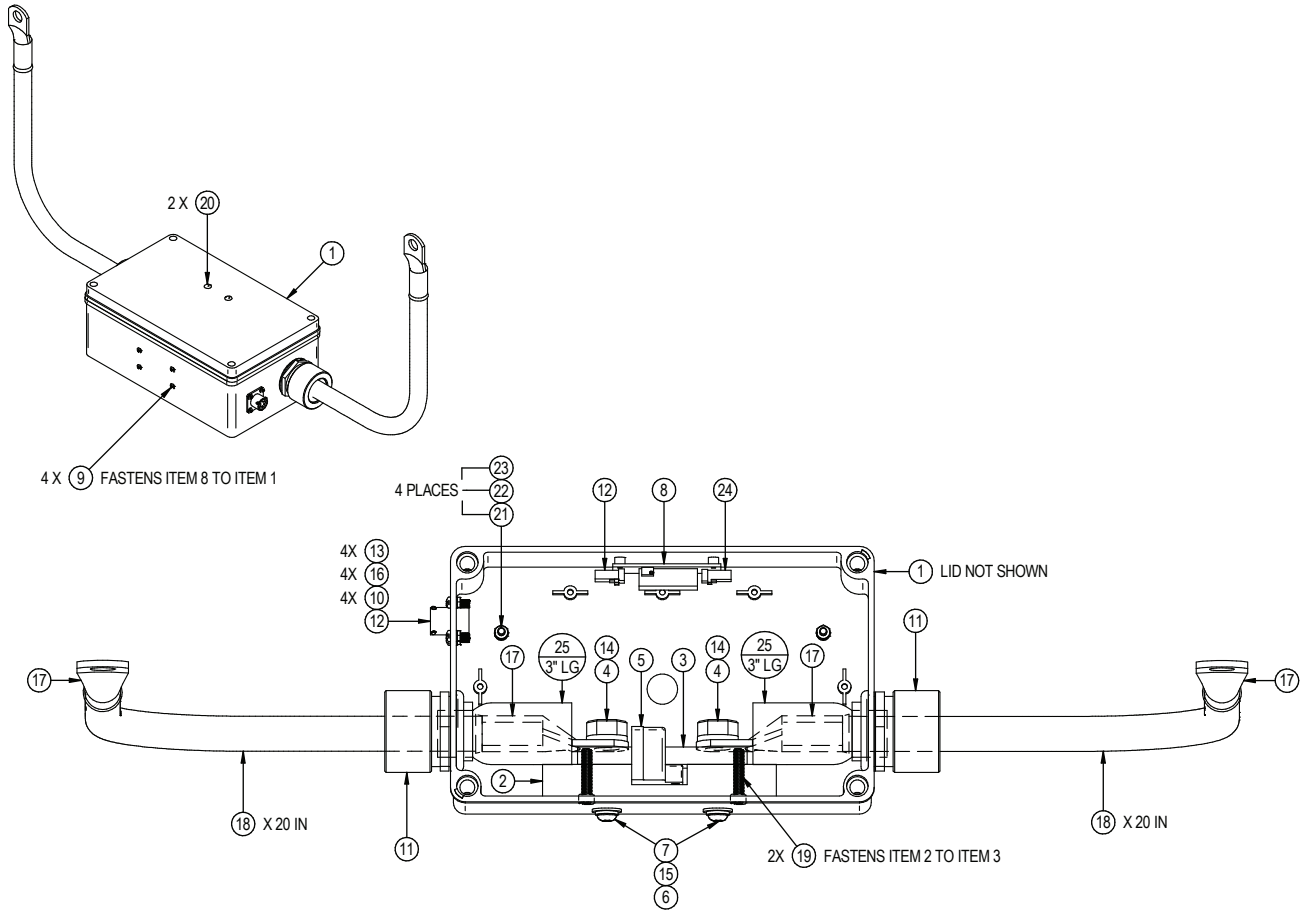


# CAS-1500 HEIGHT SLIDE ASSEMBLY / EXPLODED VIEW / PARTS LIST



BILL OF MATERIALS			
ITEM	PART NUM	DESCRIPTION	QTY
1	CAS-1512	TORCH MOUNT PLATE	1
2	CAS-1509	HEIGHT ARM MOUNTING BAR	1
3	CAS-1523	END CAP	2
4	CAS-1505	HEIGHT ARM ASSEMBLY	1
5	PWS-1028	FIXED WHEEL & LEG ASSY	2
6	CAS-1522	MOUNTING PLATE	1
7	CAS-1511	STEEL PINION	1
8	CAS-1517	CAS DRIVE MOTOR COVER MOUNT ANGLE	2
9	CAS-1510	DUAL POSITION CLAMP BLOCK	2
10	PRS-1035	MOTOR	1
11	CAS-1518	CAS DRV MTR CVR PANEL A	1
12	CAS-1521	CAS DRV MTR OUTER COVER	1
13	CAS-1519	CAS DRV MTR CVR PANEL B	1
14	BUG-1034	PANEL CONNECTOR, 4-T, M	1
15	CAS-1503-P	ARM COVER	1
16	PWS-1029	ADJUSTABLE WHEEL & LEG ASSY	2
17	CAS-1590	QUICK DISCONNECT CLAMP ASSY	1
18	BUG-2708	CLAMP	1
19	GOF-3036	QD FEMALE, FULLY INSULATED	4
20	GOF-3037	TERMINAL, QD, .250" MALE	2
21	AVC-2116	LEGEND PLATE	1
22	SWT-0809	TOGGLE SWITCH	1
F1	MET-0975-SS	FLT HD SOC SCR M6 x 14	2
F2	MET-0553-SS	SOC HD CAP SCR M4 x 10	8
F3	MET-0559-SS	SOC HD CAP SCREW M4 X20	4
F4	MET-0147-SS	PAN HD PHIL SCR M3 x 16	4
F5	MET-0542-SS	SOC HD CAP SCR M3 X 8	8
F6	MET-0541-SS	SOC HD CAP SCR M3 X 6	8
F7	FAS-1305	HEXNUT 4-40	6
F8	FAS-1204	BUT.HD.SK.HD.SCREW 4-40 X 3/8	6
F9	WAS-0201	#4 INTERNAL STAR LOCKWASHER	6

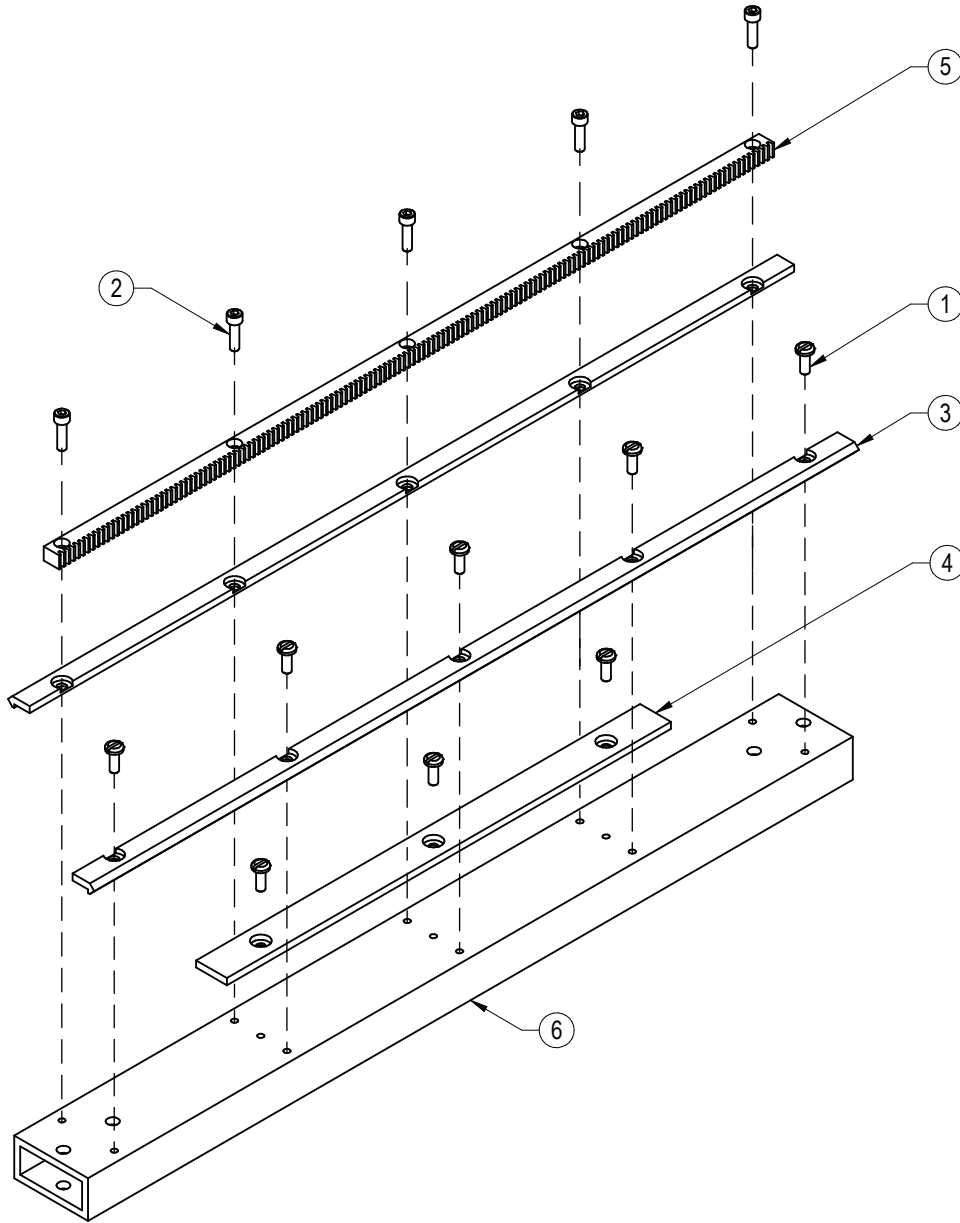
# CAS-1550 HALL EFFECTS CURRENT SENSOR / ASSEMBLED VIEW / PARTS LIST



## PARTS LIST

ITEM	PART #	DESCRIPTION	QTY
1	PWS-0302	9" X 5.5" PLASTIC ENCLOSURE	1
2	100-1266	MICARTA INSULATOR BLOCK	1
3	100-1265	BRASS CURRENT BAR	1
4	FAS-0307	HEX HD CAP SCR 1/2-13 X 3/4	2
5	CAS-1551	500A CURRENT SENSOR	1
6	WAS-0240	1/4 SAE FLAT	2
7	MET-1277	BUTTON HD SOC SCR. M6 X 16	2
8	PCB-1213	HALL EFFECT INTERFACE BOARD	1
9	MET-0141-SS	PAN HD PHIL SCR M3 x 6	4
10	MET-0143-SS	PAN HD PHIL M3 x 10	4
11	PWS-0307	1" CORD GRIP .63" to .75" CABLE	2
12	PWS-0305	MAIN CURRENT SENSE HARNESS	1
13	MET-1340-SS	M3 HEX NUT	4
14	WAS-0281	1/2" SPLIT LOCKWASHER	2
15	WAS-0243	1/4" SPLIT LOCK WASHER	2
16	WAS-5541-SS	M3 INTERNAL STAR LOCK WASHER	4
17	CWO-8062	LUG 3/O-4/O WELD CABLE	4
18	900-0-044	4/O WELDING CABLE, BLACK	40.00 IN
19	MET-2562-SS	SOC HD CAP SCR M5 x 25	2
20	BUG-3331	HOLE PLUG 1/4"	2
21	MET-0577-SS	SOC HD CAP SCR M4 X 16	4
22	WAS-5551-SS	M4 LOCK WASHER STAINLESS STEEL	4
23	MET-1350-SS	M4 HEX NUT ( STAINLESS STEEL)	4
24	PWS-0306	SENSOR HARNESS	1
25	100-1267	FIRESLEEVE, 1.00"ID, 1.160" OD	0.15 M

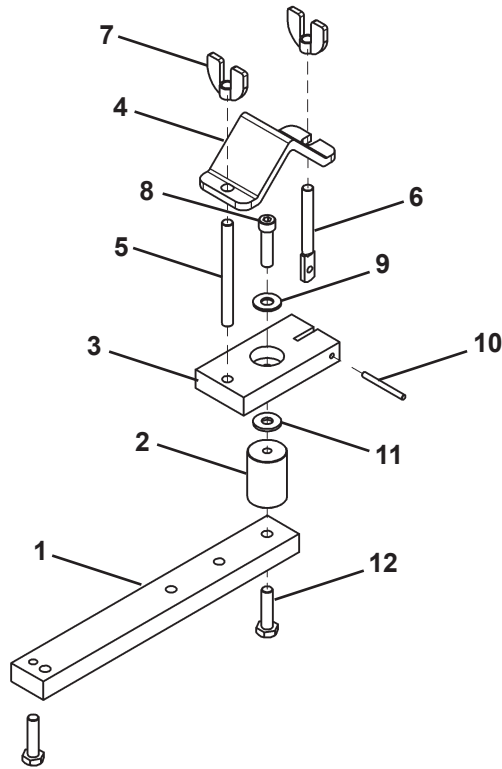
# WPD-1150 CROSS ARM / EXPLODED VIEW / PARTS LIST



## PARTS LIST - WPD-1150

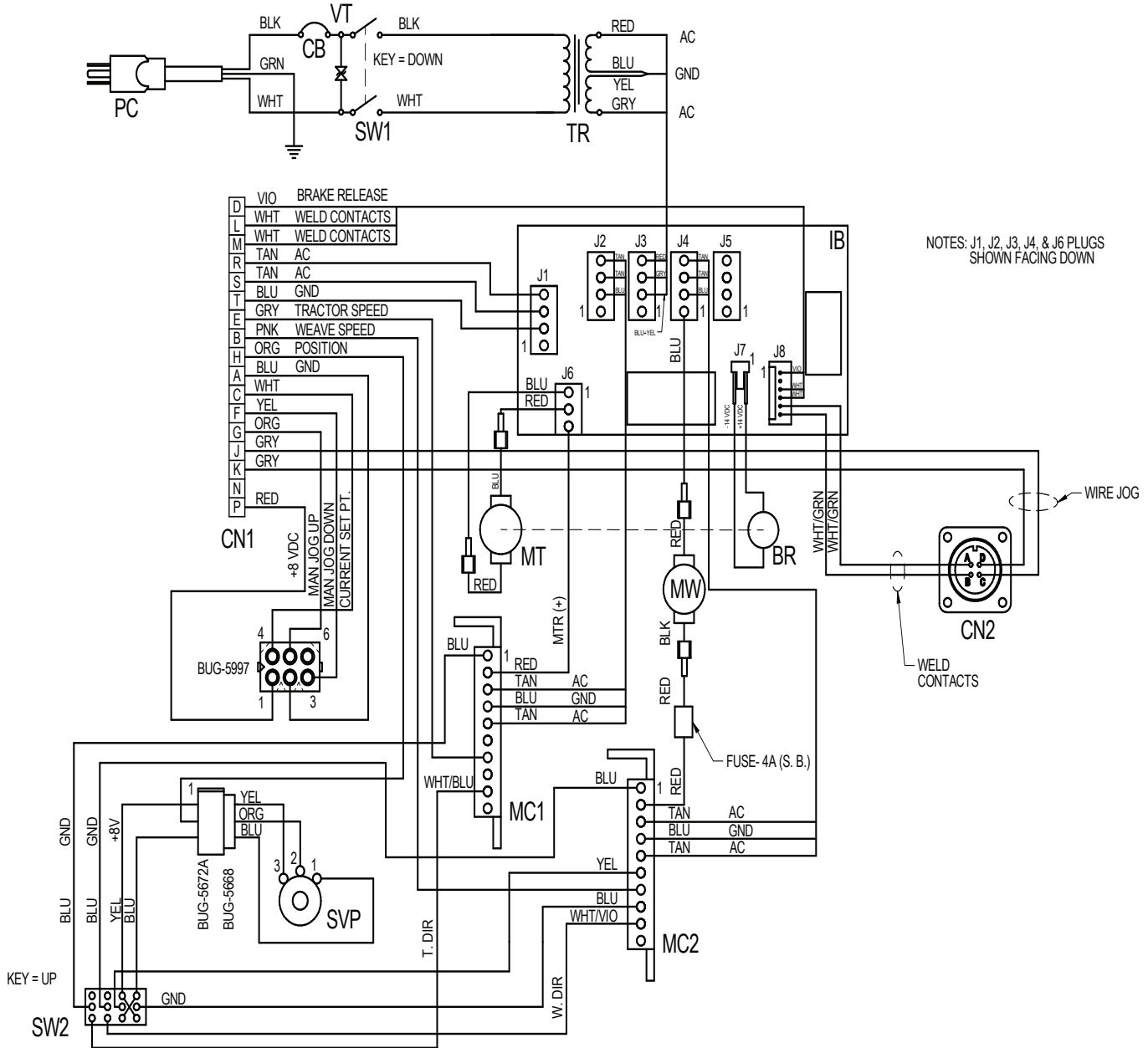
ITEM	PART #	DESCRIPTION	QTY
1	FAS-0114-SS	PAN HD SCR #6-32 X 3/8"	8
2	FAS-0515-SS	SOC HD CAP SCR #6-32 X 1/2"	5
3	WPD-1151	15.500" V-GUIDE	2
4	WPD-1152-3	SPACER PLATE	1
5	WPD-1156	RACK, MACHINED	1
6	WPD-1157	TUBE	1

# BUG-5975 CABLE ANCHOR / EXPLODED VIEW / PARTS LIST



<u>ITEM</u>	<u>QTY</u>	<u>PART NO.</u>	<u>DESCRIPTION</u>
1	1	BUG-5976	Cable Bar
2	1	BUG-9625	Stand-Off
3	1	BUG-2816	Plate
4	1	BUG-2773	Clamp
5	1	BUG-1437	All Thread, 1/4-20 x 2.75"
6	1	BUG-2771	Spade Bolt
7	2	BUG-2085	Wingnut, 1/4-20
8	1	FAS-0559	Screw, Soc Hd Cap 1/4-20 x 1"
9	1	WAS-0240	Washer, SAE Flat 1/4"
10	1	RPS-2121	Roll Pin, 1/8 x 1.25"
11	1	BUG-2063	Delrin Washer
12	2	FAS-0359	Screw, Hex Hd Cap 1/4-20 x 1"

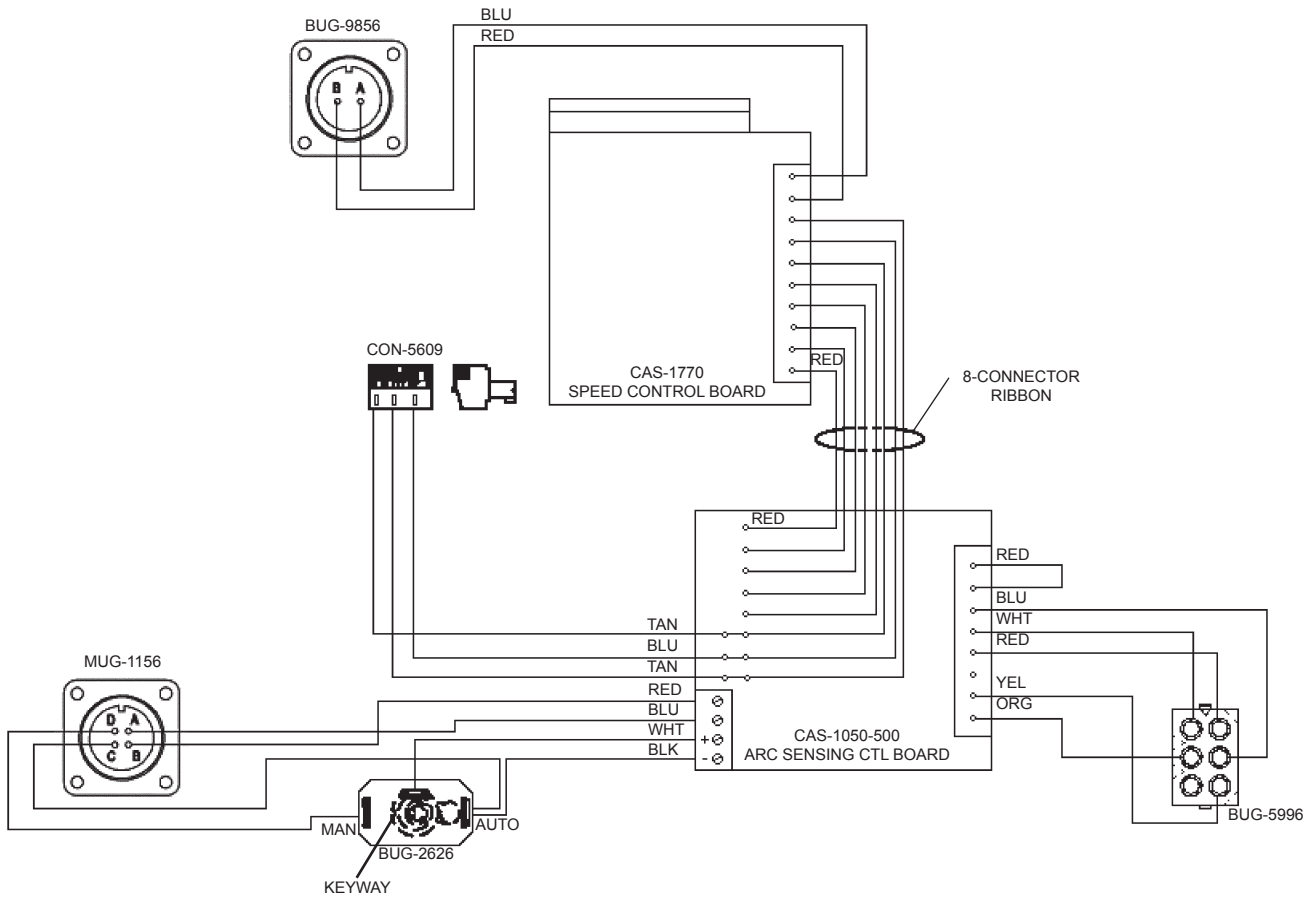
# BUG-598X DRIVE UNIT / WIRING DIAGRAM



## BUG-598X DRIVE UNIT / ELECTRICAL COMPONENT CHART

ITEM	DESCRIPTION	BUG-5990 120 VAC	BUG-5992 240 VAC	BUG-5994 42 VAC
PC	Power Cord	BUG-9445	GOF-3115	BUG-9442
VT	Volt Trap	BUG-1393	BUG-1563	BUG-1393
CB	Circuit Breaker	BUG-2923	BUG-2952	BUG-2933
TR	Transformer	BUG-5218	BUG-5231	BUG-5232
SW1	Toggle Switch	ARM-2279		
IB	Interconnect Board	PCB-5700		
CN1	Connector, to Pendant	BUG-5527		
CN2	Connector, to Weld Contact	BUG-1034		
MT	Tractor Motor	MPD-1015		
BR	Brake	WPD-1045		
MW	Weave Motor	BUG-5590		
MC1	Motor Control, Tractor	BUG-1770-UB		
MC2	Motor Control, Weave	CAS-1770-001		
SVP	Servo-Pot	BUG-5240		
SW2	Toggle Switch	SWT-0503		

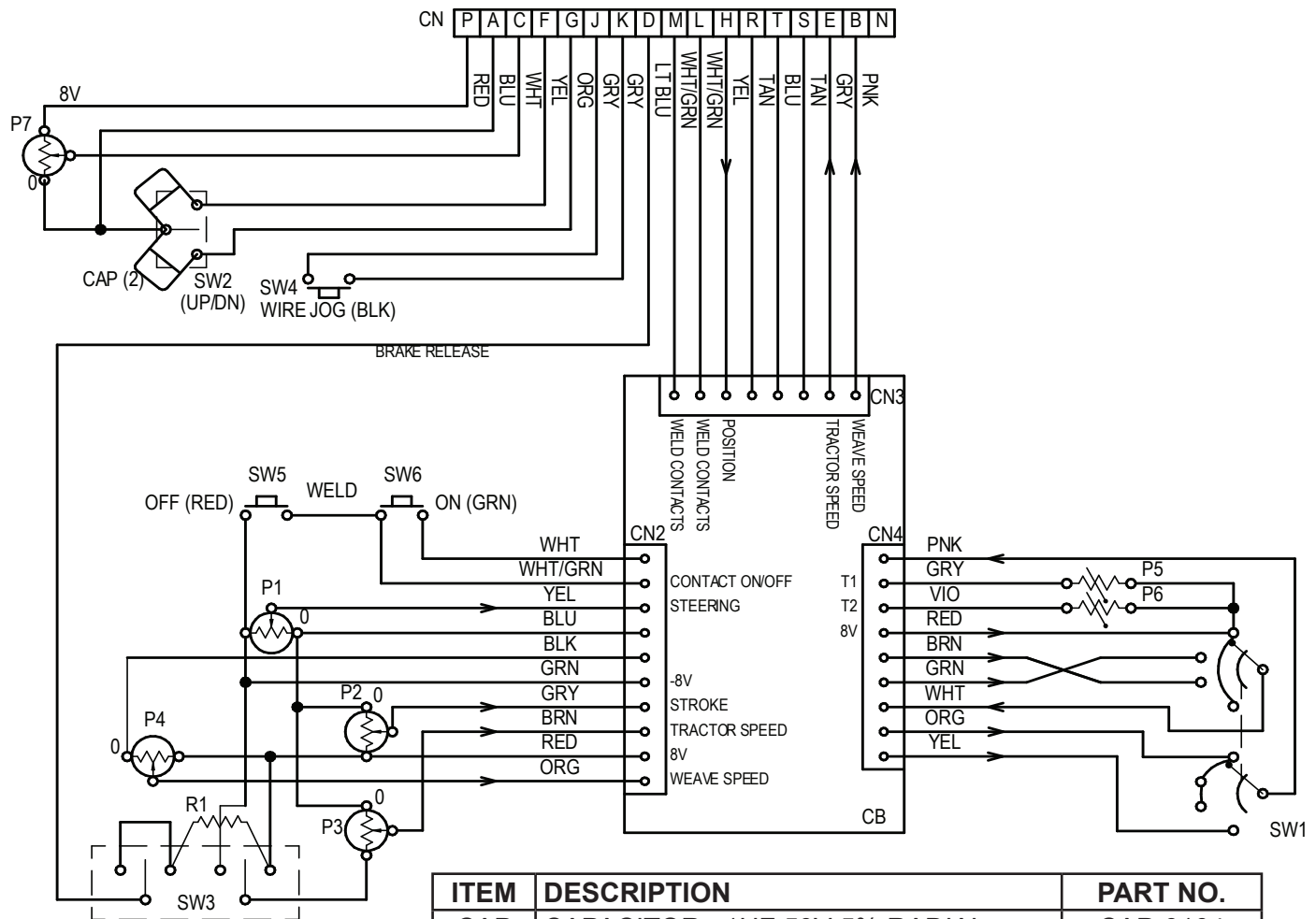
# CAS-1555 CAS ELECTRONICS / WIRING DIAGRAM / ELECTRICAL COMPONENT CHART



PART NO.	DESCRIPTION
BUG-2626	Switch
BUG-5996	Plug, 6-Pos, F
BUG-9856	Panel Connector, 2T, F
CAS-1050-500	Arc Sensing Control Board
CAS-1770-002	Speed Control Board
CON-5609	Plug, 4-Pos
MUG-1156	Panel Connector, 4T, F



# BUG-5755 CONTROL PENDANT / WIRING DIAGRAM / ELECTRICAL COMPONENT CHART



ITEM	DESCRIPTION	PART NO.
CAP	CAPACITOR, .1UF 50V 5% RADIAL	CAP-0104
CB	CONTROL BOARD	BUG-5760-UB
CN	CONNECTOR	BUG-5527
CN2	HOUSING 10 PIN	CNN--012A
CN3	HOUSING 8 PIN	CNN-0128
CN4	HOUSING 9 PIN	CNN-0129
P1	STEERING POT	BUG-1562
P2	AMPLITUDE POT	BUG-1562
P3	TRACTOR SPEED POT	BUG-1562
P4	WEAVE SPEED POT	BUG-1562
P5	DWELL POT	BUG-5768
P6	DWELL POT	BUG-5768
P7	CURRENT SET POT	BUG-1572
R1	RESISTOR, 1K 1/4W 5% CARBON FILM	RES-0102
SW1	WEAVE PATTERN SWITCH	BUG-5363
SW2	MANUAL JOG SWITCH	BUG-5761
SW3	TRACTOR SPEED SWITCH	BUG-2255
SW4	WIRE JOG SWITCH	SWT-1111
SW5	WELD OFF SWITCH	SWT-1112
SW6	WELD ON SWITCH	SWT-1113

## RAIL OPTIONS

With a simple carriage change, the Universal Bug-O-Matic with AHC can be made compatible with any BUG-O rail. A brief description of each BUG-O rail type is provided below. Contact your BUG-O representative for more information about these rails and the mounting options available.

### ARR-1080 ALUMINUM RIGID RAIL / CROSS SECTION / EXPLODED VIEW / PARTS LIST

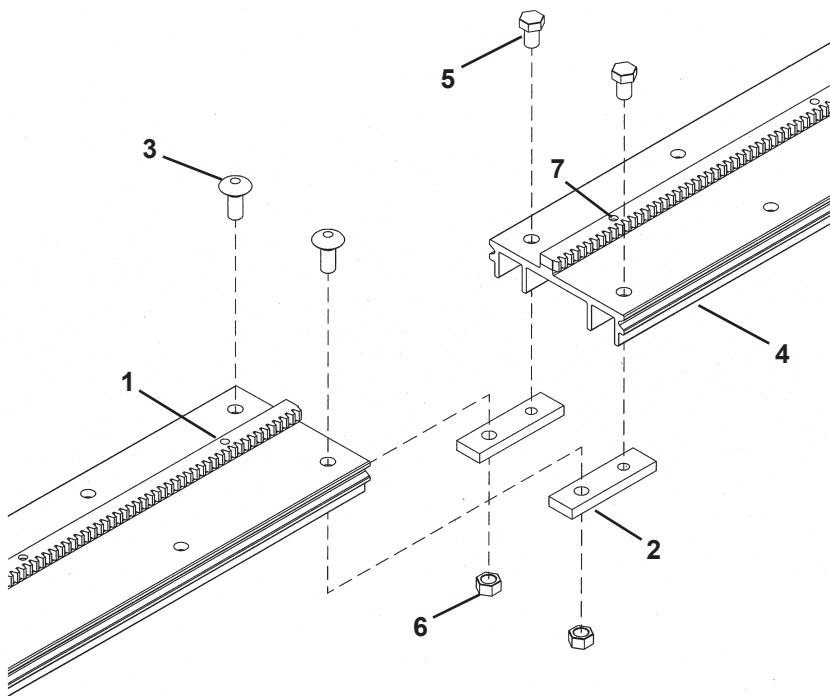
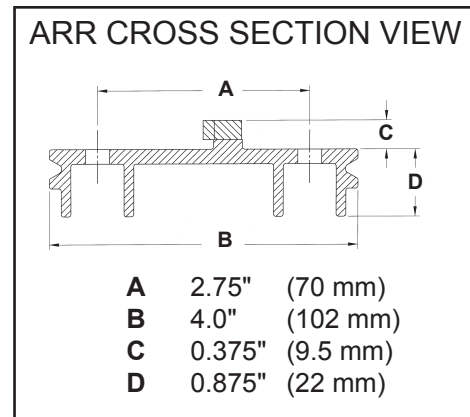
ALUMINUM RIGID RAIL is a rigid channel section made of high quality alloy to machine tool tolerance as in the section view below. A machined gear rack is mounted on the rail, with which the drive pinion of the carriage meshes. The wheels of the carriage travel in opposed grooves at either side of the rail, locking the carriage to the rail.

Heavy duty [H.D] aluminum four-legged rigid rail is supplied in two lengths:

- ARR-1080 [93-1/2" (2.37 m)] called 8' (2.37 m) rail
- ARR-1085 [46-1/2" (1.18 m)] called 4' (1.18 m) rail.

Extra Heavy Duty aluminum four-legged rigid rail is also available:

- ARR-1250 [93-1/2" (1.18 m)] called 8' (2.37 m) rail
- ARR-1200 [46-1/2" (1.18 m)] called 4" (1.18 m) rail.



#### PARTS LIST

<u>ITEM</u>	<u>PART NO.</u>	<u>DESCRIPTION</u>	<u>QTY</u>
1	ARR-1006	Rack	1
2	ARR-1027	Splicer Bar	2
3	ARR-1028	Carriage Bolt	2
4	ARR-1081	Rail Extrusion	1
5	FAS-0375	Screw, Hex Hd Cap 5/16-18	2
6	FAS-1370	Hex Nut 5/16-18	2
7	FAS-1445	Phil Pan Hd Scr 10-32 x01/2 Zinc	16

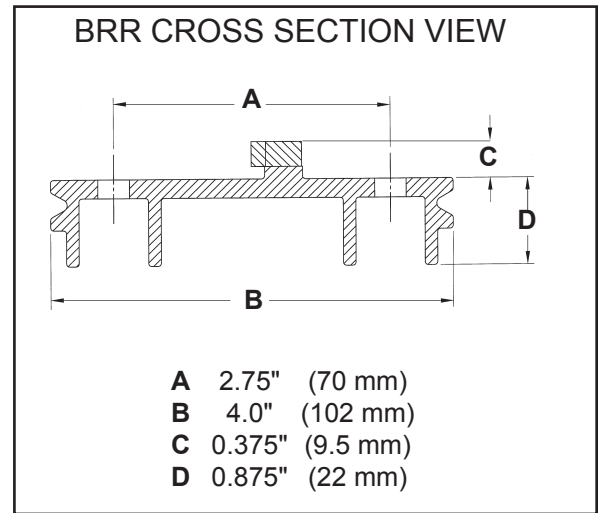
#### RAIL FOR LONGER SPANS:

When unsupported rail paths longer than nominal 8' (2.37 m) rail are required, multiple sections of standard rail are mounted on plate, I beam, channel or box sections.

# BRR-1180 BENT RIGID RAIL / CROSS SECTION / APPLICATION VIEW / PARTS LIST

BENT RIGID RAIL (BRR) is a rigid section of high quality alloy bent for circumferential applications. A machined gear rack is mounted on the rail, with which the pinion of the drive unit meshes, providing positive drive in all directions. The wheels of the carriage travel in opposed grooves at either side of the rail, securing the carriage to the rail.

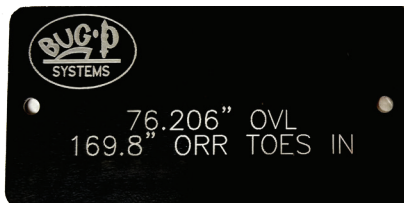
The rail is ordered as a complete ring (BRR-1210-\_\_\_). When ordering, specify the work diameter (inside or outside), method of mounting and if a complete ring is required. On larger diameters, rail can be "leapfrogged" around the vessel to reduce the quantity needed. Maximum section length is 80" (2 m).



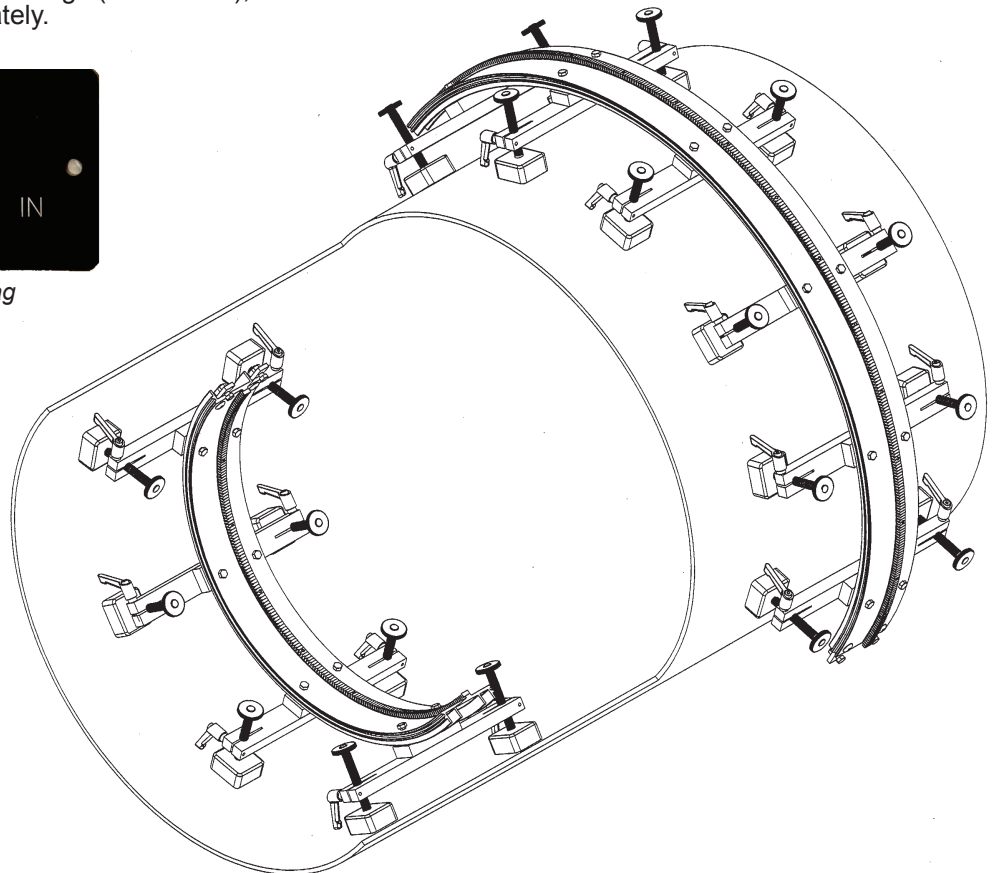
## SPARE PARTS LIST

<u>PART NO.</u>	<u>QTY</u>	<u>DESCRIPTION</u>
ARR-1027	2	Splicer Bar
ARR-1028	2	Carriage Bolt
FAS-0375	2	Screw, Hex Hd Cap 5/16-18
FAS-1370	2	Hex Nut 5/16-18
FAS-1445	16	Phil Pan Hd Scr 10-32 x 1/2 Zinc

Note: Adjustable magnet support legs (ARM-2480), shown above, are sold separately.

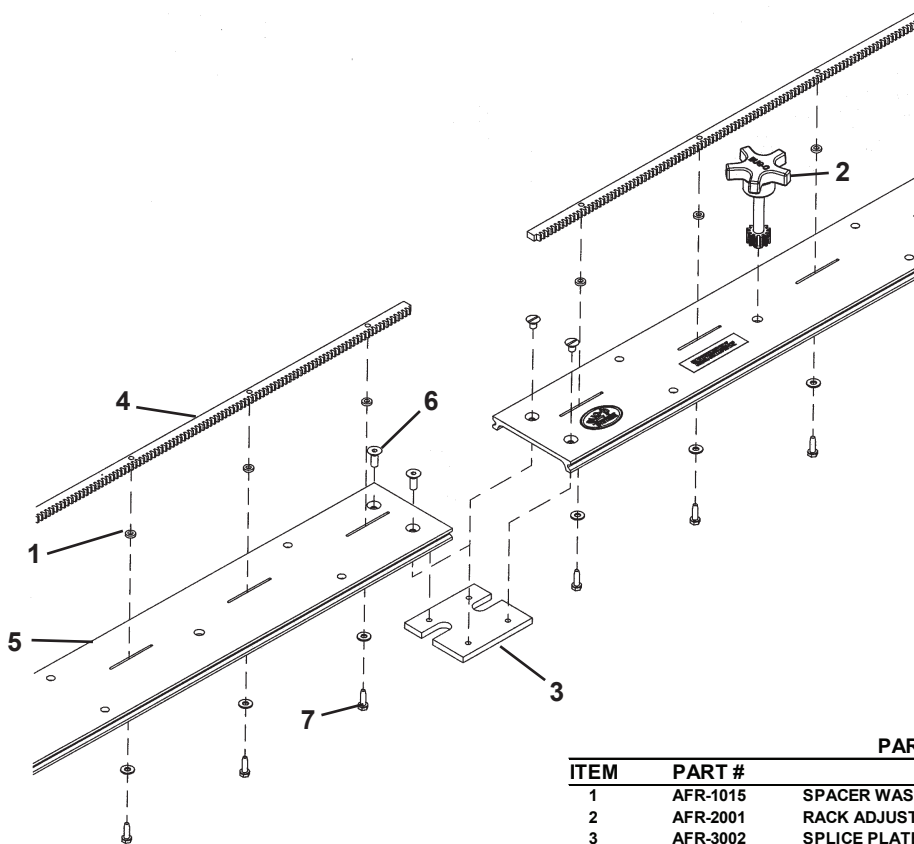
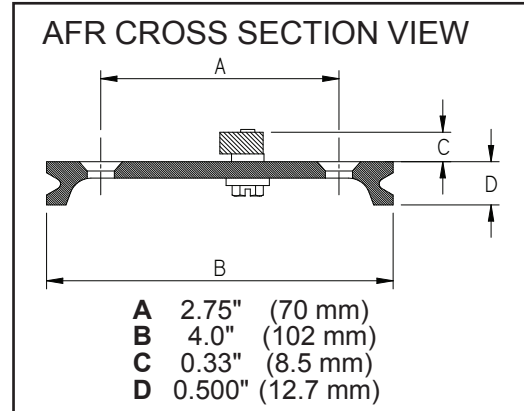
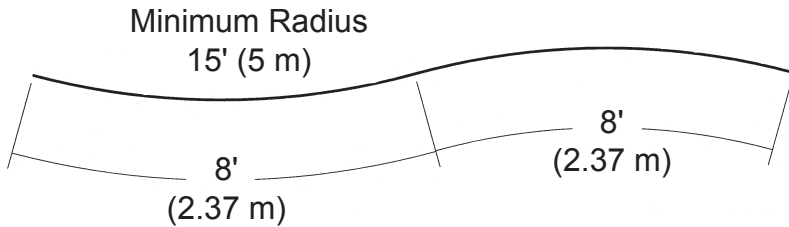


*BRR Identification Tag*



# AFR-3000 SEMI-FLEX RAIL / CROSS SECTION / EXPLODED VIEW / PARTS LIST

SEMI-FLEX RAIL (AFR) can be bent inside or outside to a minimum radius of 15' (5 m) without permanent deformation. A splice plate is mounted at one end of each flex-rail section for connecting multiple sections of rail. A rack adjusting tool is supplied with every two (2) rails, for moving the rack on the rail. Available in 8' ( 2.37 m) lengths. Use at least four (4) attachments - vacuum cups or magnets - on each section of Semi-Flex Rail.

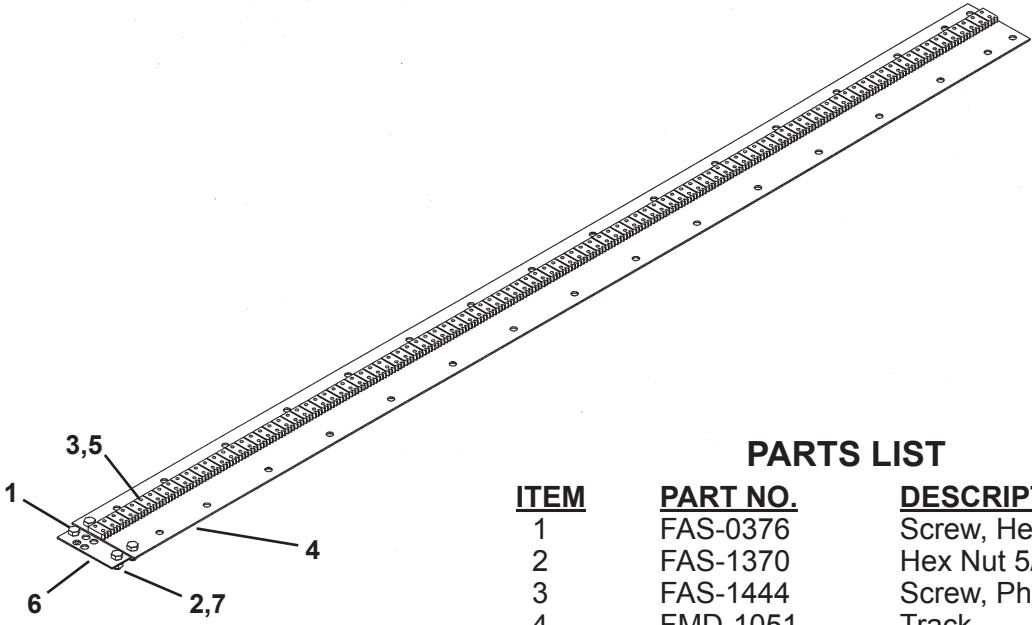
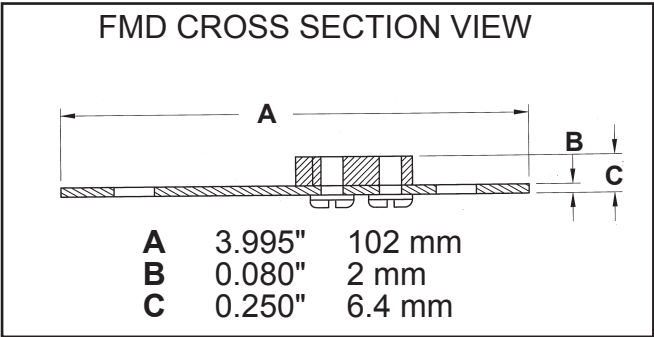
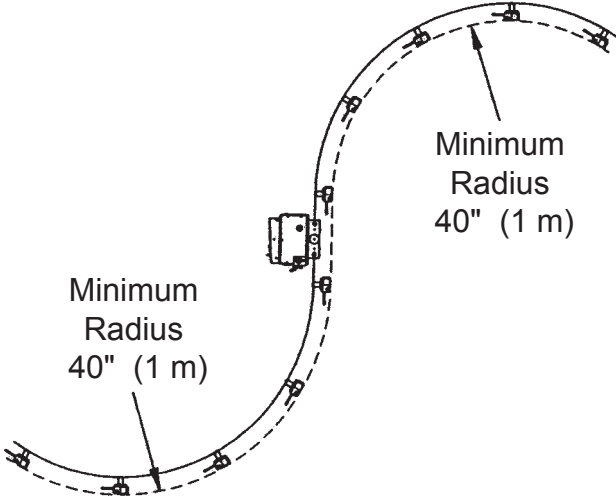


## PARTS LIST

ITEM	PART #	DESCRIPTION	QTY
1	AFR-1015	SPACER WASHER	16
2	AFR-2001	RACK ADJUSTER TOOL	1
3	AFR-3002	SPLICE PLATE	1
4	AFR-3006	RACK	1
5	AFR-3009	EXTRUSION, PUNCHED	1
6	FAS-0955	FLT HD SOC SCR 1/4-20 X 1/2"	4
7	FAS-1446-HD-0.50D	S.T.SLT.HX.10-32 X 9/16 W/WSH,TYPE F, .500 WSH OD	16

# FMD-1050 HI-FLEX RAIL / CROSS SECTION / ASSEMBLED VIEW / PARTS LIST

HI-FLEX RAIL is made from heavy duty, wear resistant stainless steel with steel rack. The rail comes in 57.7" (1.47 m) lengths and can be held in place with vacuum cups or magnets. This rail can be used in straight applications or for bends down to 40" (1 m) radius, in or out. Hi-Flex rail can be used on compound curvatures and can be twisted 10° per 24" (600 mm) of length.



## PARTS LIST

<u>ITEM</u>	<u>PART NO.</u>	<u>DESCRIPTION</u>
1	FAS-0376	Screw, Hex Hd Cap 5/16-18
2	FAS-1370	Hex Nut 5/16-18
3	FAS-1444	Screw, Phil Pan Hd 10-32
4	FMD-1051	Track
5	FMD-1052	Rack Section, 3 Teeth
6	FMD-1053	Flex-Rail Splice Plate
7	WAS-0250	Washer, SAE 5/16

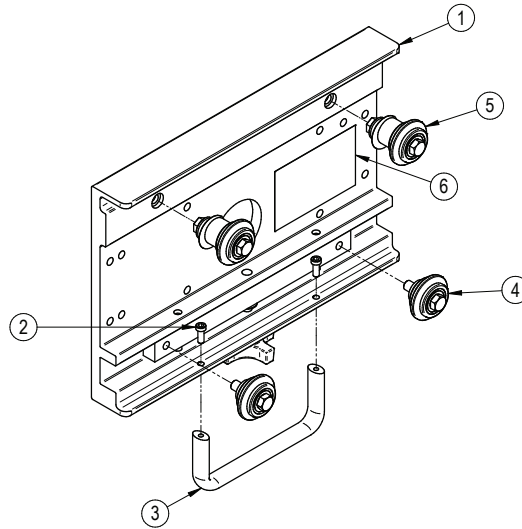
## CARRIAGE OPTIONS

The Universal Bug-O-Matic with AHC can be used with many BUG-O carriages, allowing it to be used on any BUG-O rail. Each carriage is made of high-strength, lightweight aluminum alloy, with wheels that ride in or along the rail to provide smooth, accurate travel. On each carriage, one set of wheels is adjustable. All wheels contain permanently lubricated, sealed bearings and their steel components are plated to resist corrosion.

### MPD-1065 RELEASABLE CARRIAGE / EXPLODED VIEW / PART LIST

The MPD-1065 Releasable 12" Carriage has a carrying capacity of 100 lb (45 kg) and can be placed anywhere on the rail by using the knob located on the side of the carriage, which engages or disengages the wheels from the rail. Use with BUG-O Aluminum Rigid or Semi-Flex Rails.

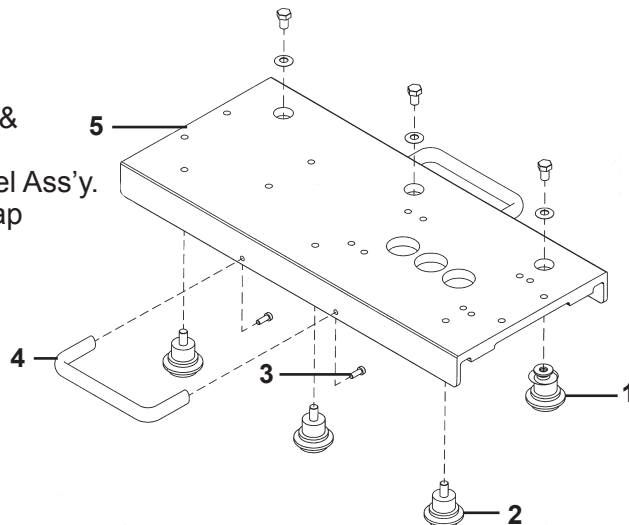
<u>ITEM</u>	<u>QTY</u>	<u>PART NO.</u>	<u>DESCRIPTION</u>
1	2	BUG-1984	External Adj. Leg & Wheel Assembly
2	2	FAS-0545	Screw, Soc Hd Cap 10-32 x 1/2
3	2	MPD-1045	Fixed Leg & Wheel Assembly
4	1	MPD-1049	Handle, Black
5	1	MPD-1059	Knob Screw (Included w/carriage)
6	1	MPD-1066	Carriage



### MPD-1055 CARRIAGE 18" / EXPLODED VIEW / PART LIST

The 18" Carriage provides an extended deck for mounting accessories, wire feeder, etc. and has a carrying capacity of 150 lb. (67.5 kg). Use with BUG-O Aluminum Rigid Rail.

<u>ITEM</u>	<u>QTY</u>	<u>PART NO.</u>	<u>DESCRIPTION</u>
1	3	BUG-1984	External Adj. Leg & Wheel Assembly
2	3	BUG-2956	Fixed Leg & Wheel Ass'y.
3	4	FAS-0545	Screw, Soc Hd Cap 10-32 x 1/2
4	2	MPD-1049	Handle, Black
5	1	MPD-1055-18	Carriage 18"

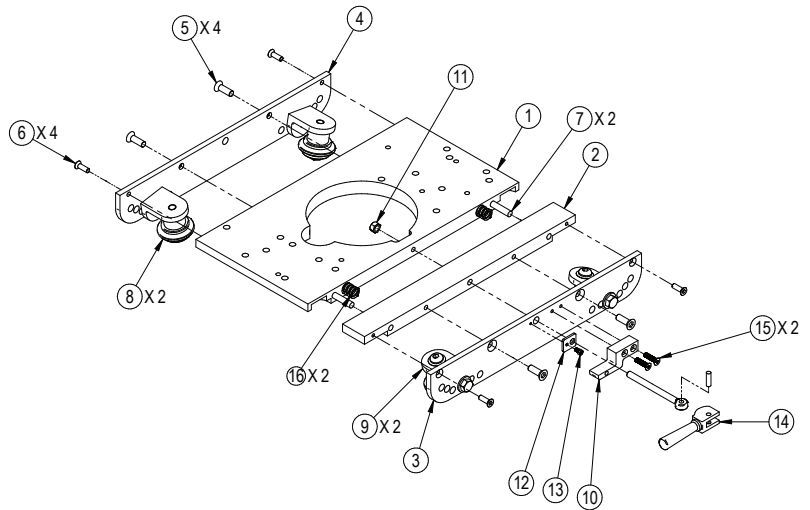


# BUG-5960 TUBE CARRIAGE / EXPLODED VIEW / PARTS LIST

The Tube Carriage features a split carriage body for quick and easy placement on the rail. It has a carrying capacity of 100 lb (45 kg). The carriage also offers six (6) wheel positions for circumferential applications over a wide range of diameters. Use with BUG-O Aluminum Rigid, Semi-Flex or Bent Rigid Rails.

PARTS LIST			
ITEM	PART #	DESCRIPTION	QTY
1	BUG-5908	LEFT PLATE	1
2	BUG-5906	RIGHT PLATE	1
3	BUG-5964	CARRIAGE SIDE PLATE	1
4	BUG-5907	SKIRT, RIGHT	1
5	FAS-0957	1/4-20 X 3/4 FLAT HD SOCKET	4
6	FAS-0935	FLT HD SOC SCR 10-24 X 1/2	4
7	BUG-5912	DOWEL PIN 18/8 STAINLESS	2
8	BUG-5918	FIXED ANGLE LEG & WHEEL ASSY.	2
9	BUG-5920	ADJ ANGLE LEG & WHEEL ASSY.	2
10	PWS-5965	CAM STOP BLOCK	1
11	FAS-1351	HEX NUT 1/4-20	1
12	PWS-5966	CAM HANDLE WASHER	1
13	MET-0541-SS	SOC HD CAP SCR M3 X 6	1
14	PWS-5967	CAM HANDLE ASSEMBLY	1
15	MET-0958-SS	FLT HD SOC SCR M4 X 18	2
16	BUG-5911	SPRING	2
17	BUG-1979	LABEL	1

\* = NOT SHOWN

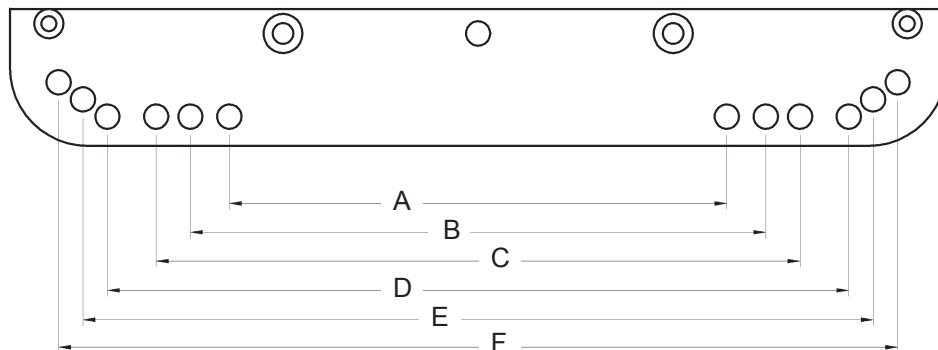


## INSTALLING THE BUG-5960 DRIVE CARRIAGE

- Select the correct pair of holes on each side of the carriage for the rail diameter being used (see chart). If the wheels are not attached to the correct set of holes, remove them and bolt the wheel brackets in selected holes. Tighten the bolts until the brackets are snug, but still free to rotate.
- Open the cam handle to separate the carriage. On the drive unit, loosen and turn the clutch knob counterclockwise to declutch the drive pinion.
- Place the carriage on the rail with the wheels in the rail grooves. Close the cam handle and move the carriage back and forth a few inches. The wheels on their mounting brackets will align themselves correctly in the rail grooves.
- Verify that wheels are properly aligned, then tighten the wheel mounting bolts to lock them in position. Rotate the clutch knob clockwise to engage the drive pinion with the rack.
- Verify that pinion is properly engaged in the rack. The correct wheel position will provide a minimum of 1/8" engagement (approx. 3 mm) between the drive pinion and the gear rack. **Note:** For some rail or pipe sizes, the pinion height may need to be adjusted.

Carriage Wheel Hole Set	BRR-1210 Rail ID		Pipe OD	
	in	mm	in	mm
A	20 - 25	500 - 635	9 - 21	230 - 530
B	23 - 35	585 - 890	12 - 31	300 - 790
C	30 - 44	760 - 1120	18 - 40	455 - 1015
D	41 - 60	1040 - 1525	29 - 54	735 - 1375
E	75 - 174	1905 - 4420	64 - 170	1625 - 4320
F	flat rail		flat rail	

**Note:** Chart values are for reference only

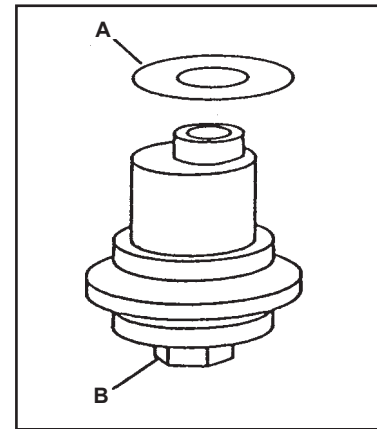




## CARRIAGE WHEEL ADJUSTMENT

The MDS-1055, MDS-1065 and BUG-5960 carriages feature wheels that ride in grooves along the side of the rail. For each of these carriages, the adjustable wheels have stainless steel shim washers (A) underneath. Readjust these wheels (if necessary) by rotating the hex bolt (B) with a 1/2" wrench.

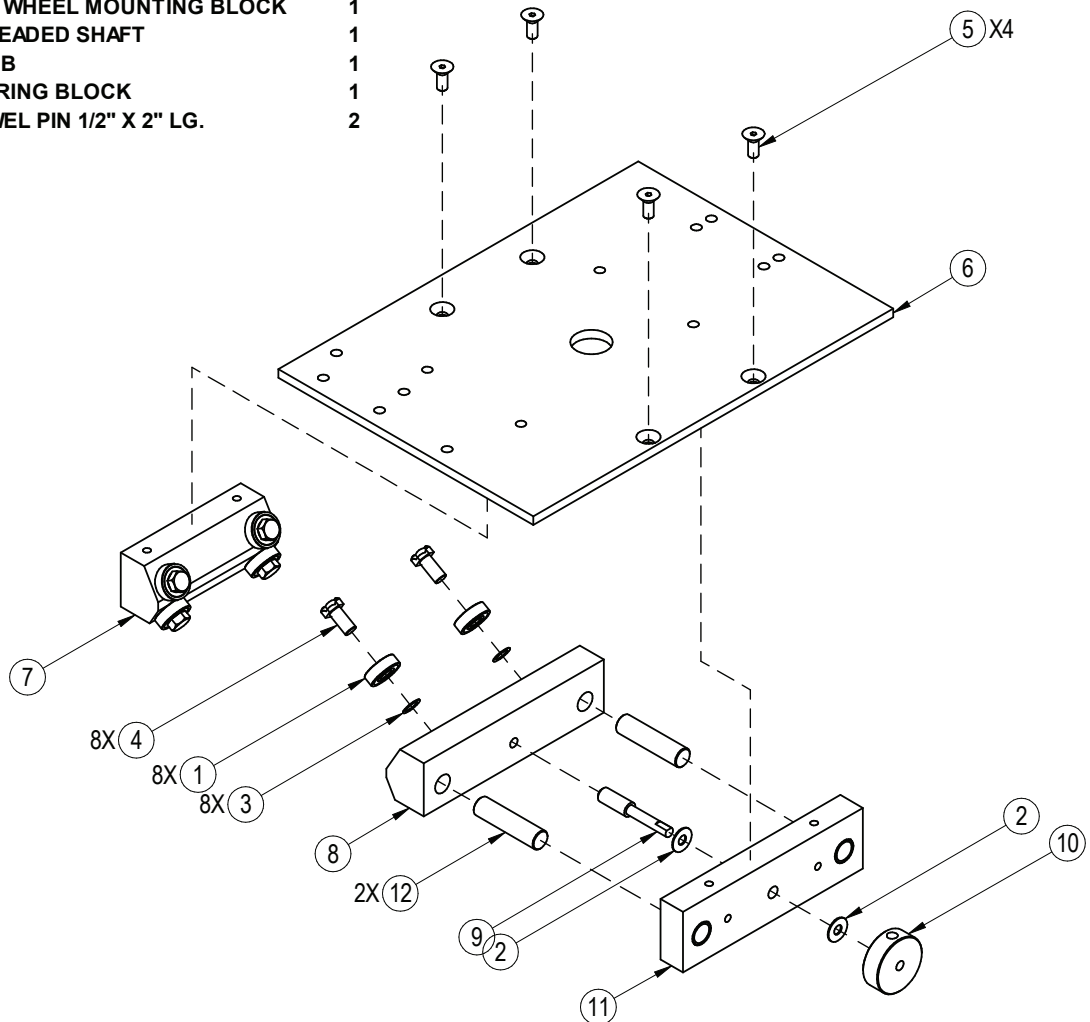
Grasp the sides of the carriage. The wheels are too loose if it is possible to move the carriage from side to side or up and down. Use a finger to keep one of the adjustable wheels from rotating as the carriage is manually pushed along the track. The wheels are adjusted too tight if firm finger pressure is not enough to prevent wheel rotation. Repeat the process for the other adjustable wheel.



## FMD-1022 FLEX RAIL CARRIAGE / EXPLODED VIEW / PARTS LIST

### PARTS LIST

ITEM	PART #	DESCRIPTION	QTY
1	BUG-2012	BEARING	8
2	BUG-2848	CAM BEARING	2
3	CON-1029	WASHER 5/16 X .015	8
4	FAS-0386	HEX HD CAP SCR 5/16-24 X 5/8"	8
5	FAS-0956	FLT HD SOC SCR 1/4-20 X 5/8"	4
6	FMD-1026	CARRIAGE COVER	1
7	FMD-1068	FIXED WHEEL MOUNTING BLOCK	1
8	FMD-1069	ADJ. WHEEL MOUNTING BLOCK	1
9	FMD-1071	THREADED SHAFT	1
10	FMD-1072	KNOB	1
11	FMD-1081	BEARING BLOCK	1
12	FMD-1083	DOWEL PIN 1/2" X 2" LG.	2



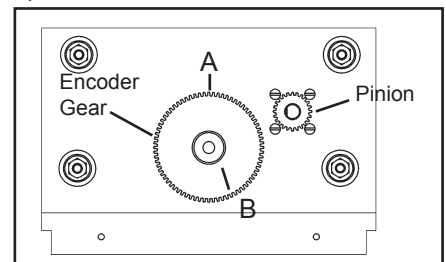
# SERVICE PROCEDURE: INSTALLING THE CROSS ARM (WPD-1150)

## OPTION 1 - In the Field

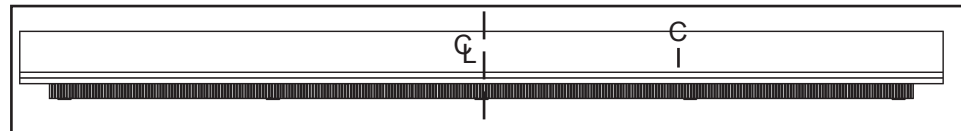
**NOTE:** Read and understand whole procedure before attempting.

Tools required - flash light or well lighted area, marking pen, tape measure or other measuring device.

1. Place machine on blocks to protect the drive pinion (underneath).
2. Turn machine OFF and disconnect from power supply.
3. Remove the Arm Stop (WPD-1164) and the Height Slide Assembly (CAS-1500).
4. Remove the existing Cross Arm (WPD-1150). Manually push/pull the Cross Arm from the machine
5. Looking from the clutch side of the drive unit, locate the reference mark on the mounting plate ("A" in Figure 1) and the reference mark on the face of the brass encoder gear ("B" in Figure 1).
6. As shown in Figure 1, position reference "B" at approximately the 5 o'clock position.
7. Make a mark on the cross arm 3 5/8" right of center ("C" in Figure 2). This will serve as a reference line for centering the cross arm.

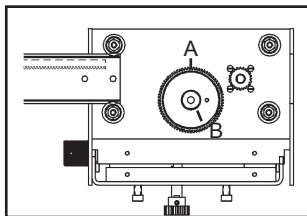


**Figure 1:** Proper positioning of reference marks A and B before the V-guide is inserted.

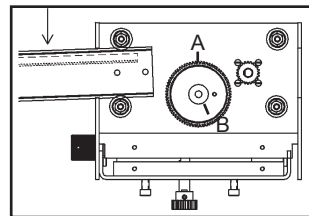


**Figure 2:** Placement of reference mark C on the V-guide.

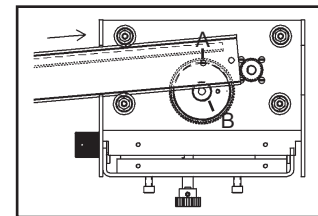
8. Inserting from the brass gear side, install the Cross Arm, as shown in figures 3-7.



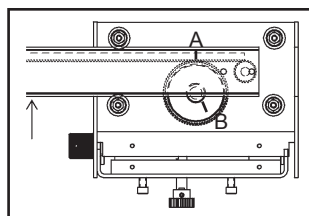
**Figure 3:** Insert Cross Arm into guide wheels.



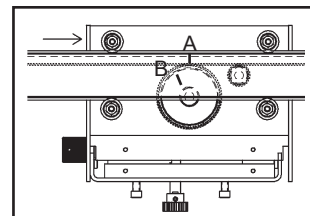
**Figure 4:** Push down on arm to tilt V-guide up.



**Figure 5:** Push cross arm into machine. Avoid brass gear



**Figure 6:** When arm is ready to mesh with pinion, push up on arm.



**Figure 7:** Push cross arm in until it is centered.

Be careful not to bump or mesh brass gear and V-guide rack until V-guide is ready to engage pinion also. Run the Cross Arm until it is centered (align reference mark "C" with face of side plate). Make sure the brass gear teeth and the V-guide teeth do not skip.

9. If necessary, connect the Pendant Control (BUG-5755) to the Drive Unit (BUG-5980) using the Pendant Control Cable (BUG-5551-10).
10. On the control pendant, center steering control (1 1/2 turns from either extreme).
11. Connect the machine to a power supply of the proper voltage and turn machine ON to verify that Cross Arm is centered. The centered V-Guide should stick out of the machine by about 4.25 in (110 mm) on each side.
12. If satisfied with position of Cross Arm, install Arm Stop and Height Slide Assembly; else repeat steps 4-11.

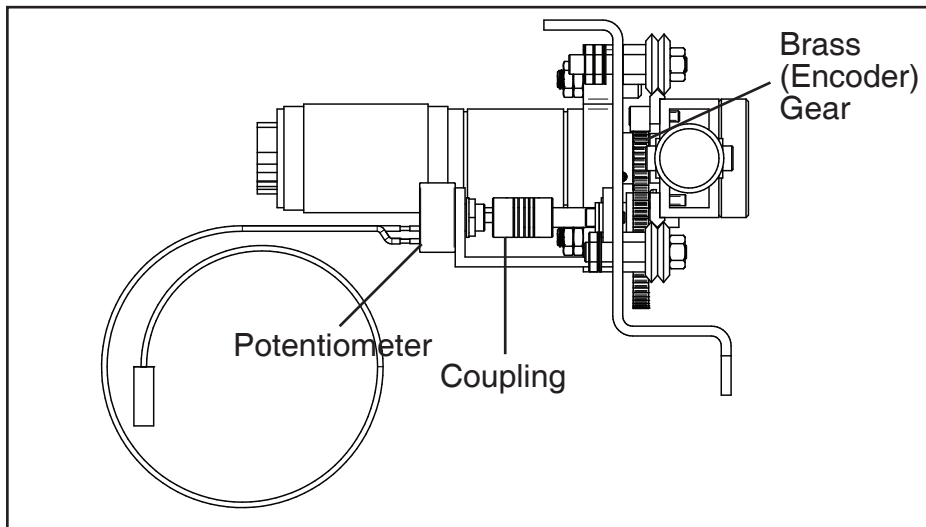
**Note:** Reference mark B will no longer apply if the potentiometer was changed in service or the cross arm was previously centered using the electrical method on page 32.

## SERVICE PROCEDURE: INSTALLING THE CROSS ARM (WPD-1150)

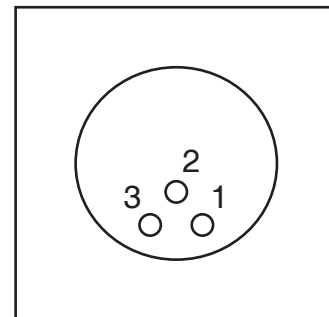
### OPTION 2 - The Electrical Way

Tools required: Ohm meter rated to at least 5k Ohm, flat screw driver, 3/32" hex key, tape measure or other measuring device.

1. Place machine on blocks to protect the drive pinion (underneath).
2. Remove Right Side Panel (BUG-5708) from the clutch side of the Drive Unit (BUG-5980).
3. If necessary, install the Cross Arm (WPD-1150). Insert from the brass gear side. Make sure the brass gear teeth and the V-guide teeth do not skip.
4. Center the cross arm. The V-guide will stick out of the machine by 4.25 in (110 mm) on each side when centered.
5. Loosen only the set screw on the gear side of the coupling between the brass encoder gear and the potentiometer. Refer to Figure 8.
6. Unplug wire harness leading from Potentiometer.
7. Using an Ohmmeter, measure resistance across Node 1 and Node 3 (refer to Figure 9). This should measure approximately 5000 ohms.
8. Rotate the Potentiometer until resistance across Node 1 and Node 2 is equal to resistance across Node 2 and Node 3, approximately 2500 ohms. The Potentiometer is now centered.
9. While being careful not to move the Potentiometer, secure the coupling to the gear shaft.
10. Plug wire harness from Potentiometer into proper terminal on the speed control board (CAS-1770).
11. Connect to power supply of appropriate voltage, turn machine ON and verify that Cross Arm is centered.
12. Install Right Side Panel.
13. If necessary, install Arm Stop (WPD-1164) and Height Slide Assembly (CAS-1500) to the end of the Cross Arm.



**Figure 8:** Simplified side view of machine with right cover (BUG-5708) removed.



**Figure 9:** Potentiometer nodes used in Steps 7 & 8.

## SPK-BUG-6550 120V UNIVERSAL BUG-O-MATIC W/AHC SPARE PARTS KIT / PARTS LIST

<u>PART NO.</u>	<u>QTY</u>	<u>DESCRIPTION</u>
BUG-5551-10-HD	1	10 FT CABLE ASSEMBLY, HD, SHIELDED
SPK-BUG-5755	1	SPARE PARTS, UNIV BOM PENDANT
SPK-BUG-5980	1	SPARE PARTS, 120VAC UNIV BOM
SPK-CAS-1500-1550	1	SPARE PARTS, CAS-1500 SERIES

## SPK-BUG-5755 SPARE PARTS, PENDANT / PARTS LIST

<u>PART NO.</u>	<u>QTY</u>	<u>DESCRIPTION</u>
BUG-1562	1	MULTI-TURN POTENTIOMETER
BUG-1572	1	POTENTIOMETER
BUG-2255	1	TOGGLE SWITCH
BUG-3297	6	KNOB, DIGITAL DIAL
BUG-5758	2	TOGGLE SWITCH SEAL, GRAY
BUG-5759	1	POT SHAFT SEAL 1/4" GRAY
BUG-5760-UB	1	CONTROL BOARD, UNIV BUGOMATIC
BUG-5761	1	TOGGLE SWITCH
BUG-5768	1	POT, 10 TURN, 100K
SWT-1111	1	NOR. OPEN PUSH BUTTON, BLACK
SWT-1112	1	N. O. PUSH BUTTON SWITCH RED
SWT-1113	1	N. O. PUSH BUTTON SWITCH GREEN

## SPK-BUG-5980 SPARE PARTS, 120VAC / PARTS LIST

<u>PART NO.</u>	<u>QTY</u>	<u>DESCRIPTION</u>
ARM-2279	1	TOGGLE SWITCH
BUG-1393	1	VOLT TRAP 120VAC
BUG-1770-UB	1	MOTOR CONTROL BOARD
BUG-2923	1	.7 AMP CIRCUIT BREAKER
BUG-2924	1	RESET SEAL, TRANSPARENT
BUG-5590	1	GEAR MOTOR
BUG-5591	1	PINION
CAS-1060-500	1	ARC SENSING CONTROL BOARD
CAS-1770-001	1	SPEED CONTROL (IRON ROTOR)
GOF-3014	1	DRIVE PINION W/ KEY SET SCREW
MPD-1028	4	FUSE, SLO-BLO, 4A
SWT-0503	1	SWITCH, TOGGLE, 4PDT
WPD-1045	1	BRAKE ASSEMBLY

## SPK-CAS-1500-1550 SPARE PARTS, CAS-1500 SERIES / PARTS LIST

<u>PART NO.</u>	<u>QTY</u>	<u>DESCRIPTION</u>
CAS-1553	1	CONNECTING CABLE HALL EFFECT
PCB-1213	1	HALL EFFECT INTERFACE BOARD

## **SPK-BUG-6552 240V UNIVERSAL BUG-O-MATIC W/AHC SPARE PARTS KIT / PARTS LIST**

<u>PART NO.</u>	<u>QTY</u>	<u>DESCRIPTION</u>
BUG-5551-10-HD	1	10 FT CABLE ASSEMBLY, HD, SHIELDED
SPK-BUG-5755	1	SPARE PARTS, UNIV BOM PENDANT
SPK-BUG-5982	1	SPARE PARTS, 240VAC UNIV BOM
SPK-CAS-1500-1550	1	SPARE PARTS, CAS-1500 SERIES

## **SPK-BUG-5982 SPARE PARTS, 240 VAC / PARTS LIST**

<u>PART NO.</u>	<u>QTY</u>	<u>DESCRIPTION</u>
ARM-2279	1	TOGGLE SWITCH
BUG-1563	1	VOLT TRAP 240VAC
BUG-1770-UB	1	MOTOR CONTROL BOARD
BUG-2924	1	RESET SEAL, TRANSPARENT
BUG-2952	1	.5 AMP CIRCUIT BREAKER
BUG-5590	1	COVER ASSEMBLY 120 VAC
BUG-5591	1	PINION
CAS-1060-500	1	ARC SENSING CONTROL BOARD
CAS-1770	1	SPEED CONTROL (IRON ROTOR)
GOF-3014	1	DRIVE PINION W/KEY SET SCREW
MPD-1028	4	FUSE, SLO-BLO, 4A
SWT-0503	1	SWITCH, TOGGLE, 4PDT
WPD-1045	1	BRAKE ASSEMBLY

## **SPK-BUG-6554 42V UNIVERSAL BUG-O-MATIC W/AHC SPARE PARTS KIT / PARTS LIST**

<u>PART NO.</u>	<u>QTY</u>	<u>DESCRIPTION</u>
BUG-5551-10-HD	1	10 FT CABLE ASSEMBLY, HD, SHIELDED
SPK-BUG-5755	1	SPARE PARTS, UNIV BOM PENDANT
SPK-BUG-5984	1	SPARE PARTS, 42VAC UNIV BOM
SPK-CAS-1500-1550	1	SPARE PARTS, CAS-1500 SERIES

## **SPK-BUG-5984 SPARE PARTS, 42 VAC / PARTS LIST**

<u>PART NO.</u>	<u>QTY</u>	<u>DESCRIPTION</u>
ARM-2279	1	TOGGLE SWITCH
BUG-1393	1	VOLT TRAP 120VAC
BUG-1770-UB	1	MOTOR CONTROL BOARD
BUG-2924	1	RESET SEAL, TRANSPARENT
BUG-2933	1	2 AMP CIRCUIT BREAKER
BUG-5590	1	GEAR MOTOR
BUG-5591	1	PINION
CAS-1060-500	1	ARC SENSING CONTROL BOARD
CAS-1770-001	1	SPEED CONTROL (IRON ROTOR)
GOF-3014	1	DRIVE PINION W/ KEY SET SCREW
MPD-1028	4	FUSE, SLO-BLO, 4A
SWT-0503	1	SWITCH, TOGGLE, 4PDT
WPD-1045	1	BRAKE ASSEMBLY

# BUG-O SYSTEMS INTERNATIONAL

## EU DECLARATION OF CONFORMITY

Manufacturer and technical  
documentation holder:

**BUG-O SYSTEMS INTERNATIONAL**  
a Division of Weld Tooling Corporation

Address:

280 Technology Drive  
Canonsburg, PA 15317-9564

Hereby declare that machinery:

**UNIVERSAL BUG-O-MATIC**, including options and accessories,  
**UNIVERSAL BUG-O-MATIC WITH AUTOMATED HEIGHT CONTROL  
(AHC)**, including options and accessories

Sales codes:

**BUG-6550, BUG-6552, BUG-6554, BUG-5700, BUG-5702, BUG-5704.**  
(sales codes may also contain prefixes and suffixes)

Is in conformity with Council Directives and amendments:

- 2006/42/EC – Machinery Directive.
- 2014/35/EU – Electromagnetic Compatibility (EMC) Directive
- 2011/65/EU – Restriction of the use of certain hazardous substances (RoHS)

Standards:

- EN 12100:2010 – Safety of Machinery – General principles for design – Risk assessment and risk reduction.
- EN 60204-1:2016 Safety of machinery – Electrical equipment of machines Part 1: General Requirements.
- EN 61000-6-2 Electromagnetic compatibility (EMC) – Part 6-2 Generic standards – Immunity for industrial environments.
- EN 61000-6-4 Electromagnetic compatibility (EMC) – Part 6-4 Generic standards – Emissions for industrial environments.
- EN 50581:2012 Technical documentation for the assessment of electrical and electronic products with respect to restriction of hazardous substances.

-The machinery, product, assembly or sub-assembly covered by this Declaration of Conformity must not be put into service until the machinery into which it is to be incorporated (if applicable) is declared in conformity with provisions of the applicable directives(s).

Authorized representative for the compilation of the relevant technical documentation and issuer of EC Declaration of Conformity:

Date of Issue: JUNE 25,2019

Place of issue: 280 Technology Drive, Canonsburg, PA 15317, USA

Typed Name of Authorized Person: MATTHEW W. CABLE - PRESIDENT

# WARRANTY

## Limited 3-Year Warranty

Model \_\_\_\_\_  
Serial No. \_\_\_\_\_  
Date Purchased: \_\_\_\_\_  
Where Purchased: \_\_\_\_\_

For a period ending one (1) year from the date of invoice, Manufacturer warrants that any new machine or part is free from defects in materials and workmanship and Manufacturer agrees to repair or replace at its option, any defective part or machine. HOWEVER, if the invoiced customer registers the Product Warranty by returning the Warranty Registration Card supplied with the product within 90 days of the invoice date, or by registering on-line at [www.bugo.com](http://www.bugo.com), Manufacturer will extend the warranty period an additional two (2) years which will provide three (3) total years from the date of original invoice to customer. This warranty does not apply to machines which, after Manufacturer's inspection are determined by Manufacturer to have been damaged due to neglect, abuse, overloading, accident or improper usage. All shipping and handling charges will be paid by the customer.

The foregoing express warranty is exclusive and Manufacturer makes no representation or warranty (either express or implied) other than as set forth expressly in the preceding sentence. Specifically, Manufacturer makes no express or implied warranty of merchantability or fitness for any particular purpose with respect to any goods. Manufacturer shall not be subject to any other obligations or liabilities whatsoever with respect to machines or parts furnished by Manufacturer.

Manufacturer shall not in any event be liable to Distributor or any customer for any loss of profits, incidental or consequential damages or special damages of any kind. Distributor's or customer's sole and exclusive remedy against Manufacturer for any breach of warranty, negligence, strict liability or any other claim relating to goods delivered pursuant hereto shall be for repair or replacement (at Manufacturer's option) of the machines or parts affected by such breach.

### Distributor's Warranty:

In no event shall Manufacturer be liable to Distributor or to any customer thereof for any warranties, representations or promises, express or implied, extended by Distributor without the advance written consent of Manufacturer, including but not limited to any and all warranties of merchantability or fitness for a particular purpose and all warranties, representations or promises which exceed or are different from the express limited warranty set forth above. Distributor agrees to indemnify and hold Manufacturer harmless from any claim by a customer based upon any express or implied warranty by Distributor which exceeds or differs from Manufacturer's express limited warranty set forth above.

### HOW TO OBTAIN SERVICE:

***If you think this machine is not operating properly, re-read the instruction manual carefully, then call your Authorized BUG-O dealer/distributor. If they cannot give you the necessary service, write or phone us to tell us exactly what difficulty you have experienced. BE SURE to mention the MODEL and SERIAL numbers.***