



DCW-18-L

SUBARC CIRCLE WELDER



412-331-1776 www.bugo.com

Bug-O Systems is guided by honesty, integrity and ethics in service to our customers and in all we do.





DCW-18-L Circle Welder

For welding diameters from 10" to 50"
(250 - 1270 mm) O.D.

Use with 3 jaw expandable chuck or manipulator

Features:

- Wire feeder with one set of drive rolls
- 1/12 HP P.M. motor and rational speed control
- 600 AMP gun & cable assembly
- 50 ft. (15 m) power cable
- 50 ft. (15 m) weld cable
- Quick disconnects for all cables
- Pre and post flow controls
- Wire reel adaptor for 60 lb. (27 kg) spools
- Adjustable vertical and horizontal torch positioning system
- Rise and fall cam assembly with 7" (177.8 mm) of travel
- Brushes and collector rings for welding current, rated at 600 AMPS 100% duty cycle
- Brushes and collector rings for all controls, eliminates cable and hose wrap

Technical Data:

DCW-18-L

| | |
|--------------------------|------------------------|
| Input Voltage: | 115 VAC |
| Amperage: | 0-600 amps |
| Voltage: | 0-50 volt |
| Wire Sizes: | 1/16"-5/32" (1.6-4 mm) |
| Rotation Speed: | .06-.72 rpm |
| Cam Range: | 0"-7" (0-175 mm) |
| Welding Diameter: | 10"-50" (254-1270 mm) |
| Height: | 43" (1092 mm) |
| Net Weight: | 530 lbs. (241 kg) |
| Shipping Weight: | 780 lbs. (355 kg) |

SIDE ELEVATION

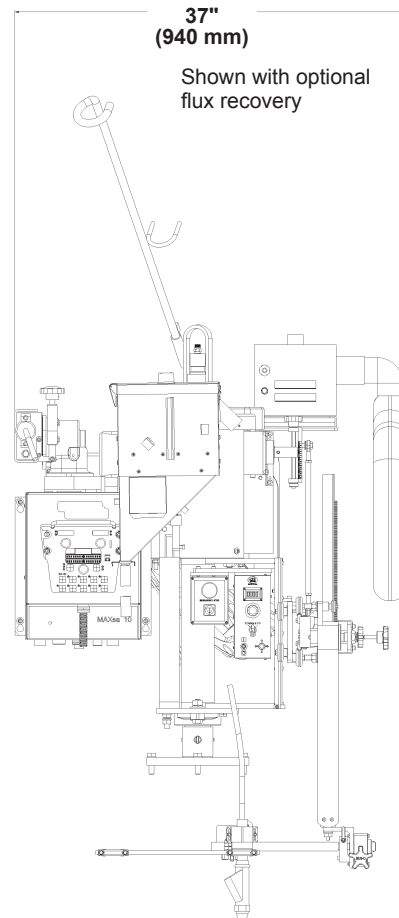

FRONT ELEVATION

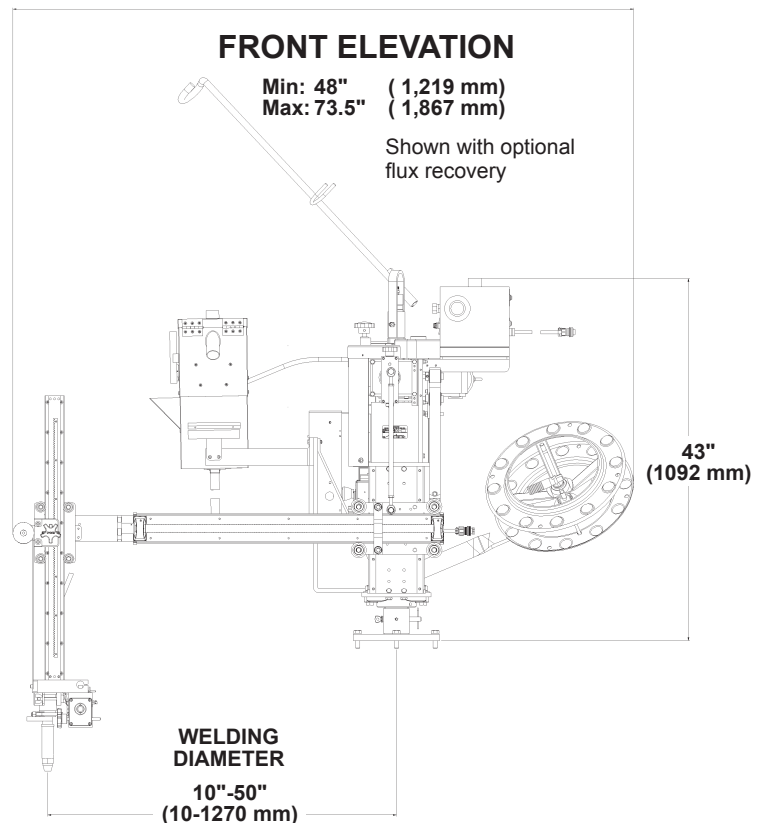



DCW-L Circle Welder

Power Wave® AC/DC 1000® SD

The Power Wave® AC/DC 1000® SD delivers Waveform Control Technology® to submerged arc welding. Choose constant current or constant voltage operation and set variable frequency and amplitude. Software-driven AC, DC positive or DC negative output allows the user to control the deposition rate and penetration. The result over conventional power sources is increased weld speeds, consistently higher quality welds and improved efficiencies in a single or multi-arc environment.

Processes

- DC+ Submerged Arc
- DC- Submerged Arc
- Balanced AC Submerged Arc
- Variable AC Submerged Arc



Power Wave® AC/DC 1000® SD Features

- **380 - 575 VAC, 50/60Hz Voltage Input** – Offers the ability to be connected anywhere in the world.
- **Voltage Compensation and Reliable Input Voltage Connection** – Provides consistent operation over $\pm 10\%$ input voltage variation.
- **No Hardware Reconfiguration Required with Easy Polarity Switching** – Eliminates downtime.
- **Easy to Parallel Machines or Run Multiple Arcs.**
- **3-Phase Voltage Input** – Eliminates the imbalance associated with transformer-based AC welding machines.
- **95% Power Factor Correction** – Enables connection of multiple machines on the same plant infrastructure for lower installation costs.
- **Severe Duty** – Can be stored outdoors. IP23 Rated.
- **ArcLink®, Ethernet, and DeviceNet™ Communication** – Offers remote process monitoring, control and troubleshooting.
- **True Energy™** – Measures, calculates and displays instantaneous energy in the weld for critical heat input calculations.
- **CheckPoint™** and Production Monitoring™ 2.2 – Use your server or our cloud-based server to view or analyze your welding data on almost any device – desktop, laptop, iPhone® or iPad®, Blackberry® and others. Track equipment usage, store weld data, configure fault limits and more.
- **Software Based Controls** – Can be upgraded as new features become available.
- **iARC™ Digital Control** - 90 times faster than the previous generation, delivering a responsive arc.
- **Factory Burn-In Tested** – At maximum output for 2 hours to ensure quality and reliability.

Power Wave® AC/DC 1000® SD Technical Specifications

| Product Name | Product Number | Input Voltage | Rated Output Current/Voltage/Duty Cycle | Input Current @ Rated Output | Output Range | Dimensions H x W x D in. (mm) | Net Weight lbs. (kg) |
|----------------------------|----------------|--------------------------------|---|------------------------------|--------------|---|----------------------|
| Power Wave® AC/DC 1000® SD | K2803-1 | 380/400/460/500 575/3/50/60 | 1000A/44V/100% | 82/79/69/62/55 | 100-1000A | 49.2 x 19.2 x 46.2 (1250 x 488 x 1174) | 800 (363) |



DCW-18-L Circle Welder

MAXsa® 10 Controller

ArcLink®-enabled Controller for Power Wave® AC/DC 1000® SD Systems

The MAXsa® 10 controller offers a single monitoring and control point for the entire hard automation welding system. Operators have full control over AC and DC welding parameters and easy PLC interfacing to control fixture travel, timers and other system commands.

Features

- **Severe Duty Ready** – The controller is IP23 rated and ready for operation in harsh environments.
- **Pendant Box** – Mount the controller in the standard protective box or remove the pendant for hand-held operation. Extend hand-held operation from 4 feet (1.2 m) up to 100 feet (30.5 m) with an ArcLink® extension cable.
- **Eight Procedure Memories** – Pre-set and save your optimal welding parameters for repeating applications and recall later for fast changeovers.
- **User-Friendly Controls** – Clear digital display and controls make it easy to set weld modes, AC operation, strike/start/end options, travel stop/start, timers and other parameters.
- **Limit Control** – Apply operator procedure limits or lockout on any or all parameters.
- **Waveform Control Technology®** – Allows the user to choose from a library of pre-programmed weld modes. Parameters for each mode can be adjusted within a limited range to achieve optimal balance between deposition rate and penetration.



Output
40 VDC

Input
40 VDC

Processes
Submerged Arc

MAXsa® 22 Feed Head

Submerged Arc Hard Automation Feed Head

Designed specifically for hard automation applications, the MAXsa® 22 Feed Head delivers accurate wire feeding of large diameter submerged arc wires. Based on Lincoln's proven gearbox and cast aluminum feedplate, the MAXsa® 22 model features a 40VDC permanent magnet, high torque motor that delivers plenty of traction to push up to 7/32 in. (5.6 mm) diameter solid wire. A top speed of up to 500 ipm (12.7 m/min) can be achieved by changing the gear ratio.

Features

- **Flexible Configuration** – Can be used in single, tandem, Twinarc® or multiple arc applications.
- **Closed Loop Speed Control** – Facilitates full control over starting, running and stopping wire feed speed.
- **IP23 Rated** – Tested to withstand harsh environments.
- **Additional Gear Sets included** – Used to change the speed ratio to match the requirements of your application.
- **Multi-Axis Rotation** – Rotational feed head adjustment in two planes allows flexible, accurate setup for fixturing or arc locating. Additional positioning flexibility can be achieved with optional horizontal and vertical lift adjusters.
- **Standard Accessories** – Including an adjustable wire straightener, cross-seam adjuster and electrical valve flux hopper and mounting bracket for TC-3 carriage.



Output
40 VDC

Input
40 VDC

Processes
Submerged Arc