

# INSTRUCTIONS AND PARTS MANUAL

## DIGITAL WEAVER KIT

**K-BUG 5000**

**K-BUG 5100**

**RIGID RAIL**

**HI-FLEX RAIL**

Please record your equipment identification information below for future reference. This information can be found on your machine nameplate.

Model Number \_\_\_\_\_

Serial Number \_\_\_\_\_

Date of Purchase \_\_\_\_\_

Whenever you request replacement parts or information on this equipment, always supply the information you have recorded above.

LIT-KBUG-5000-IPM-0423

Bug-O Systems is committed to empowering our customers by providing operator controlled mechanized solutions for their welding, cutting and custom applications.



**B U G - O   S Y S T E M S**

A DIVISION OF WELD TOOLING CORPORATION



280 TECHNOLOGY DRIVE    CANONSBURG, PENNSYLVANIA 15317-9564    USA  
PHONE: 412-331-1776    <https://www.bugo.com>    FAX: 412-331-0383

# SAFETY

**PROTECT YOURSELF AND OTHERS FROM SERIOUS INJURY OR DEATH. KEEP CHILDREN AWAY. BE SURE THAT ALL INSTALLATION, OPERATION, MAINTENANCE AND REPAIR PROCEDURES ARE PERFORMED ONLY BY QUALIFIED INDIVIDUALS.**



## **ELECTRIC SHOCK can kill.**

- 1) The equipment is not waterproof. Using the unit in a wet environment may result in serious injury. Do not touch equipment when wet or standing in a wet location.
- 2) The unused connectors have power on them. Always keep the unused connectors covered with the supplied protective panels. Operation of the machine without the protective panels may result in injury.
- 3) Never open the equipment without first unplugging the power cord or serious injury may result.
- 4) Verify the customer-supplied power connections are made in accordance with all applicable local and national electrical safety codes. If none exist, use International Electric Code (IEC) 950.
- 5) Never remove or bypass the equipment power cord ground. Verify the equipment is grounded in accordance with all applicable local and national electrical safety codes. If none exist, use International Electric Code (IEC) 950.

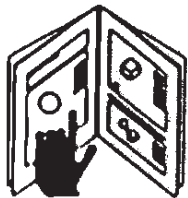

## **READ INSTRUCTIONS.**

Read the instruction manual before installing and using the equipment.



## **EQUIPMENT DAMAGE POSSIBLE.**

- 1) Do not plug in the power cord without first verifying the equipment is OFF and the cord input voltage is the same as required by the machine or serious damage may result.
- 2) Always verify both the pinion and wheels are fully engaged before applying power or equipment damage may occur.
- 3) Do not leave the equipment unattended.
- 4) Remove from the work site and store in a safe location when not in use.



## **FALLING EQUIPMENT can cause serious personal injury and equipment damage.**

Faulty or careless user installation is possible. As a result, never stand or walk underneath equipment.



## **MOVING PARTS can cause serious injury.**

- 1) Never try to stop the pinion from moving except by removing power or by using the STOP control.
- 2) Do not remove any protective panels, covers or guards and operate equipment.

## HIGH FREQUENCY WARNINGS

**SPECIAL PRECAUTIONS ARE REQUIRED WHEN USING PLASMA, TIG OR ANY WELDING PROCESS THAT USES HIGH FREQUENCY TO STRIKE AN ARC.**



**WARNING: HIGH FREQUENCY CAN EFFECT MACHINE OPERATION AND THEREFORE, WELD QUALITY.**

**Read the precautions below before installing and using the equipment.**

### **PRECAUTIONS:**

- 1) Some plasma or welding cables are strong sources of high frequency interference. NEVER lay a plasma or welding cable across the controls of the machine.
- 2) Always physically separate the plasma or welding cable leads from the machine cables. For example, the plasma or welding cable leads should NEVER be bundled with a pendant cable or the machine power cord. Maximize the separation between any machine cables and the plasma or welding cables.
- 3) Strictly follow the grounding procedures specified for the plasma or welding unit.  
NOTE: Some plasma and welding units produce exceptionally large amounts of high frequency noise. They may require a grounding rod be driven into the earth within six feet (2 meters) of the plasma or welding unit to become compatible with an automatic cutting or welding process.
- 4) If the high frequency is produced using a spark gap, adjust the points so the gap is as small as possible. The larger the gap, the higher the voltage and the higher the interference.
- 5) Some plasma or welding units will inject high frequency interference into the AC power line. Use separate power line branches whenever possible to power the plasma or welding source and the machine. Do not plug them into the same outlet box.
- 6) High frequency noise may enter the machine through the plasma or welding supply remote contactor leads. Some plasma and welding sources can produce noise spikes of up to several thousand volts. These sources are not compatible with automated cutting and welding equipment. It is recommended that the remote contactor leads on these plasma or welding sources not be connected to the machine. An alternate solution is to purchase a separate remote contactor isolation box.

# DIGITAL WEAVER KIT K-BUG 5000 / K-BUG 5100

## INSTRUCTIONS AND PARTS MANUAL TABLE OF CONTENTS

### PAGE

5	.....	Introduction
5	.....	Features
5	.....	Technical Data
5	.....	K-BUG 5000 / Dimensions
6	.....	K-BUG 5000 / Carriage and Rail
6	.....	K-BUG 5000 / Setup
7	.....	K-BUG 5100 / Dimensions
7	.....	K-BUG 5100 / Carriage and Rail
7	.....	K-BUG 5100 / Setup
8	.....	User Interface - Onboard Control Panel
9	.....	User Interface - Wireless Remote Control
9	.....	Enabling the Remote Control
10	.....	Parameter Settings
10	.....	Weave Selection / Show Mode
11	.....	Installation / Operation
11	.....	Cable Interconnect Diagram
12	.....	Maintenance
12	.....	Troubleshooting
13	.....	Troubleshooting, Cont'd.
14	.....	K-BUG 5000 Digital Weaver Kit / Exploded View / Parts List
15	.....	KBUG-5010 Standard Carriage / Exploded View / Parts List
16	.....	K-BUG 5100 Digital Weaver Kit / Exploded View / Parts List
17	.....	KBUG-5110 Hi-Flex Carriage / Exploded View / Parts List
18	.....	KBUG-5080 Weaver Assembly / Exploded View / Parts List
19	.....	K-BUG 5060/5062 Digital Drive Unit / Exploded View / Parts List
20	.....	K-BUG 5160/5162 Digital Drive Unit / Exploded View / Parts List
21	.....	K-BUG 5000 & K-BUG 5100 / Wiring Diagram
22	.....	SBG-450-__-__-__ Gun & Cable Assembly / Exploded View / Parts List
23	.....	Warranty

## INTRODUCTION

The Bug-O Digital Weaver delivers all position welding on rail; ideal for fillet or butt joints with flat or curved profiles. Weld parameters, including tractor speed, weave speed, weave width, dwell time, puddle build and crater fill are digitally controlled by the on-board control panel and the wireless remote. The Digital Weaver is available in two models: the K-BUG 5000 runs on BUG-O Heavy Duty Aluminum Rigid Rail or Semi-Flex Rail, and the K-BUG 5100 runs on BUG-O Hi-Flex Rail.

## FEATURES

- Wireless Remote Control
- Digital displays for weld speed, dwell times, weave width and weave speed
- Independent left, right dwell times
- Linear welding and four weave patterns available
- All weaving starts and ends in center position
- Rack and pinion drive; clutch

## TECHNICAL DATA

### Power Input

K-BUG 5000 / K-BUG 5100	120 VAC / 50-60 Hz / 1 Ph
K-BUG 5002 / K-BUG 5102	240 VAC / 50-60 Hz / 1 Ph

### Weight

K-BUG 5000 / K-BUG 5002	18 lb (8.2 kg)
K-BUG 5100 / K-BUG 5102	18 lb (8.2 kg)

Drive Motor	24 VDC, 12 W, 5000 RPM
Travel Speed	1.18 - 35 in/min (3 - 88 cm/min)
Torch Holder	Fits barrels up to 0.75 in (19 mm)
Torch Angle	adjustable
Running Angle	90° +/- 3°
Y-Stroke	2.05 in (52 mm)
Z-Stroke	1.69 in (43 mm)
Weave Speed*	to 188 in/min (to 4780 mm/min)
Weave Width*	to 1.05 in (to 26.7 mm)
Dwell Time	0 - 9.9 sec.

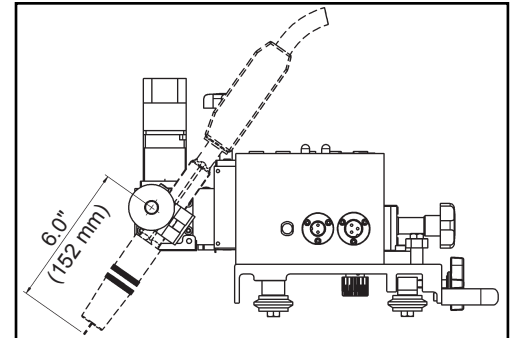

\* When Torch Pivot-to-Tip distance in 6.0 in (152 mm). Increasing Pivot-to-Tip distance will increase maximum weave speed and increase maximum weave width.

## K-BUG 5000

### DIMENSIONS

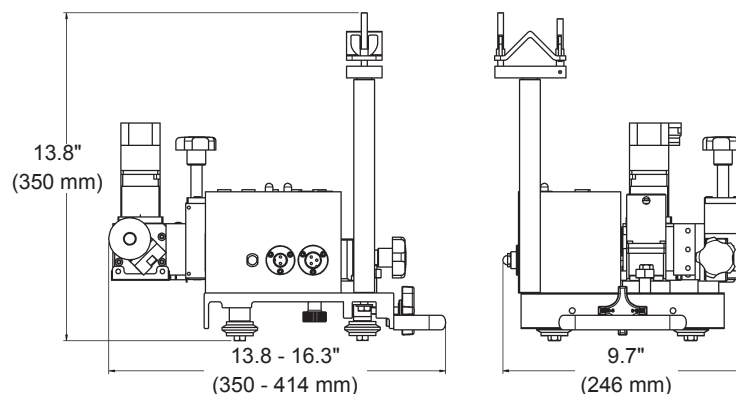

# K-BUG 5000, CONT'D.

## CARRIAGE AND RAIL

The K-BUG 5000 is a carriage mounted, rail driven, digitally controlled weaver. Its carriage is compatible with BUG-O Heavy Duty Aluminum Rigid Rail (ARR-1080 or ARR-1085) or Semi-Flex Rail (AFR-3000). Rigid Rail sections are available in 4 ft (1.18 m) and 8 ft (2.37 m) lengths and can be joined for longer spans. Semi-Flex Rail is available in 8 ft (2.37 m) sections, can be bent to minimum radius of 15 ft (5 m), and sections can be joined for longer spans. A variety of mounting options are available for the rail including on/off magnets, vacuum cups and permanent fixturing.

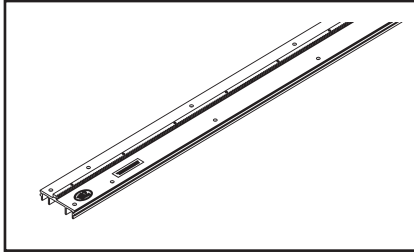

Figure 1: Aluminum Rigid Rail

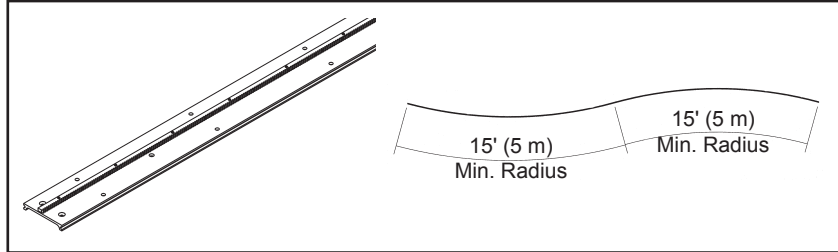

Figure 2: Semi-Flex Rail, for curved profiles with minimum radius of 15' (5 m).

## SETUP

### 1) POSITIONING THE MACHINE ON THE TRACK

Position the rail using magnet plates or vacuum cups. Wipe the track grooves free of weld splatter and other debris. This will prevent binding and premature rail and wheel wear. Lubricate the rack using a dry spray, if desired, for extended track life.

Turn the wheel engagement knob (A) on the side of the carriage fully counter clockwise to disengage the wheels. Then rotate the Master Drive clutch knob (B) fully counter clockwise to disengage the drive pinion. The carriage can now be placed anywhere on the track. Turn the wheel engagement knob (A) clockwise to engage the wheels firmly in the V-grooves. Verify all four wheels are in the grooves. Manually move the carriage along the track to verify the motion is smooth and the wheel alignment is correct. Rotate the Master Drive clutch knob (B) fully clockwise while gently rocking the machine forward and backward to fully engage the drive pinion. The rocking motion is necessary to help ensure proper gear mesh.

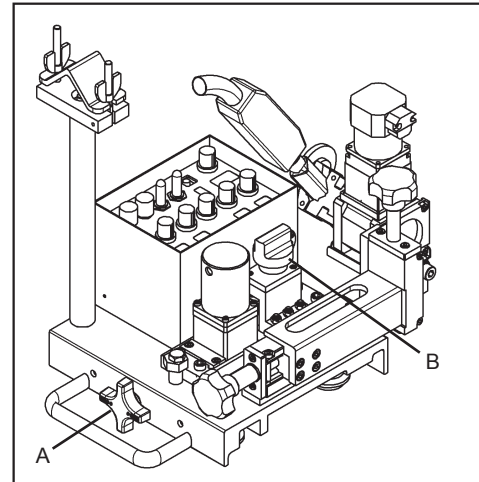

Figure 3: K-BUG 5000 Master drive clutch knob and wheel engagement knob.  
Note: Torch not included.

### 2) WHEEL ADJUSTMENT AND ALIGNMENT

Always check for proper carriage wheel adjustment before using the machine. With clutch disengaged, slide the carriage back and forth along the track. The carriage will move smoothly along the track if the wheels are properly aligned.

Grasp the sides of the carriage. The wheels are too loose if it is possible to move the carriage from side to side or up and down. Use a finger to keep one of the adjustable wheels from rotating as the carriage is manually pushed along the track. The wheels are adjusted too tight if firm finger pressure is not enough to prevent wheel rotation.

The wheels along one side of the carriage have stainless steel shim washers (C) underneath. These wheels are adjustable. Readjust these wheels, if necessary, by rotating the hex bolt (D) with a 1/2" wrench. Repeat the process for the other adjustable wheel. Engage clutch before welding.

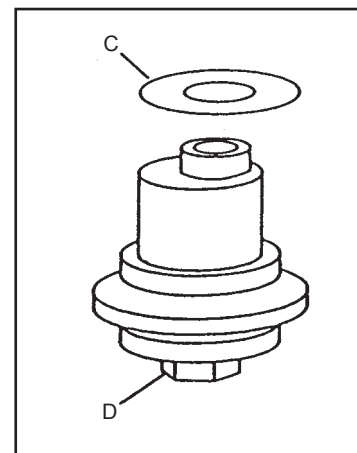
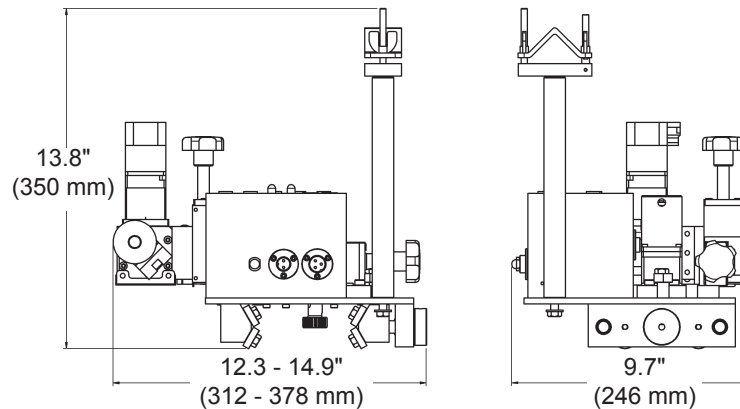

Figure 4: Adjustable Wheel  
(BUG-1984)

# K-BUG 5100

## DIMENSIONS



## CARRIAGE AND RAIL

The K-BUG 5100 is a carriage mounted, rail driven, digitally controlled weaver. Its carriage is only compatible with Bug-O Hi-Flex Rail (FMD-1050). This wear resistant rail comes in 57.7 in (1.47 m) lengths and can be held in place with vacuum cups or magnets. This rail can be used in straight applications or for bends down to 30 in (0.76 m) radius, in or out. Hi-flex rail can be used on compound curvatures and can be twisted 10° per 24 in (0.6 m) of length.

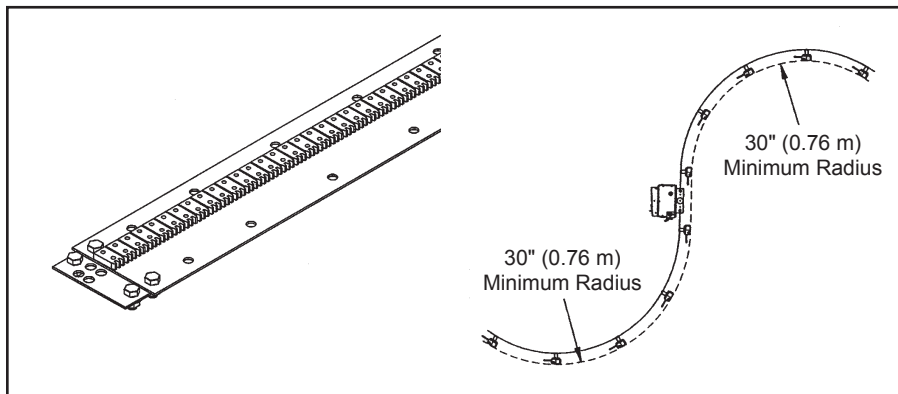

Figure 6: Hi-Flex Rail can be used flat or with bends down to 30" (0.76 m) radius.

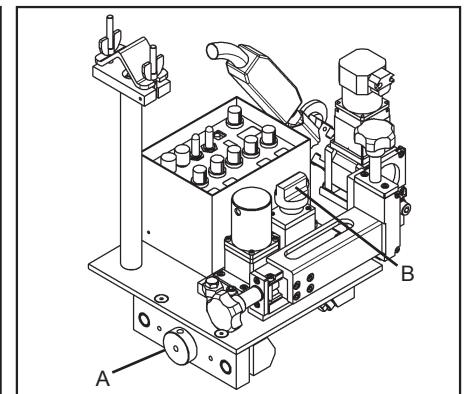

Figure 5: K-BUG 5100. Note: Torch not included.

## SETUP

### 1) POSITIONING THE MACHINE ON THE TRACK

Position the rail and secure using magnet plates or vacuum cups. Wipe track free of weld spatter and other debris. This will prevent binding and premature rail and wheel wear.

Turn the wheel engagement knob **(A)** on the side of the carriage fully counterclockwise to disengage the wheels. Then rotate the Master Drive clutch knob **(B)** fully counterclockwise to disengage the drive pinion. The carriage can now be placed anywhere on the track. Turn the wheel engagement knob **(A)** clockwise to engage the rail firmly in the V-groove of the bearing wheels. Verify all rail is aligned in the grooves formed by the wheels. Manually move the carriage along the track to verify the motion is smooth and the wheel alignment is correct. Rotate the Master Drive clutch knob **(B)** fully clockwise while gently rocking the machine forward and backward to engage the drive pinion. The rocking motion is necessary to help ensure proper gear mesh.

### 2) WHEEL ADJUSTMENT AND ALIGNMENT

The wheels on this carriage are factory set and are not adjustable.

## USER INTERFACE - ONBOARD CONTROL PANEL

The Digital Weaver can be controlled by the onboard control panel or by the wireless remote. The functions of the onboard control panel are described below.

1. **Travel Speed Adjustment Knob** - Rotate knob to adjust carriage travel speed. Turning clockwise (right) will INCREASE speed.
2. **Weave Selection Button** - Press this button to scroll through the available weave patterns and select the desired weave. The number in Display B indicates the selected weave pattern.
3. **Weld Contact Switch** - When switched to AUTO, the weld contact will close when the Start button is pushed and weld cycle will end when Stop button is pushed. When switched to OFF, the Start and Stop buttons will only control carriage travel.
4. **Travel Direction Switch** - Set switch to determine direction of carriage travel. Travel direction should be set *before* carriage travel is started.
5. **Start Button** - Push button to start carriage travel. Carriage will travel in the direction selected by the Travel Direction Switch. Weld contact will close if the Weld Contact Switch is set to AUTO.
6. **Stop Button** - Push button to stop carriage travel. If Weld Contact Switch is set to AUTO, torch will return to center and crater fill will be performed.
7. **Dwell Time Adjustment** - Increase or decrease dwell time by turning the adjustment knob. The outer knob controls the left dwell; the inner knob controls the right dwell. The range for these settings is 0 - 9.9 sec.
8. **Steering Knob** - Turn the knob clockwise to move the weave center to the right. Turn the knob counterclockwise to move the weld center to the left.
9. **Weave Width Adjustment Knob** - Increase the weave width by turning the knob clockwise; decrease by turning counterclockwise.
10. **Weave Speed Adjustment Knob** - Increase the weave speed by turning the knob clockwise; decrease by turning counterclockwise.

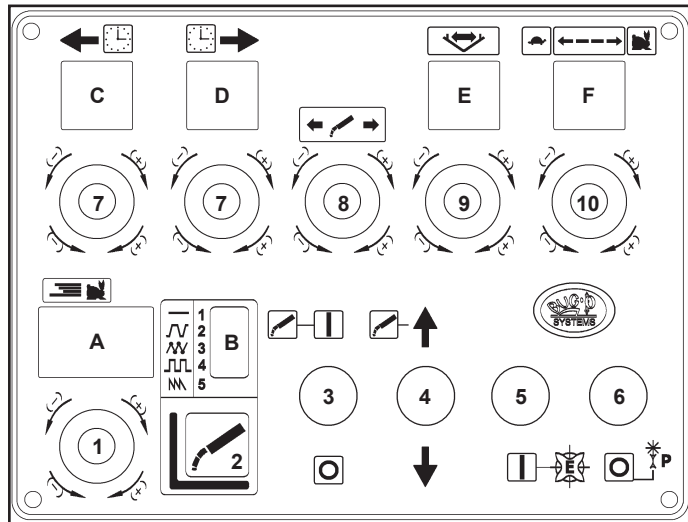

Figure 7: Onboard Control Panel Overview

The Control Panel also includes six digital displays. In addition to displaying real-time values during welding, the displays are used when setting parameters (as described on page 10).

DISPLAY INITIAL VALUES				
Display	Description	Range	Value	Unit
A	Travel Speed	0 - 850	50.0	in/min (cm/min)
B	Weave Selector	1 - 5	5	
C	Left Dwell	0.0 - 9.9	3	sec
D	Right Dwell	0.0 - 9.9	3	sec
E	Weaving Width	0 - 99	30	%
F	Weaving Speed	0 - 99	30	%

Note: The values shown above represent factory settings only. After first use, the machine will store and recall last known values as input by the operator.



## USER INTERFACE - WIRELESS REMOTE CONTROL

The Digital Weaver includes a wireless remote that can be used to control the machine. Magnets in the back of the remote allow for easy storage on the machine. The remote has a range of 33 ft (10 m). Each remote communicates at a unique frequency, allowing multiple machines to operate in close proximity without interference.

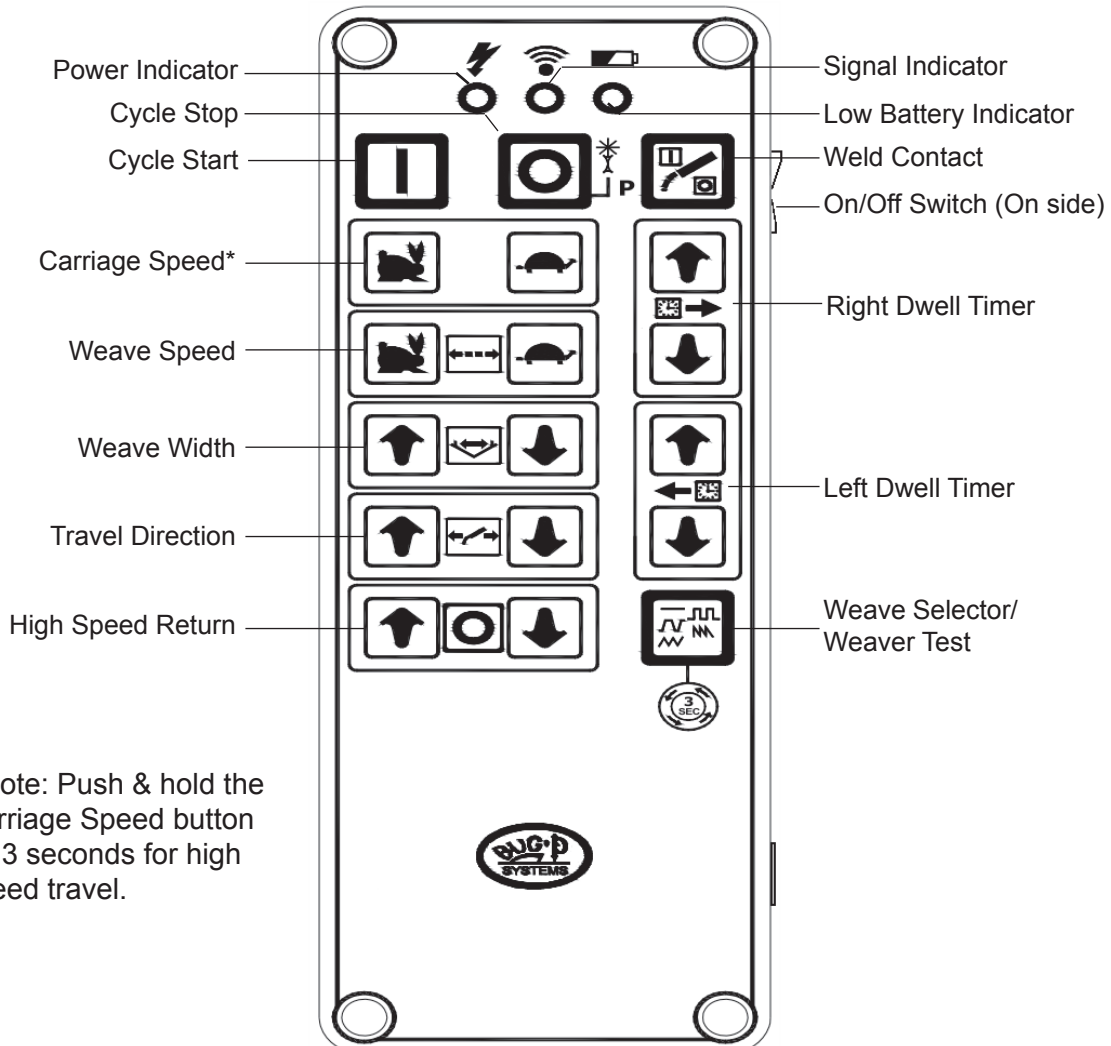

Figure 8: Remote Control Overview

The Remote features two unique functions:

1. **Weaver test** - Press and hold the Weave Selector for 3 seconds to test or jog the weaver.
2. **High Speed Return** - Press and hold the appropriate High Speed Return direction button for 3 seconds for high speed return. This is only available in the opposite direction of welding.

## ENABLING THE REMOTE CONTROL (SYNCING)

The remote is factory enabled. However, following certain maintenance activities, such as replacing the battery or Main PCB, it is necessary to enable the remote or establish communication between the remote and the machine.

1. Depress the orange Stop button on the Control Panel while plugging the machine into an AC power source of appropriate voltage.
2. Release Stop button on the Control Panel.
3. Press the Stop button on the Remote Control and turn ON the Remote. Continue to hold the Stop button for 3-5 seconds.
4. Release the Stop button on the Remote. The machine should reset and return to normal operating conditions.
5. Press the Start Button on the Remote to confirm it was set.
6. If the machine does NOT start, repeat steps 1-5.

NOTE: Once communication has been established between a remote and a machine, that remote will only work with that machine. It cannot be used to control any other K-BUG device.

## PARAMETER SETTINGS

Advanced welding parameters, like Puddle Build-up and Crater Fill are maintained in a hidden menu. The user must access this parameters menu to view and change these settings.

1. While holding down the Start button, plug the machine into an AC power source of appropriate voltage.
2. The active parameter (i.e. "n.0") will be displayed in the Left Dwell display. The current setting for the active parameter (i.e. "1.0") will be displayed in the Travel Speed display.
3. To adjust the parameter setting, turn the Travel Speed Adjustment knob. Turning to the right, or clockwise, will increase the value; counterclockwise will decrease the value.
4. Press and release the Start button to scroll through the parameters.
5. When finished setting (all) values, press the Stop button and unplug the machine.





Display	Description	Range	Default	Unit
n.0	Puddle Build-up	0.0 - 9.9	1	sec
n.1	Crater Fill	0.0 - 9.9	1	sec
n.2	Weave speed with Center Return	0 - 99	99	sec
n.3	Maximum Weave Width	0 - 90	5	Degree
n.4	Center Move Width	--	360	Degree
n.5*	Center Move Length	1 - 60	2	Pulse
n.6*	Diff Value of travelling speed	1 - 20	10	
n.7*	Signed data auto diff speed	1 - 7	7	
n.8	Motor emcy Auto Stop Time	0.0 - 9.9	3	sec
n.9*	Travel Motor Reducer Ratio	20 - 200	40	
n.a*	Weaving Motor Ratio	20 - 200	100	
n.b*	Travel Wheel Diameter	0.0 - 99.9	22.5	mm
n.c*	Demonstration Mode	On / Off	Off	
n.d	Operating Units	U1 / U2	U2	U1 (cm/min), U2 (in/min)

\* Indicates parameters that are NOT to be changed by the user.

NOTE: Adjusting some parameters, like Travel Motor Reducer Ratio (n.9) may effect machine performance and resulting weld quality.

## WEAVE SELECTION

The K-BUG 5000 and 5100 offer independent control of the drive and weave motors, allowing for five (5) automated weave patterns.

Symbol	Number	Name	Description
—	1	No Weave	Performs straight-line (linear) weld.
	2	Run	Tractor moves continuously -- during weave and dwell.
	3	Stop on Dwell	Tractor moves during weave and pauses on dwell.
	4	Step	Tractor pauses during the weave and travels during the dwell.
	5	Saw Tooth	Tractor pauses while weave moves <i>away</i> from tractor, then tractor moves while weave moves <i>toward</i> the tractor. Tractor pauses on dwell.

## SHOW MODE

During normal operation of the K-BUG 5000, Show Mode is OFF. The operator adjusts weld parameters as needed. When the machine is turned off, the last used parameters are saved. They are the initial values when the machine is turned on again. When Show Mode is ON, the operator still has the same control and weld abilities. However, the last used weld parameters ARE NOT saved during power-off. When the machine is restarted the initial weld parameters will be those preset by the factory.

# INSTALLATION AND OPERATION

1. Welding Preparation - Secure the necessary welding supplies
  - Welding Power Source
  - Wire Feeder
  - Shielding Gas, with pressure and flow regulators and appropriate fittings
  - Torch for gas shielded automated welding
  - Basic Weld Prep Tools
2. Install rail on work piece
  - Ensure clean surface at rail mounting points. Effectiveness of magnets or vacuum cups is reduced on dirty or irregular surface.
3. Install carriage on rail
  - Open carriage, slide on rail. Slide back & forth to align wheels.
  - Close carriage / engage clutch.
4. Welding Process
  - Plug machine into an A/C power source of appropriate voltage.
  - Insert torch and position torch for desired lead/lag angle to match the weld joint.
  - Position carriage so weld torch is at desired weld starting point.
  - Connect weld contact cable to machine, wire feeder and welding power source.
  - Set desired welding parameters - Weave Width, Dwell times, Weave type.
  - Verify adequate Shielding Gas Supply
  - Start Welding - Switch Weld Contact switch to AUTO, verify desired travel direction is set and travel speed is > 0 in/min and press Start button
  - Press Stop button when welding is complete. Turn Weld Contact switch to OFF.
  - Confirm Welding End.

## CABLE INTERCONNECT DIAGRAM

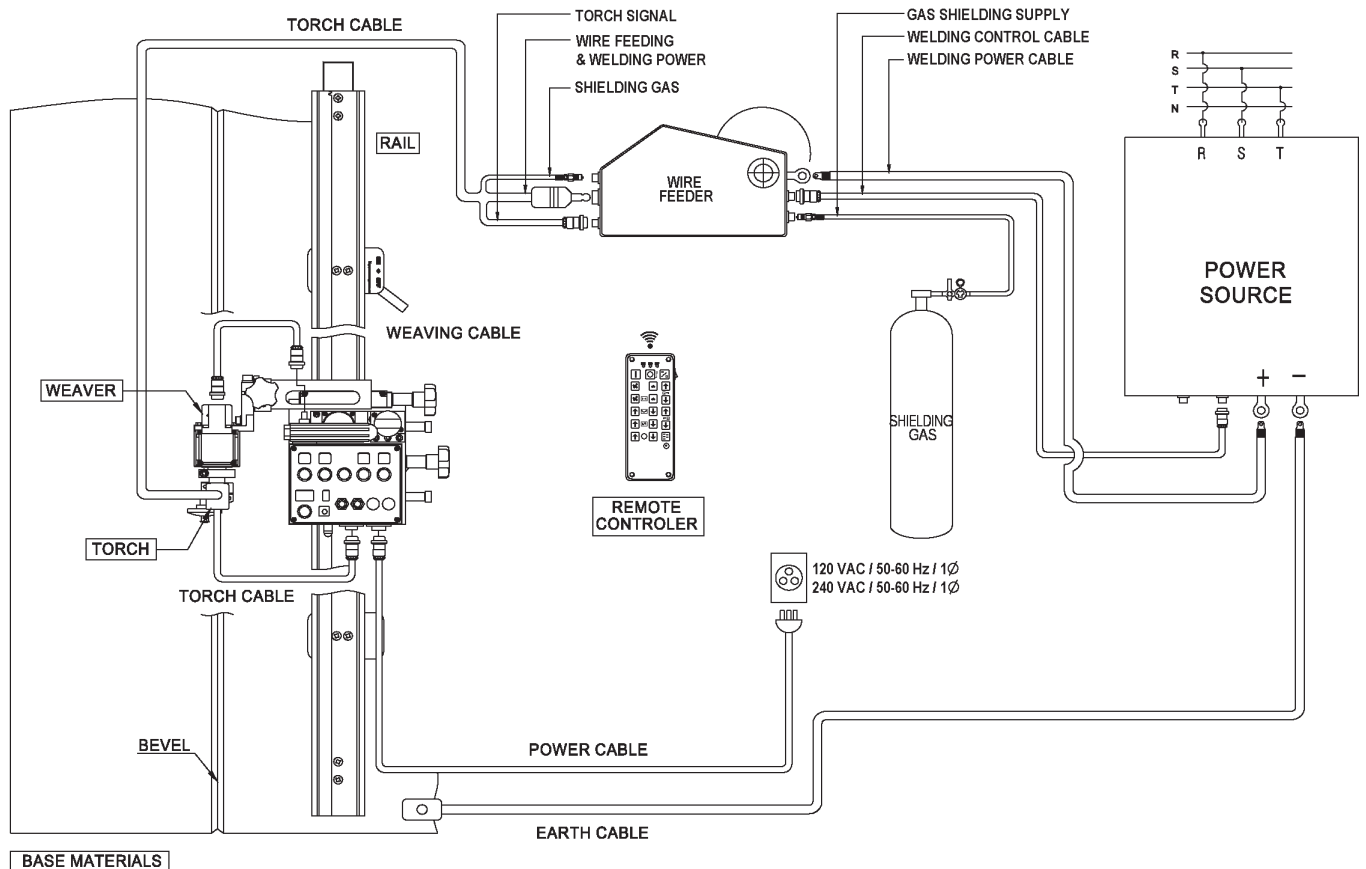

## MAINTENANCE

The K-BUG carriage should be periodically checked and cleaned to maximize service life.

### Before use:

Check all screws in the torch clamp and guide rollers. Tighten as needed. Loose fasteners may cause uneven travel or inconsistent weld quality.

### During use:

Monitor wheels, motors and welding torch for abnormal noise or overheating.

### After each use:

1. Clean control panel to remove dust and other debris.
2. Inspect carriage base, wheels, guide rollers, slide adjustment, magnets and torch for weld spatter or other debris. Clean as needed.
3. Inspect power cable and torch cable for cracked, cut or damaged insulation. Replace as needed.
4. Inspect connectors for damaged pins or loose connections. Replace as needed.

## TROUBLESHOOTING

Symptom	Cause	Repair
Control panel Display is not LIT	Disconnected Control Cable	Verify control cable is properly connected to machine.
	Faulty Control Cable	Replace cable.
	Control Box Fuse Tripped or Disconnected	Replace fuse. If problem persists, contact service rep.
No Arc when Start button is pressed	Weld Contact switch set to OFF	Turn Weld Contact switch to AUTO.
	Loose contact of Welding Leads	Check ground connections. Verify good contact on clean, unpainted surface.
	Bad or incorrectly wired Weld Contact switch	Check Wiring. Replace switch, if needed.
Carriage does not travel when Start button is pushed	Drive clutch not engaged	Verify drive pinion is engaged on rail. Verify carriage is properly installed on rail.
	Faulty or incorrectly wired Start button	Check Wiring. Repair as needed.
	Faulty Main PCB	Replace PCB.
Torch targets wrong position	Loose fastener on Torch Clamp or Torch Adjustment Slider	Check and tighten screws, replace if needed.
Slide is hard to adjust	Dust or other debris on slide parts	Clean slide parts. Lubricate with light oil.
Carriage stops during automatic welding	Obstacle in carriage path	Remove obstacles.
	Power cord disconnected	Verify cord routing and reconnect.
Arc continues after Stop button is pressed	Crater Fill timer has not timed out.	Check timer settings and adjust if needed.
	Faulty or incorrectly wired Stop button	Check Wiring. Repair as needed.

## TROUBLESHOOTING, CONT'D.

### K-BUG ERROR LIST

NO.	SYMPTOM	CAUSE	SOLUTION
E-03	Motion Stop	Main PCB EET ROM Error	Main PCB Replacement
E-05	Travelling Stop	Auto-Stop Travelling Motor may be overloaded / shorted	Push and release Stop Button  IF UNRESOLVED: 1. Check for loose wiring connection at drive motor and weave motor if equipped (see below). 2. Replace motor or motor reducer 3. Replace main PCB

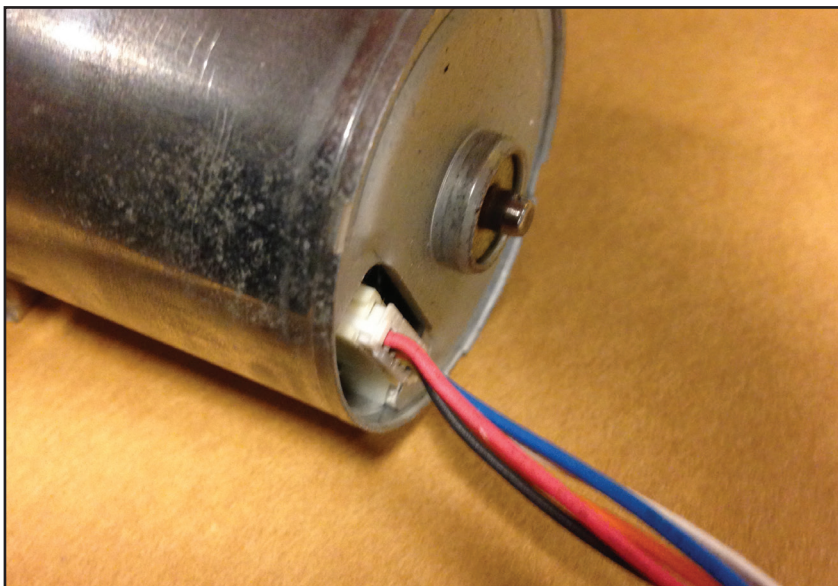
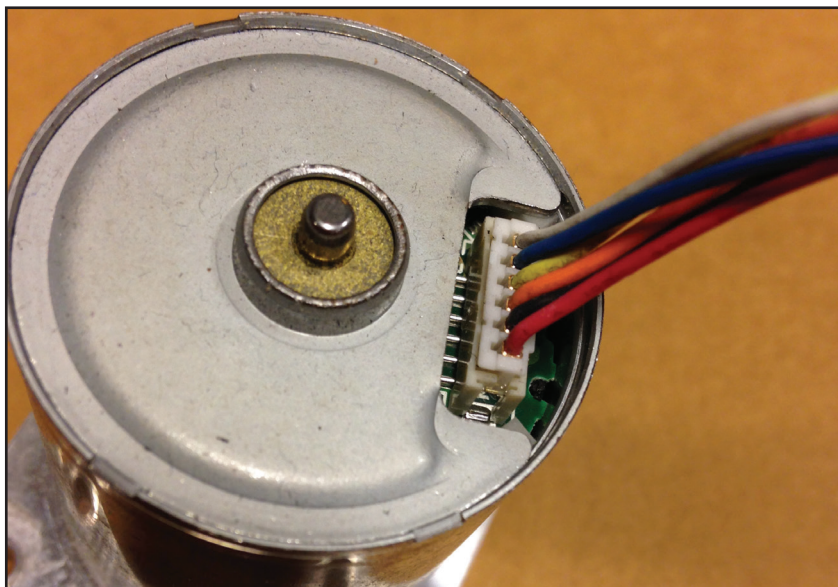

# K-BUG 5000 DIGITAL WEAVER KIT / EXPLODED VIEW / PARTS LIST

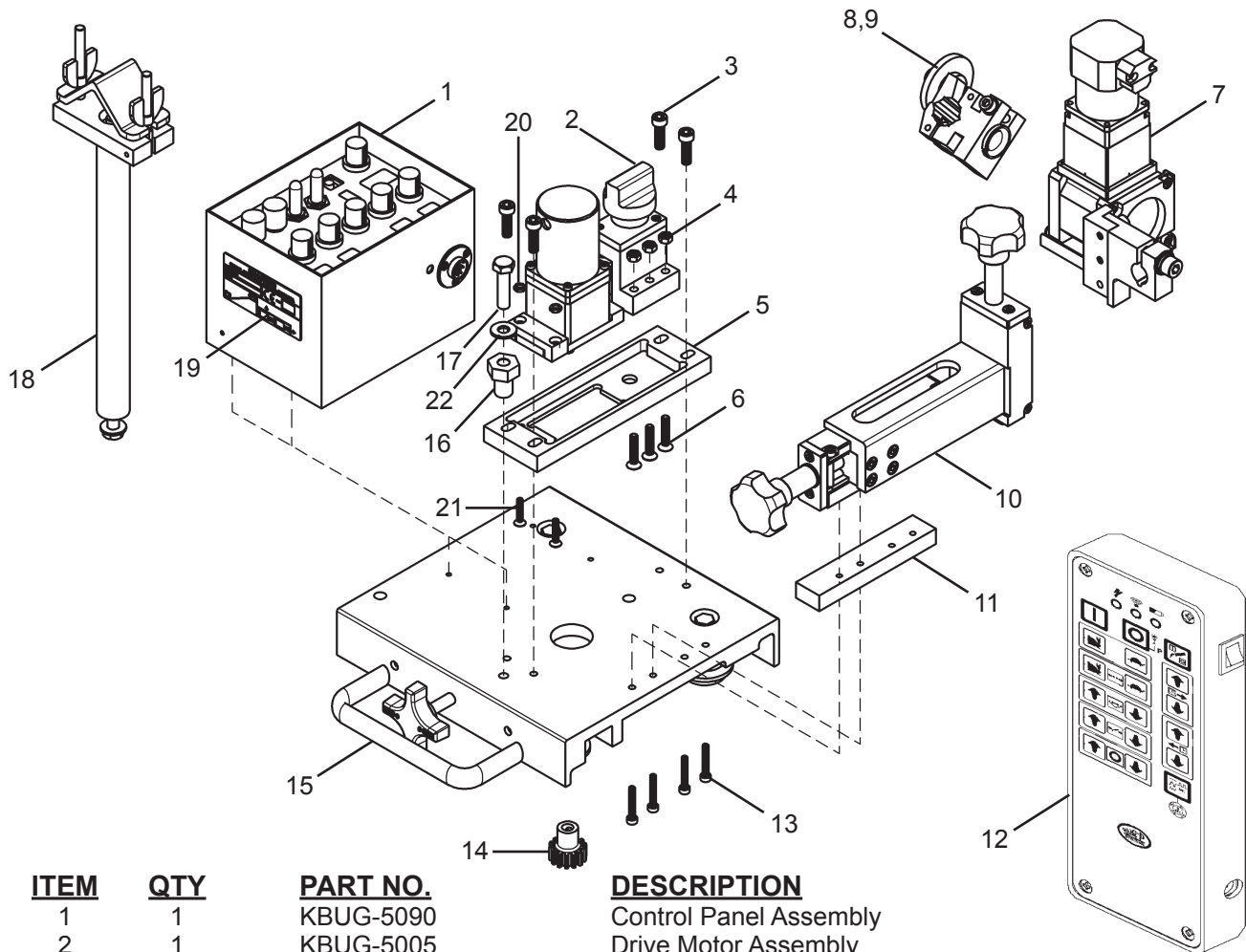

<u>ITEM</u>	<u>QTY</u>	<u>PART NO.</u>	<u>DESCRIPTION</u>
1	1	KBUG-5090	Control Panel Assembly
2	1	KBUG-5005	Drive Motor Assembly
3	4	MET-0579-SS	Screw, Soc Hd Cap, M6 x 20
4	3	MET-1360-SS	Hex Nut, M5
5	1	KBUG-5112	Motor Spacer
6	3	MET-2962-SS	Screw, Flt Hd Soc, M5 x 25
7	1	KBUG-5080	Weaver Assembly
8	1	KBUG-3120	Torch Clamp Assembly
9	1	KBUG-3076	Bushing
10	1	KBUG-5040	X-Z Slide Assembly
11	1	KBUG-5014	X-Slide Assembly Spacer
12	1	KBUG-3100	Wireless Remote Controller
13	4	MET-2552-SS	Screw, Soc Hd Cap, M4 x 25
14	1	KBUG-5113	Pinion
15	1	KBUG-5010	Standard Carriage
16	1	CWO-4325	BX3 Adjustable Bushing
17	1	FAS-2372-SS	Screw, Hex Hd Cap, 5/16-18 x 1-1/4
18	1	BUG-2668	Cable Anchor Bracket
19	1	BUG-1338	Name Plate
20	2	MET-1350-SS	M4 Hex Nut (SS)
21	2	MET-0959-SS	Flt Hd Soc Scr M4 x 20
22	1	WAS-0250	5/16 SAE Washer
*	1	KBUG-2273-15	Weld Contact Cable, 15 ft (4.6 m)
*	1	KBUG-2274-15**	Power Cable, 120V, 15 ft (4.6 m)
*	1	KBUG-5007	Weaver Cable Assembly
*	1	KBUG-5006	Motor Cable Assembly
*	1	KBUG-3092**	Remote Charger Cable, 120 V / 50-60 Hz / 1 Ph
*	4	MET-0552-SS	Soc Hd Cap Scr M4 x 8
*	4	WAS-5551-SS	5/16 SAE Washer

\* Not Shown

\*\* Note: For K-BUG 5002 (240V model), Power Cable is KBUG-2272-15 and Remote Charger is KBUG-3093.

# KBUG-5010 STANDARD CARRIAGE / EXPLODED VIEW / PARTS LIST

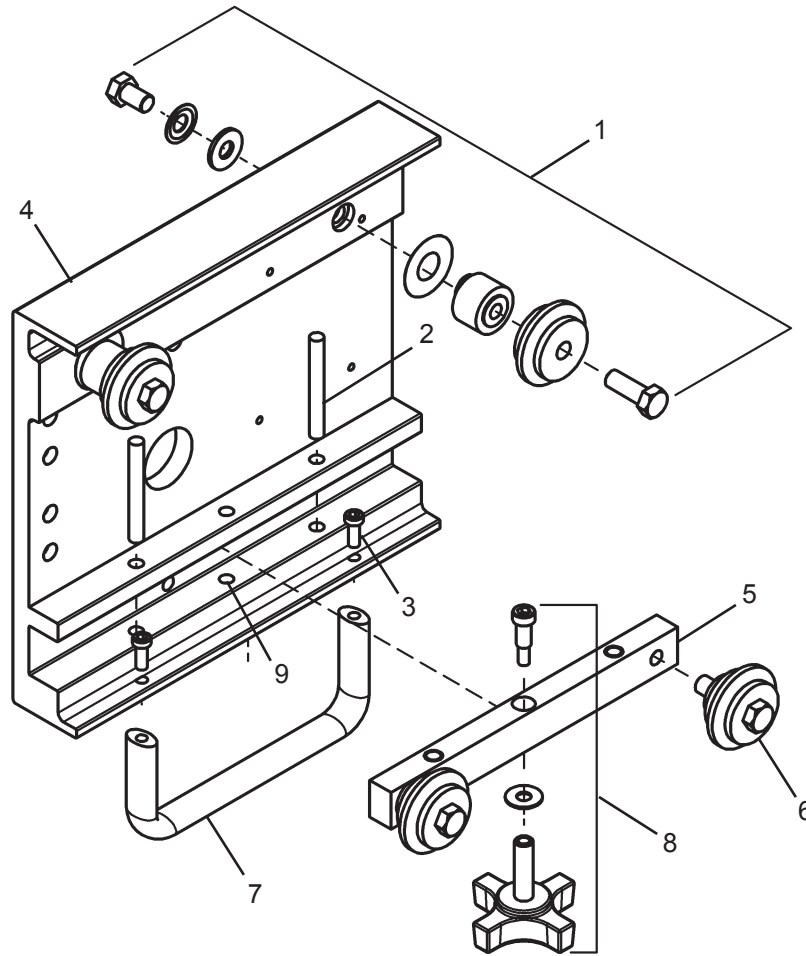

<u>ITEM</u>	<u>QTY</u>	<u>PART NO.</u>	<u>DESCRIPTION</u>
1	2	BUG-1984	Adjustable Wheel & Leg Assembly
2	2	BUG-5912	Dowel Pin
3	2	FAS-0545	Screw, Soc Hd Cap, 10-32 x 1/2
4	1	KBUG-5011	Standard Carriage Body
5	1	KBUG-5012	Slide Bar Assembly
6	2	MPD-1045	Fixed Wheel & Leg Assembly
7	1	MPD-1049	Handle
8	1	MPD-1059	Knob Assembly
9	1	MPD-1064	Bearing Plate

# K-BUG 5100 DIGITAL WEAVER KIT / EXPLODED VIEW / PARTS LIST

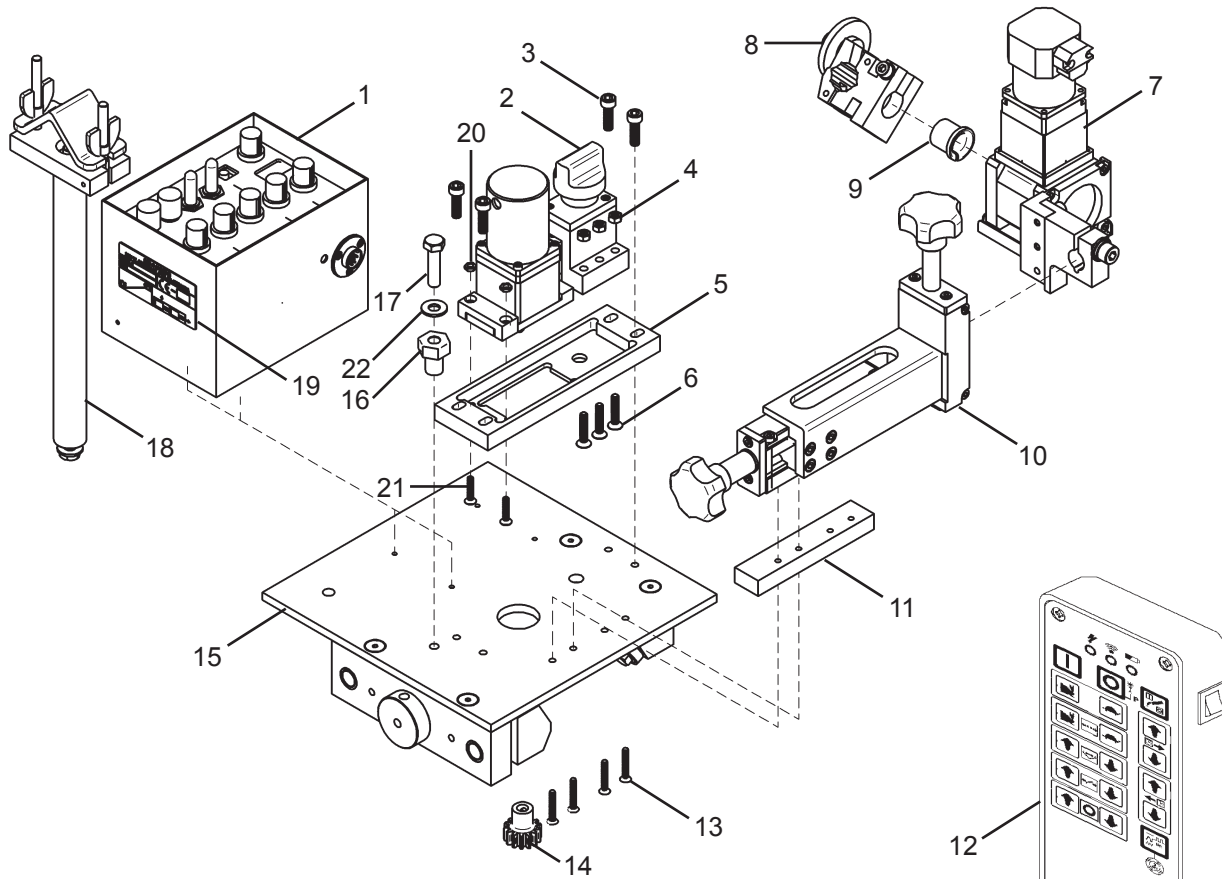

<u>ITEM</u>	<u>QTY</u>	<u>PART NO.</u>	<u>DESCRIPTION</u>
1	1	KBUG-5090	Control Panel Assembly
2	1	KBUG-5005	Drive Motor Assembly
3	4	MET-0579-SS	Screw, Soc Hd Cap, M6 x 20
4	3	MET-1360-SS	Hex Nut, M5
5	1	KBUG-5112	Motor Spacer
6	3	MET-2962-SS	Screw, Flt Hd Soc, M5 x 25
7	1	KBUG-5080	Weaver Assembly
8	1	KBUG-3120	Torch Clamp Assembly
9	1	KBUG-3076	Bushing
10	1	KBUG-5040	X-Z Slide Assembly
11	1	KBUG-5014	X-Slide Assembly Spacer
12	1	KBUG-3100	Wireless Remote Controller
13	4	MET-2552-SS	Screw, Soc Hd Cap, M4 x 25
14	1	KBUG-5113	Pinion
15	1	KBUG-5110	Standard Carriage
16	1	CWO-4325	BX3 Adjustable Bushing
17	1	FAS-2372-SS	Screw, Hex Hd Cap, 5/16-18 x 1-1/4
18	1	BUG-2668	Cable Anchor Bracket
19	1	BUG-1338	Name Plate
20	2	MET-1350-SS	M4 Hex Nut
21	2	MET-0959-SS	Flt Hd Soc Scr M4 x 20
22	1	WAS-0250	5/16 SAE Washer
*	1	KBUG-2273-15	Weld Contact Cable, 15 ft (4.6 m)
*	1	KBUG-2274-15**	Power Cable, 120V, 15 ft (4.6 m)
*	1	KBUG-5006	Weaver Cable Assembly
*	1	KBUG-5007	Motor Cable Assembly
*	1	KBUG-3092**	Remote Charger Cable, 120 V / 50-60 Hz / 1 Ph
*	4	MET-0552-SS	Soc Hd Cap Scr M4 x 8
*	4	WAS-5551-SS	5/16 SAE Washer

\* Not Shown

16 \*\* Note: For K-BUG 5102 (240V model), Power Cable is KBUG-2272-15 and Remote Charger is KBUG-3093.



# KBUG-5110 HI-FLEX CARRIAGE / EXPLODED VIEW / PARTS LIST

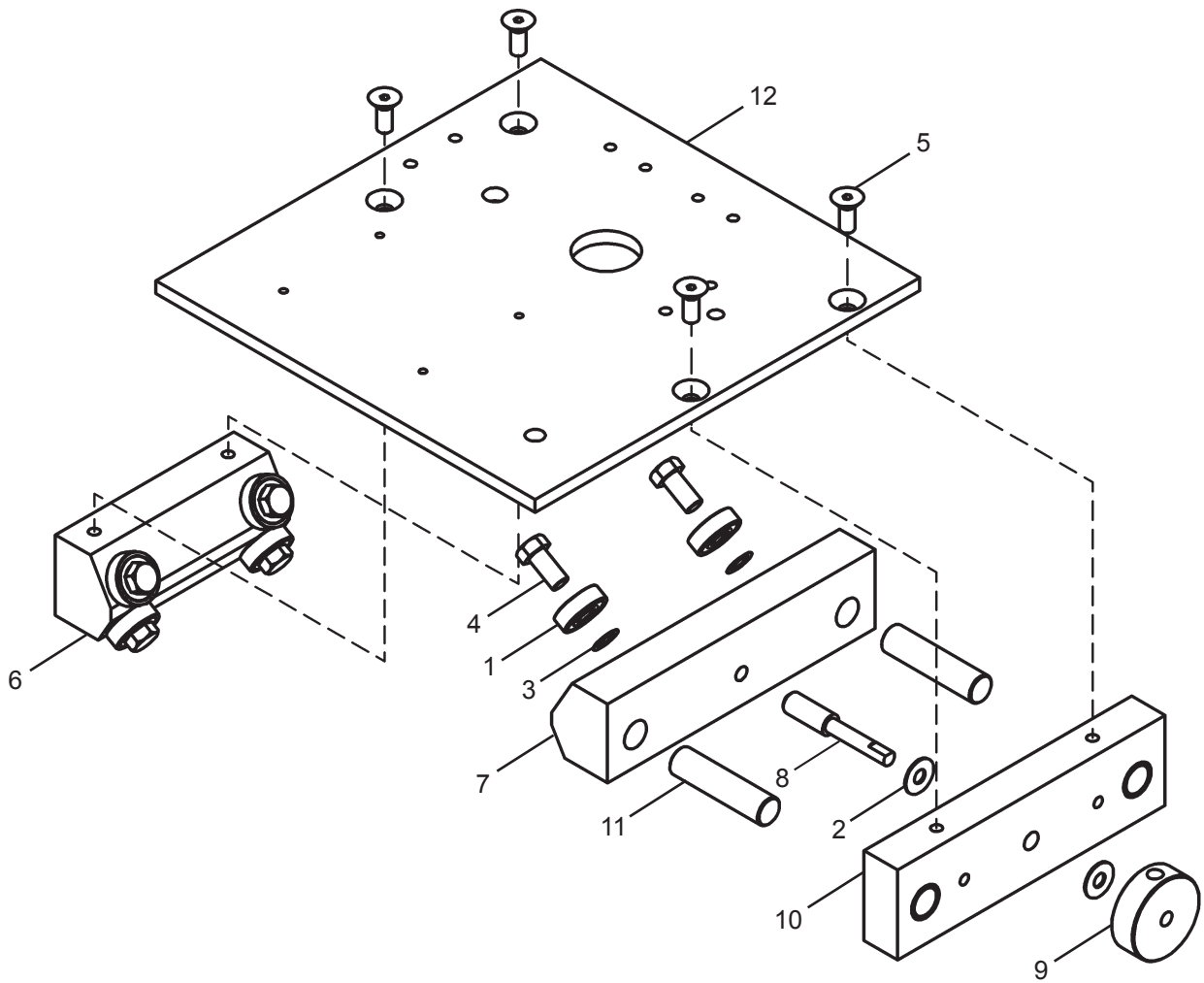

<u>ITEM</u>	<u>QTY</u>	<u>PART NO.</u>	<u>DESCRIPTION</u>
1	8	BUG-2012	Bearing
2	2	BUG-2848	Cam Spacer
3	8	CON-1029	Washer, 5/16 x 0.15
4	8	FAS-0386	Screw, Hex Hd Cap, 5/16-24 x 5/8
5	4	FAS-0956	Screw, Flat Hd Soc, 1/4-20 x 5/8
6	1	FMD-1068	Fixed Wheel Mounting Block
7	1	FMD-1069	Adj Wheel Mounting Block
8	1	FMD-1071	Threaded Shaft
9	1	FMD-1072	Knob
10	1	FMD-1081	Bearing Block
11	2	FMD-1083	Dowel Pin, 1/2 x 2"
12	1	KBUG-5111	Hi-Flex Carriage Top Plate

# KBUG-5080 WEAVER ASSEMBLY / EXPLODED VIEW / PARTS LIST

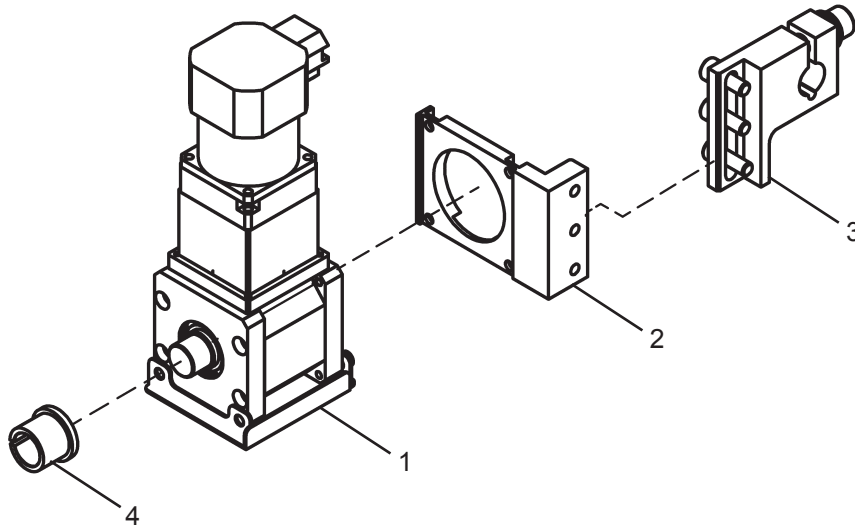

<u>ITEM</u>	<u>QTY</u>	<u>PART NO.</u>	<u>DESCRIPTION</u>
1	1	KBUG-3070	Weaver Motor Assembly
2	1	KBUG-5088	Weaving Bracket
3	1	KBUG-5089	Weaving Slide Clamp
4	1	KBUG-3076	Micarta Bushing

# K-BUG 5060/5062 DIGITAL DRIVE UNIT / EXPLODED VIEW / PARTS LIST

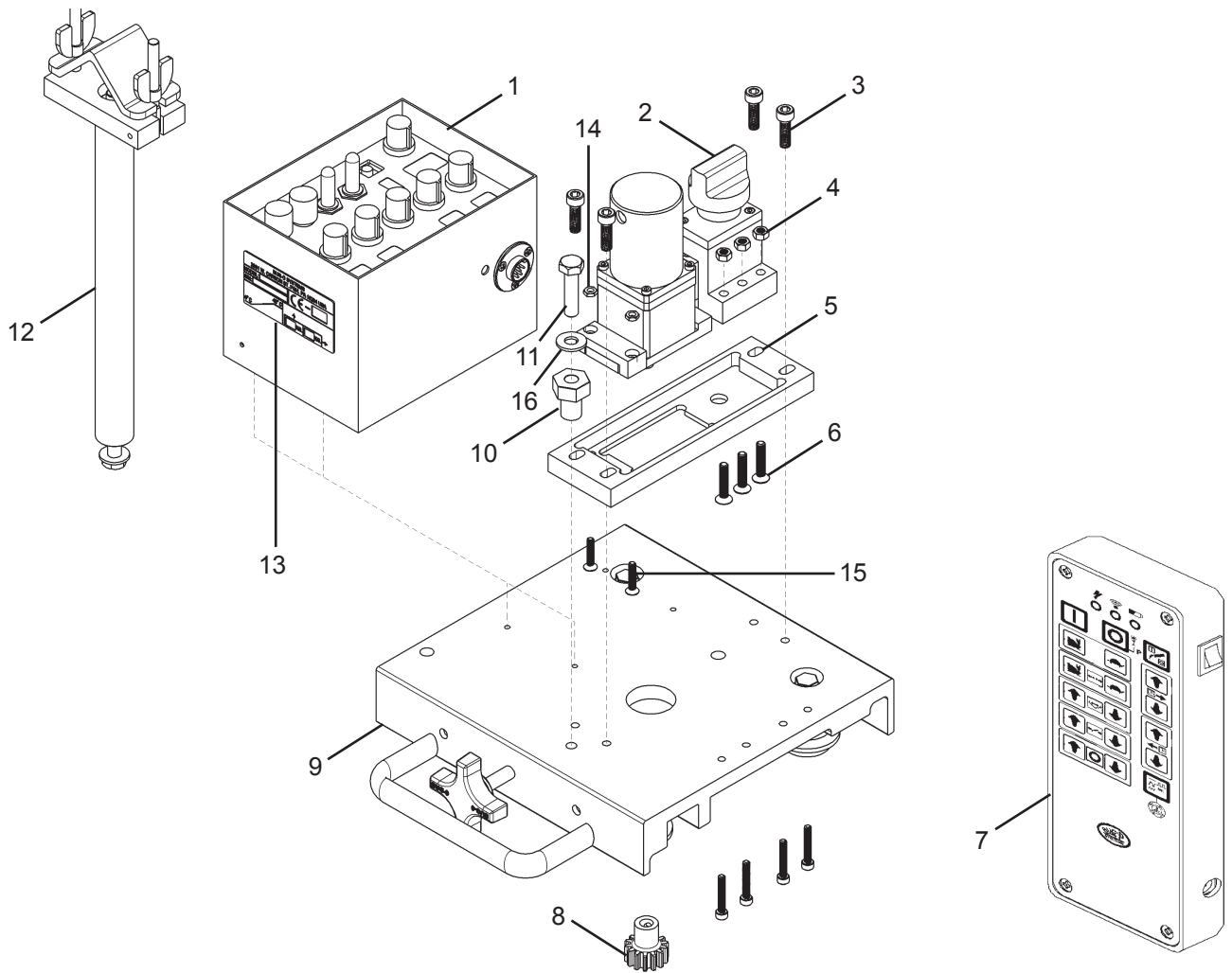

<b>ITEM</b>	<b>QTY</b>	<b>PART NO.</b>	<b>DESCRIPTION</b>
1	1	KBUG-5090	Control Panel Assembly
2	1	KBUG-5005	Drive Motor Assembly
3	4	MET-0579-SS	Screw, Soc Hd Cap, M6 x 20
4	3	MET-1360-SS	Hex Nut, M5
5	1	KBUG-5112	Motor Spacer
6	3	MET-2962-SS	Screw, Flt Hd Soc, M5 x 25
7	1	KBUG-3100	Wireless Remote Controller
8	1	KBUG-5113	Pinion
9	1	KBUG-5010	Standard Carriage
10	1	CWO-4325	BX3 Adjustable Bushing
11	1	FAS-2372-SS	Screw, Hex Hd Cap, 5/16-18 x 1-1/4
12	1	BUG-2668	Cable Anchor Bracket
13	1	BUG-1338	Name Plate
14	2	MET-1350-SS	M4 Hex Nut
15	2	MET-0959-SS	Flt Hd Soc Scr M4 x 20
16	1	WAS-0250	5/16 SAE Washer
*	1	KBUG-2273-15	Weld Contact Cable, 15 ft (4.6 m)
*	1	KBUG-2274-15**	Power Cable, 120V, 15 ft (4.6 m)
*	1	KBUG-5007	Motor Cable Assembly
*	1	KBUG-3092**	Remote Charger Cable, 120 V / 50-60 Hz / 1 Ph
*	4	MET-0552-SS	Soc Hd Cap Scr M4 x 8
*	4	WAS-5551-SS	5/16 SAE Washer

\* Not Shown

\*\* Note: For K-BUG 5002 (240V model), Power Cable is KBUG-2272-15 and Remote Charger is KBUG-3093.

# K-BUG 5160/5162 DIGITAL DRIVE UNIT / EXPLODED VIEW / PARTS LIST

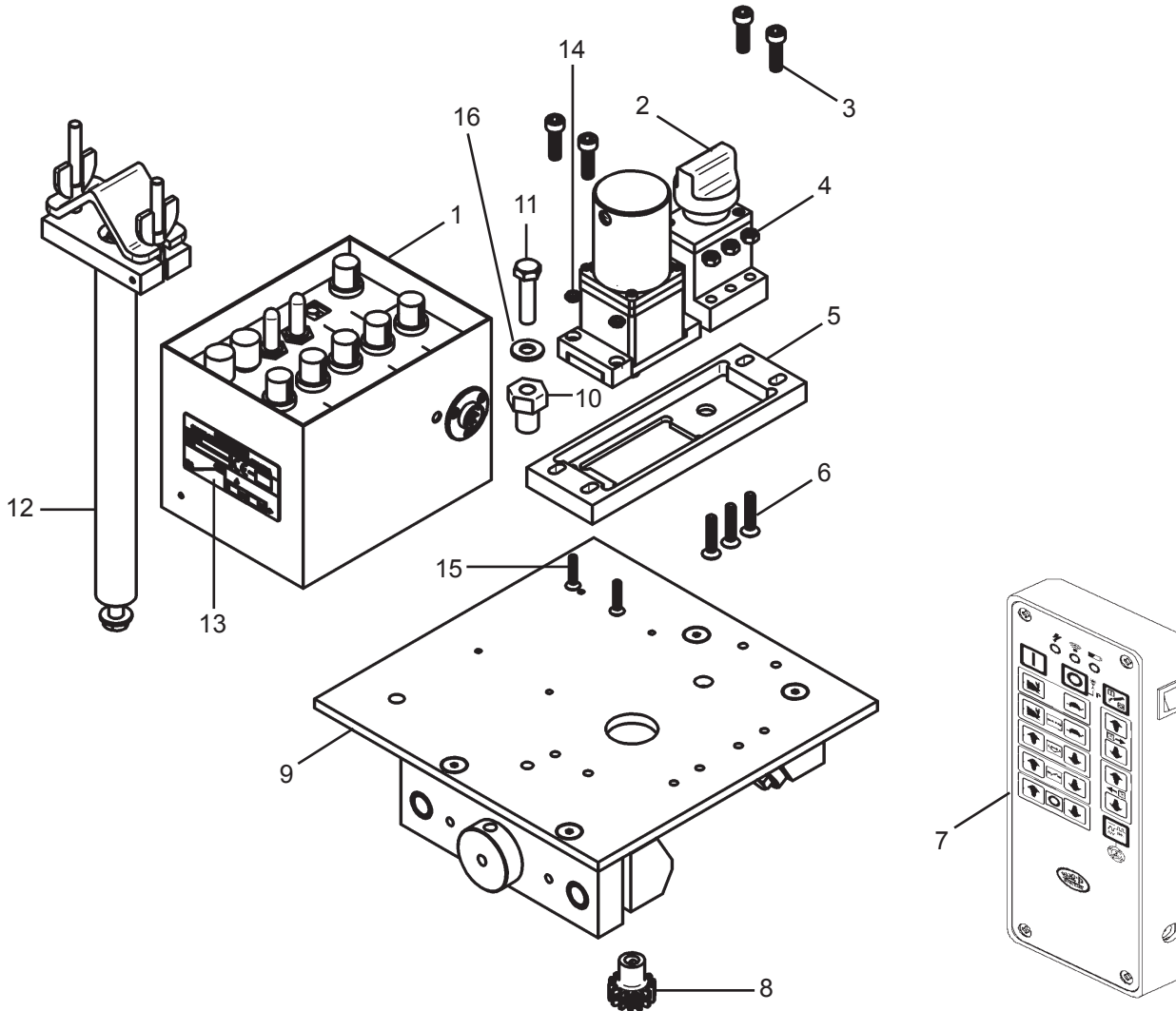

<u>ITEM</u>	<u>QTY</u>	<u>PART NO.</u>	<u>DESCRIPTION</u>
1	1	KBUG-5090	Control Panel Assembly
2	1	KBUG-5005	Drive Motor Assembly
3	4	MET-0579-SS	Screw, Soc Hd Cap, M6 x 20
4	3	MET-1360-SS	Hex Nut, M5
5	1	KBUG-5112	Motor Spacer
6	3	MET-2962-SS	Screw, Flt Hd Soc, M5 x 25
7	1	KBUG-3100	Wireless Remote Controller
8	1	KBUG-5113	Pinion
9	1	KBUG-5110	K-Bug Hi-Flex Carriage
10	1	CWO-4325	BX3 Adjustable Bushing
11	1	FAS-2372-SS	Screw, Hex Hd Cap, 5/16-18 x 1-1/4
12	1	BUG-2668	Cable Anchor Bracket
13	1	BUG-1338	Name Plate
14	2	MET-1350-SS	M4 Hex Nut
15	2	MET-0959-SS	Flt Hd Soc Scr M4 x 20
16	1	WAS-0250	5/16 SAE Washer
*	1	KBUG-2273-15	Weld Contact Cable, 15 ft (4.6 m)
*	1	KBUG-2274-15**	Power Cable, 120V, 15 ft (4.6 m)
*	1	KBUG-5007	Motor Cable Assembly
*	1	KBUG-3092**	Remote Charger Cable, 120 V / 50-60 Hz / 1 Ph
*	4	MET-0552-SS	Soc Hd Cap Scr M4 x 8
*	4	WAS-5551-SS	5/16 SAE Washer

\* Not Shown

20 \*\* Note: For K-BUG 5102 (240V model), Power Cable is KBUG-2272-15 and Remote Charger is KBUG-3093.

# K-BUG 5000 & K-BUG 5100 WIRING DIAGRAM

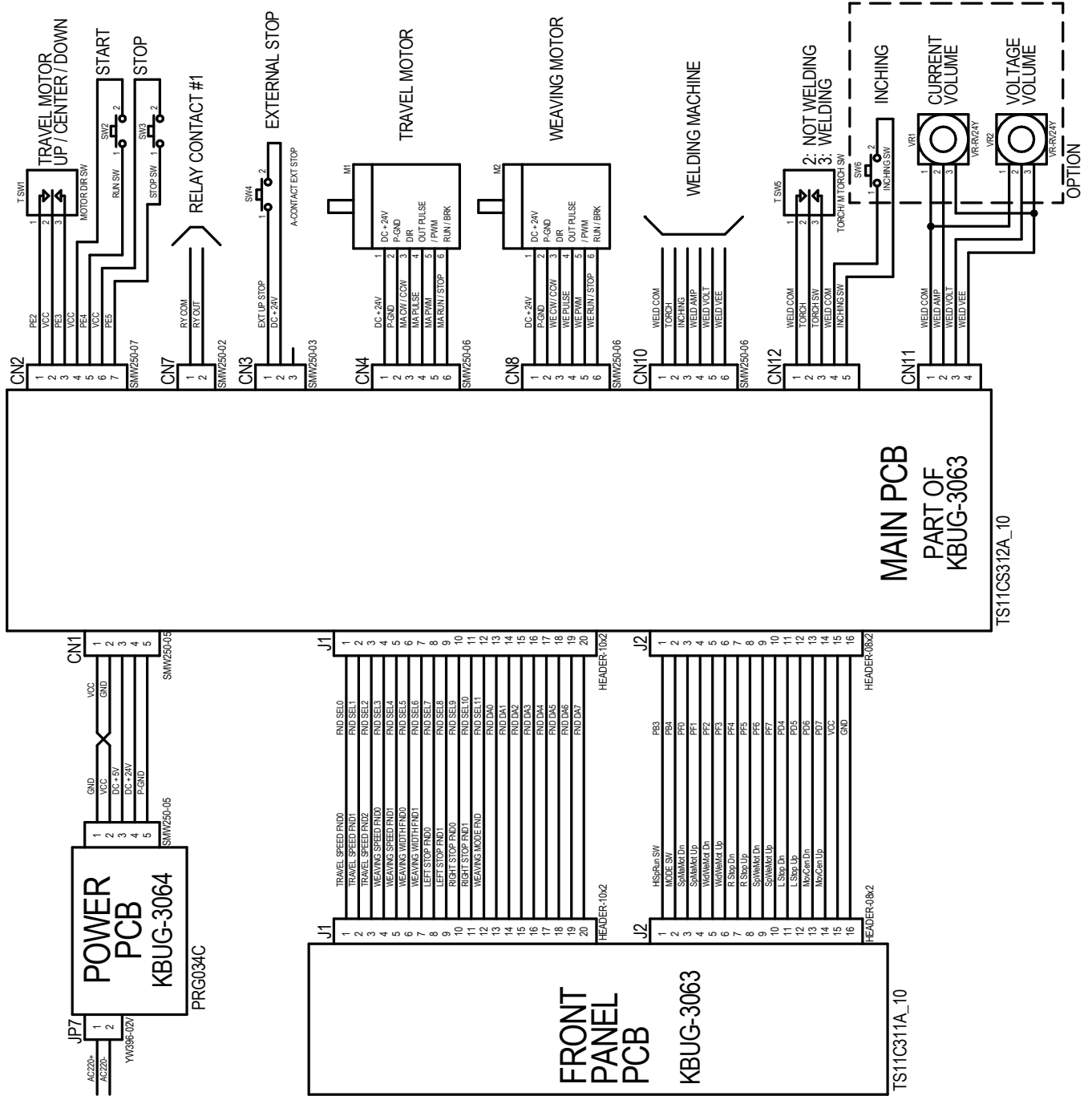

# SBG-450- - GUN & CABLE ASSEMBLY / EXPLODED VIEW / PARTS LIST

Whip Length: 15 (15 ft / 4.6 m) or 25 (25 ft / 7.6 m)  
 Wire Size: 035, 040, 045, 052, 116, 564  
 Connector Type: E (Euro), L (Lincoln 3/4"), M (Miller), T (Lincoln, small)

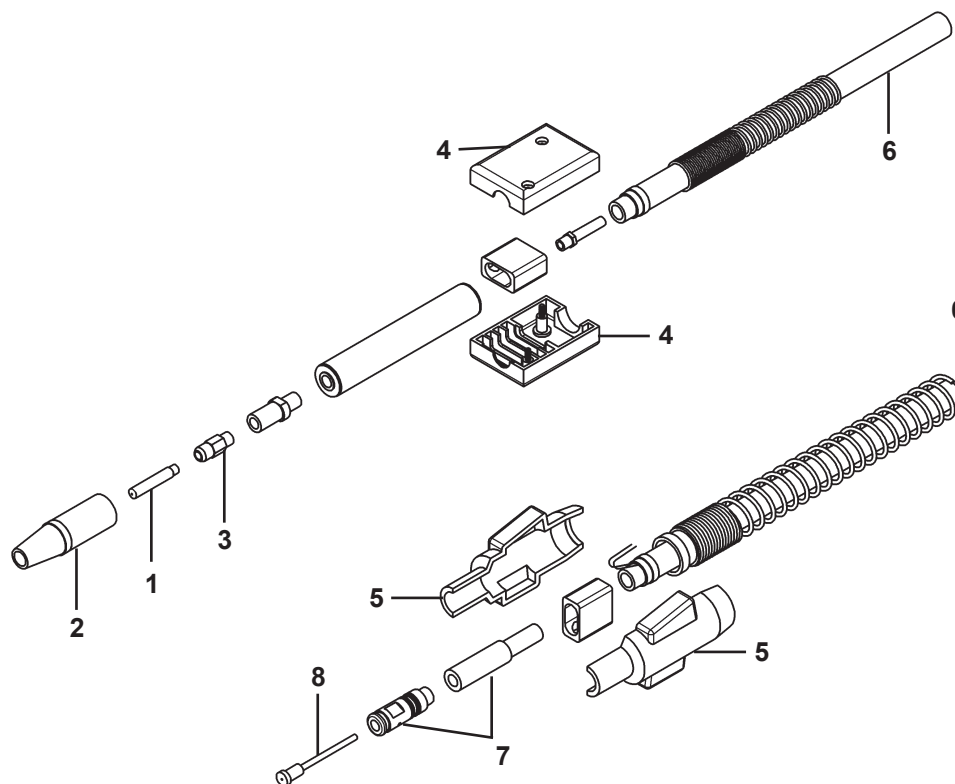

PARTS LIST				WIRE SIZE					
ITEM	QTY	PART NO.	DESCRIPTION	.035 (.9 mm)	.040 (1.0)	.045 (1.2)	.052 (1.4)	1/16 (1.6)	5/64 (2.0)
1	1	BUG-3159-35	16S-35 (.9 mm) Contact Tip	X					
1	1	BUG-3159-45	16S-45 (1.2 mm) Contact Tip			X			
1	1	BUG-3159-52	16S-52 (1.4 mm) Contact Tip				X		
1	1	BUG-3159-116	16S-116 (1.6 mm) Contact Tip					X	
1	1	BUG-3159-564	16S-564 (2.0 mm) Contact Tip						X
1	1	PWS-4436-1.0	16S-40 (1.0 mm) Contact Tip		X				
2	1	PWS-4447	27S62 H.D. Nozzle 5/8"	X	X	X	X	X	X
3	1	PWS-4449	PX57HD Gas Diffuser	X	X	X	X	X	X
4	1	CWO-8017	Case w/ Binder Screws (Front)	X	X	X	X	X	X
5	1	PWS-4411	Case w/ Binder Screws (Back)	X	X	X	X	X	X
6	1	STW-3044	450 Amp Cable	X	X	X	X	X	X
7	1	R174-T	Connector, Small Lincoln						
7	1	R174-L	Connector, 3/4" Lincoln						
7	1	R174-M	Connector, Miller						
7	1	R174-X	Connector, Euro						
8	1	CWO-8009	44-3545-15 Cable Liner	X	X	X			
8	1	CWO-8011	44-116-15 Cable Liner				X	X	
8	1	CWO-8012	44-564-15 Cable Liner						X
**	1	SBG-1004	Gas Hose Assembly	X	X	X	X	X	X
**	2	SBG-1005	Gas Hose Clamps	X	X	X	X	X	X

# WARRANTY

## LIMITED WARRANTY

MODEL \_\_\_\_\_  
SERIAL NO. \_\_\_\_\_  
DATE PURCHASED: \_\_\_\_\_

FOR A PERIOD OF TWELVE (12) MONTHS FROM DELIVERY, BUG-O SYSTEMS WARRANTS TO THE ORIGINAL PURCHASER (DOES NOT INCLUDE AUTHORIZED DISTRIBUTORS), THAT A NEW MACHINE IS FREE FROM DEFECTS IN MATERIAL AND WORKMANSHIP AND AGREES TO REPAIR OR REPLACE, AT ITS OPTION, ANY DEFECTIVE PARTS OR MACHINE. THIS WARRANTY DOES NOT APPLY TO MACHINES, WHICH AFTER OUR INSPECTION, ARE DETERMINED TO HAVE BEEN DAMAGED DUE TO NEGLIGENCE, ABUSE, OVERLOADING, ACCIDENT OR IMPROPER USAGE. ALL SHIPPING AND HANDLING CHARGES WILL BE PAID BY CUSTOMER.

BUG-O SYSTEMS MAKES NO WARRANTY OF MERCHANTABILITY AND MAKES NO OTHER WARRANTY, EXPRESSED OR IMPLIED, BEYOND THE WARRANTY EXPRESSLY SET FORTH ABOVE. BUYER'S REMEDY FOR BREACH OF WARRANTY, HEREUNDER, SHALL BE LIMITED TO REPAIR OR REPLACEMENT OF NON-CONFORMING PARTS AND MACHINES. UNDER NO CIRCUMSTANCES SHALL CONSEQUENTIAL DAMAGES BE RECOVERABLE.

**HOW TO OBTAIN SERVICE:**

**IF YOU THINK THIS MACHINE IS NOT OPERATING PROPERLY, RE-READ THE INSTRUCTION MANUAL CAREFULLY, THEN CALL YOUR AUTHORIZED BUG-O DEALER/DISTRIBUTOR. IF HE CANNOT GIVE YOU THE NECESSARY SERVICE, WRITE OR PHONE US TO TELL US EXACTLY WHAT DIFFICULTY YOU HAVE EXPERIENCED. BE SURE TO MENTION THE MODEL AND SERIAL NUMBERS.**