

INSTRUCTIONS AND PARTS MANUAL

FTS w/ AUTOMATIC HEIGHT CONTROL

FTS-1025

Please record your equipment identification information below for future reference. This information can be found on your machine nameplate.

Model Number _____

Serial Number _____

Date of Purchase _____

Whenever you request replacement parts or information on this equipment, always supply the information you have recorded above.

LIT-FTS-AHC-IPM-0321

Bug-O Systems is committed to empowering our customers by providing operator controlled mechanized solutions for their welding, cutting and custom applications.



BUG-O SYSTEMS

A DIVISION OF WELD TOOLING CORPORATION



280 TECHNOLOGY DRIVE CANONSBURG, PENNSYLVANIA 15317-9564 USA
PHONE: 1-412-331-1776 <http://www.bugo.com> FAX: 1-412-331-0383

SAFETY

PROTECT YOURSELF AND OTHERS FROM SERIOUS INJURY OR DEATH. KEEP CHILDREN AWAY. BE SURE THAT ALL INSTALLATION, OPERATION, MAINTENANCE AND REPAIR PROCEDURES ARE PERFORMED ONLY BY QUALIFIED INDIVIDUALS.



ELECTRIC SHOCK can kill.

- 1) The equipment is not waterproof. Using the unit in a wet environment may result in serious injury. Do not touch equipment when wet or standing in a wet location.
- 2) The unused connectors have power on them. Always keep the unused connectors covered with the supplied protective panels. Operation of the machine without the protective panels may result in injury.
- 3) Never open the equipment without first unplugging the power cord or serious injury may result.
- 4) Verify the customer-supplied power connections are made in accordance with all applicable local and national electrical safety codes. If none exist, use International Electric Code (IEC) 950.
- 5) Never remove or bypass the equipment power cord ground. Verify the equipment is grounded in accordance with all applicable local and national electrical safety codes. If none exist, use International Electric Code (IEC) 950.

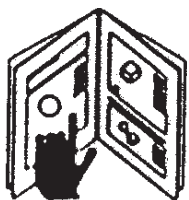

READ INSTRUCTIONS.

Read the instruction manual before installing and using the equipment.



EQUIPMENT DAMAGE POSSIBLE.

- 1) Do not plug in the power cord without first verifying the equipment is OFF and the cord input voltage is the same as required by the machine or serious damage may result.
- 2) Always verify both the pinion and wheels are fully engaged before applying power or equipment damage may occur.
- 3) Do not leave the equipment unattended.
- 4) Remove from the worksite and store in a safe location when not in use.



FALLING EQUIPMENT can cause serious personal injury and equipment damage.

Faulty or careless user installation is possible. As a result, never stand or walk underneath equipment.



MOVING PARTS can cause serious injury.

- 1) Never try to stop the pinion from moving except by removing power or by using the STOP control.
- 2) Do not remove any protective panels, covers or guards and operate equipment.

HIGH FREQUENCY WARNINGS

SPECIAL PRECAUTIONS ARE REQUIRED WHEN USING PLASMA, TIG OR ANY WELDING PROCESS THAT USES HIGH FREQUENCY TO STRIKE AN ARC.



WARNING: HIGH FREQUENCY CAN EFFECT MACHINE OPERATION AND THEREFORE, WELD QUALITY.

Read the precautions below before installing and using the equipment.

PRECAUTIONS:

- 1) Some plasma or welding cables are strong sources of high frequency interference. NEVER lay a plasma or welding cable across the controls of the machine.
- 2) Always physically separate the plasma or welding cable leads from the machine cables. For example, the plasma or welding cable leads should NEVER be bundled with a pendant cable or the machine power cord. Maximize the separation between any machine cables and the plasma or welding cables.
- 3) Strictly follow the grounding procedures specified for the plasma or welding unit. NOTE: Some plasma and welding units produce exceptionally large amounts of high frequency noise. They may require a grounding rod be driven into the earth within six feet (2 meters) of the plasma or welding unit to become compatible with an automatic cutting or welding process.
- 4) If the high frequency is produced using a spark gap, adjust the points so the gap is as small as possible. The larger the gap, the higher the voltage and the higher the interference.
- 5) Some plasma or welding units will inject high frequency interference into the AC power line. Use separate power line branches whenever possible to power the plasma or welding source and the machine. Do not plug them into the same outlet box.
- 6) High frequency noise may enter the machine through the plasma or welding supply remote contactor leads. Some plasma and welding sources can produce noise spikes of up to several thousand volts. These sources are not compatible with automated cutting and welding equipment. It is recommended that the remote contactor leads on these plasma or welding sources not be connected to the machine. An alternate solution is to purchase a separate remote contactor isolation box.

FTS w/ AUTOMATIC HEIGHT CONTROL

FTS-1025

INSTRUCTIONS AND PARTS MANUAL

TABLE OF CONTENTS

- SAFETY 2
- INTRODUCTION..... 5
- FEATURES..... 5
- TECHNICAL DATA 5
- CONNECTING THE SHUNT 6
- AUTOMATED HEIGHT CONTROL 6
- WHEEL ADJUSTMENT 6
- RACKER MAINTENANCE 6
- AHC CONTROL UNIT 7
- FTS-1025 FTS with AUTOMATED HEIGHT CONTROL / PARTS LIST / EXPLODED VIEW..... 8
- FTS-1030-NC F/S TORCH SUPPORT w/ MOTOR. HEIGHT / PARTS LIST / EXPLODED VIEW..... 9
- FTS-1015 DUAL RACKER WITH VERTICAL MOTOR / PARTS LIST / EXPLODED VIEW..... 10
- CAS-1210-FTS AMP SENSING CONTROL UNIT / PARTS LIST / EXPLODED VIEW..... 11
- CAS-1210-FTS AMP SENSING CONTROL UNIT / WIRING DIAGRAM 12
- AMP SENSING CONTROL UNIT / ELECTRICAL COMPONENT CHART ... 12
- CAS-1025 SHUNT & FILTER ASS'Y / PARTS LIST / EXPLODED VIEW 13
- CAS-1025 SHUNT & FILTER ASS'Y / WIRING DIAGRAM..... 13
- CWO-1697 MOTOR ASS'Y / PARTS LIST / EXPLODED VIEW 14
- ACCESSORIES 15
- WARRANTY 17
- HOW TO OBTAIN SERVICE:..... 17

Patents Pending

INTRODUCTION

The FTS-1025 Freestanding Torch Support with Automated Height Control (AHC) is a compact easy to use system designed to maintain a constant torch-to-work distance automatically. A shunt continuously monitors the welding current, and the controller adjusts the torch height to maintain constant torch-to-work distance. Rack and pinion movement on hardened V-ways provides smooth and effortless positioning of the welding gun or cutting torch. Can be used with Sub-Arc, Innershield and MIG welding.

FEATURES

Multi-turn potentiometer with dial display for current set-point.

Automatic AHC shutoff for low current.

Built-in time delay after arc is struck, before AHC begins current sensing.

Manual jog to override AHC while welding.

Speed control potentiometer sets speed during manual operation, limits top speed for AHC.

Four quadrant motor for smooth vertical travel.

TECHNICAL DATA

| | |
|------------------------------|--|
| Total Vertical Adjustment: | 25" (635 mm) |
| Total Horizontal Adjustment: | 25" (635 mm) |
| Net Weight: | 49 lb (22 kg) |
| Power Supply: | 120 VAC / 50-60 Hz / 1 Phase 240 VAC / 50-60 Hz / 1 Phase |
| Capacity: | 20 lb (9 kg) |

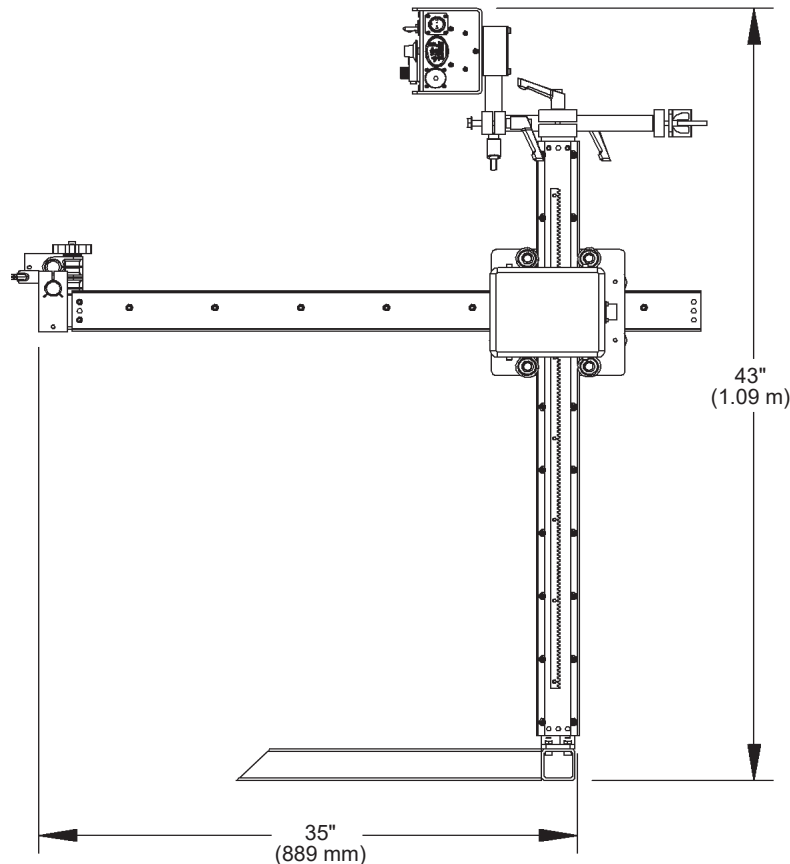

FTS-1025 requires a Constant Voltage (**CV**) Power Source.
Consult the factory for your particular application.

POWER SOURCE

Use only constant voltage type power sources with this welding device. If using a multiple process power source, be sure that it is set for constant voltage output as per the instructions in the power source manual. Set the power source polarity switch properly or connect the electrodes and work leads for the correct electrode polarity.

CONNECTING THE SHUNT

Connect the shunt “in-line” on the welding power source ground cable. The shunt’s positive lead and the signal output cable are located on the same side of the enclosure. For a positive electrode, this lead should be connected to the work piece.

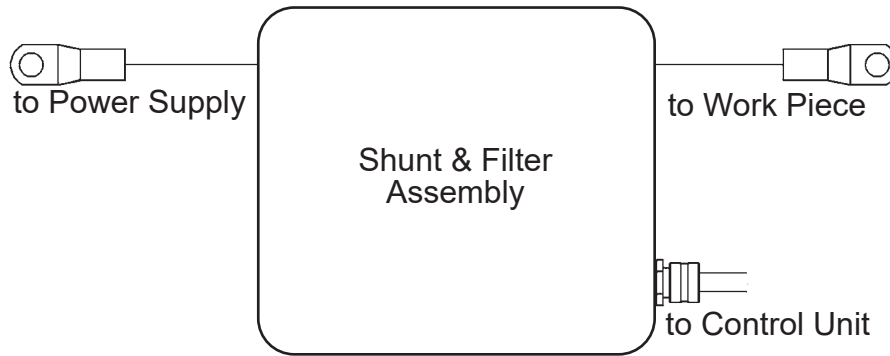

AUTOMATED HEIGHT CONTROL

The FTS-1025 features automated height control (AHC), which controls the welding tip to work distance and maintains a constant weld current that results in more uniform weld penetration. AHC continually senses and filters the actual weld current, then compares this value to the set-point, and raises or lowers the welding gun accordingly. AHC features a built-in time delay after the arc is struck, and automatically shuts off when current drops too low (below 55 amp). The operator can temporarily override AHC using the manual jog switch while welding. AHC resumes as soon as the jog switch is released.

NOTE: AHC is designed to work with the welding gun *above* the work piece. Contact BUG-O Systems for other configurations.

WHEEL ADJUSTMENT

The ABR Dual Racker (FTS-1015) is equipped with wheels that ride along the V-ways. For each racker direction, one set of wheels is fixed and one set is adjustable. Check the racker unit for proper wheel adjustment before use. The wheels need adjustment if you can cock or wiggle components out of alignment. The wheels should be snug, but not prohibit movement along the path of travel.

The wheels with the hex stand off are adjustable (Pg 10, Item 13). To adjust the wheels, loosen the hex bolt (A) until the adjustable bushing (B) can be rotated. Correct the wheel alignment by rotating adjustable bushing (B). Once adjusted, hold the adjustable bushing (B) while tightening the hex bolt (A). Recheck alignment.

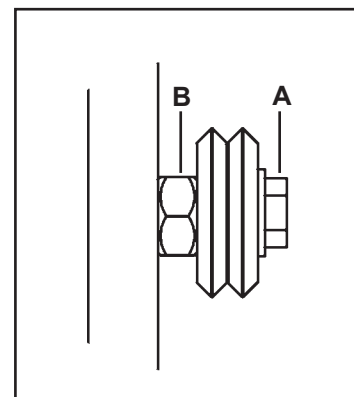

Adjustable Wheel

RACKER MAINTENANCE

BUG-O Systems recommends inspecting the racker system daily. Inspect the gear rack, V-ways and wheels. Remove all dirt, grease and rust. Inspect V-ways for nicks and replace as needed. Check wheel alignment and adjust as needed to maintain snug fit and smooth operation. Lubricate V-ways with dry spray lubricant. Lubricate pinion with dry Teflon or graphite spray.

AHC CONTROL UNIT

All vertical racking for the FTS-1025 is motorized and controlled with the AHC Control Unit (shown below).

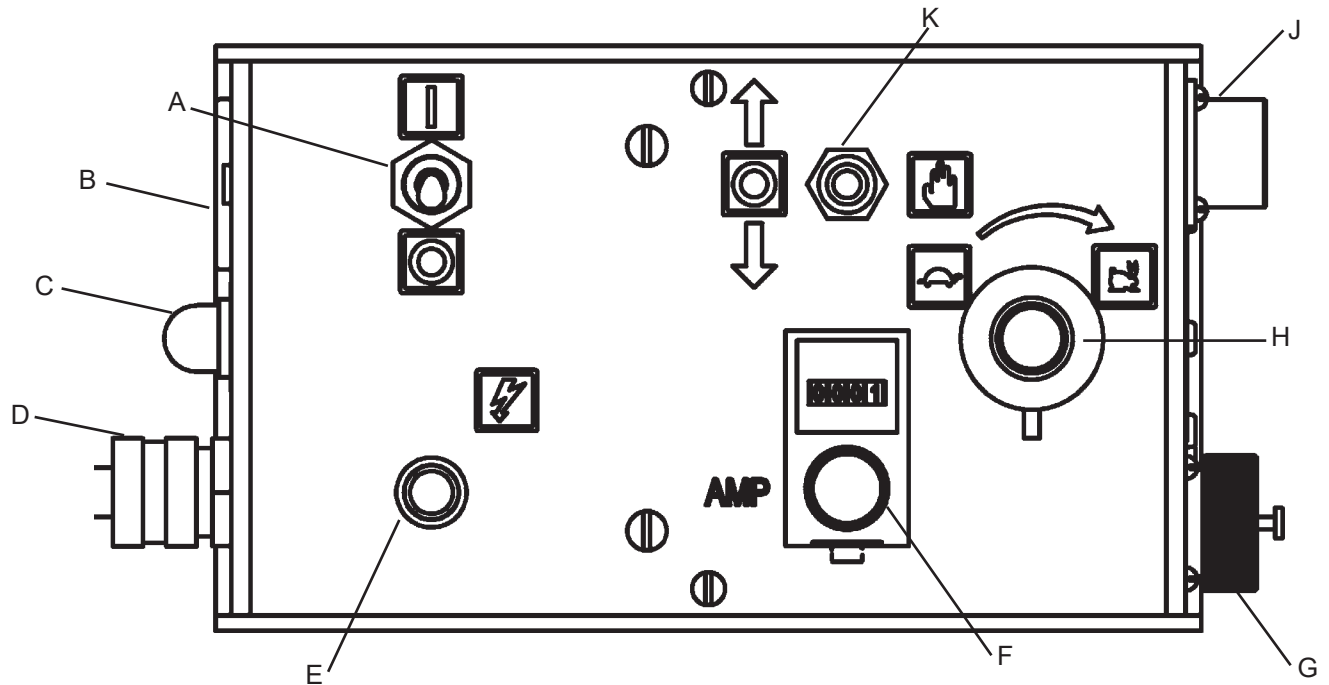

Features and Functions of the AHC Control Unit:

- A. Main Power Switch - Turn control power on or off.
- B. Auxiliary Power Receptacle
- C. Circuit Breaker Reset - Resets control circuit after overload.
- D. Power Cord - Input power to the Control Unit
- E. Pilot Light - Lit when Control Unit is plugged in and turned on.
- F. Current Set Point Control and Display - Displays AHC current setpoint (in amps); range 0 - 500 amps. Turn knob clockwise to increase set point, counterclockwise to decrease.
- G. Motor Connection (Cap & Chain) - Plug cable from motorized racker here.
- H. Speed Control - Regulates the speed of vertical travel. Turn knob clockwise to increase speed, counterclockwise to decrease.
- J. Shunt & Filter Receptacle - Connect cable from Shunt and Filter Assembly here.
- K. Manual Jog Switch - Used to raise and lower vertical racker when not welding. Overrides AHC when welding.

FTS-1025 FREESTANDING TORCH SUPPORT with AUTOMATED HEIGHT CONTROL / PARTS LIST / EXPLODED VIEW

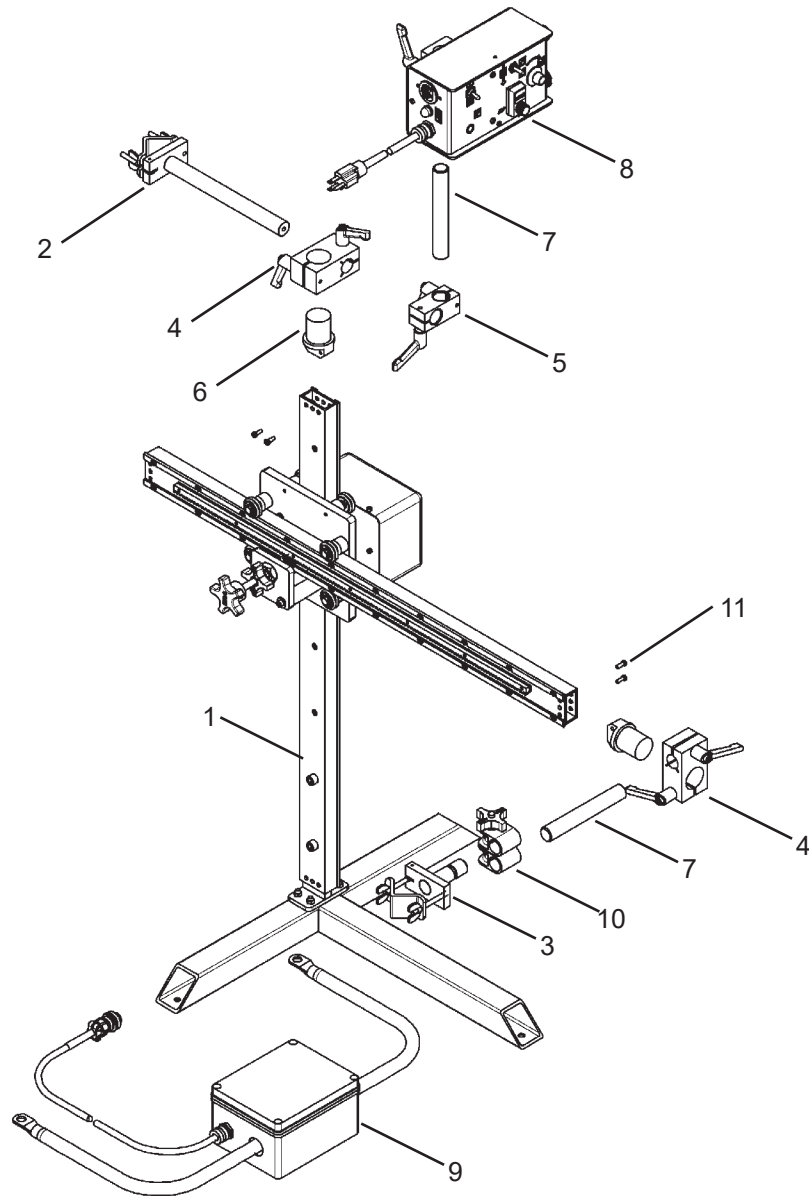

| ITEM | QTY | PART No. | DESCRIPTION |
|------|-----|--------------|--|
| 1 | 1 | FTS-1030-NC | F/S Torch Support with Motor. Height Ass'y |
| 2 | 1 | BUG-2668 | Cable Anchor Bracket |
| 3 | 1 | BUG-2708 | Clamp |
| 4 | 2 | BUG-5182 | Right Angle Clamp |
| 5 | 1 | BUG-5462 | Right Angle Clamp |
| 6 | 2 | BUG-5548 | Swivel Rod Adaptor |
| 7 | 1 | BUG-9180-6 | Rod, 6" |
| 8 | 1 | CAS-1210-FTS | Control Unit, Amp Sensing, 120V |
| | 1 | CAS-1212-FTS | Control Unit, Amp Sensing, 240V |
| 9 | 1 | CAS-1025 | Filter & Shunt Ass'y |
| 10 | 1 | CON-1020 | Swivel Clamp Ass'y |
| 11 | 4 | FAS-0555 | Screw, Soc Hd Cap 1/4-20 x 1/2 |
| 12 | 1 | FTS-1026 | Cable Ass'y, 36" 2-T (Not Shown) |

FTS-1030-NC F/S TORCH SUPPORT w/ MOTOR. HEIGHT / PARTS LIST / EXPLODED VIEW

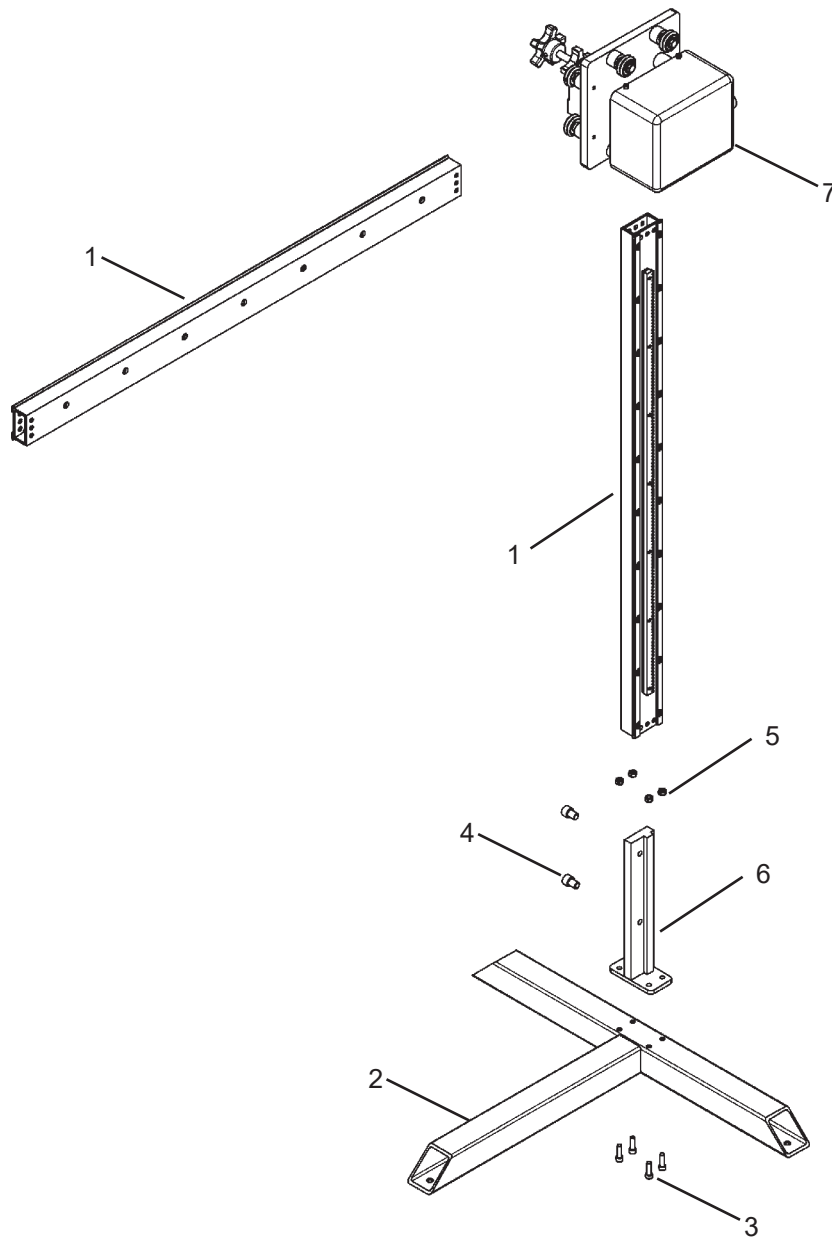

| ITEM | QTY | PART No. | DESCRIPTION |
|------|-----|----------|--------------------------------|
| 1 | 2 | ABR-1060 | V-Guide Ways 33" |
| 2 | 1 | BUG-3605 | Torch Support Base |
| 3 | 4 | FAS-0557 | Screw, Soc Hd Cap 1/4-20 x 3/4 |
| 4 | 2 | FAS-0595 | Screw, Soc Hd Cap 3/8-16 x 1/2 |
| 5 | 4 | FAS-1351 | Hex Nut 1/4-20 |
| 6 | 1 | FTS-1005 | ABR Support Post |
| 7 | 1 | FTS-1015 | Dual Racker w/ Motorized |

FTS-1015 DUAL RACKER WITH VERTICAL MOTOR / PARTS LIST / EXPLODED VIEW

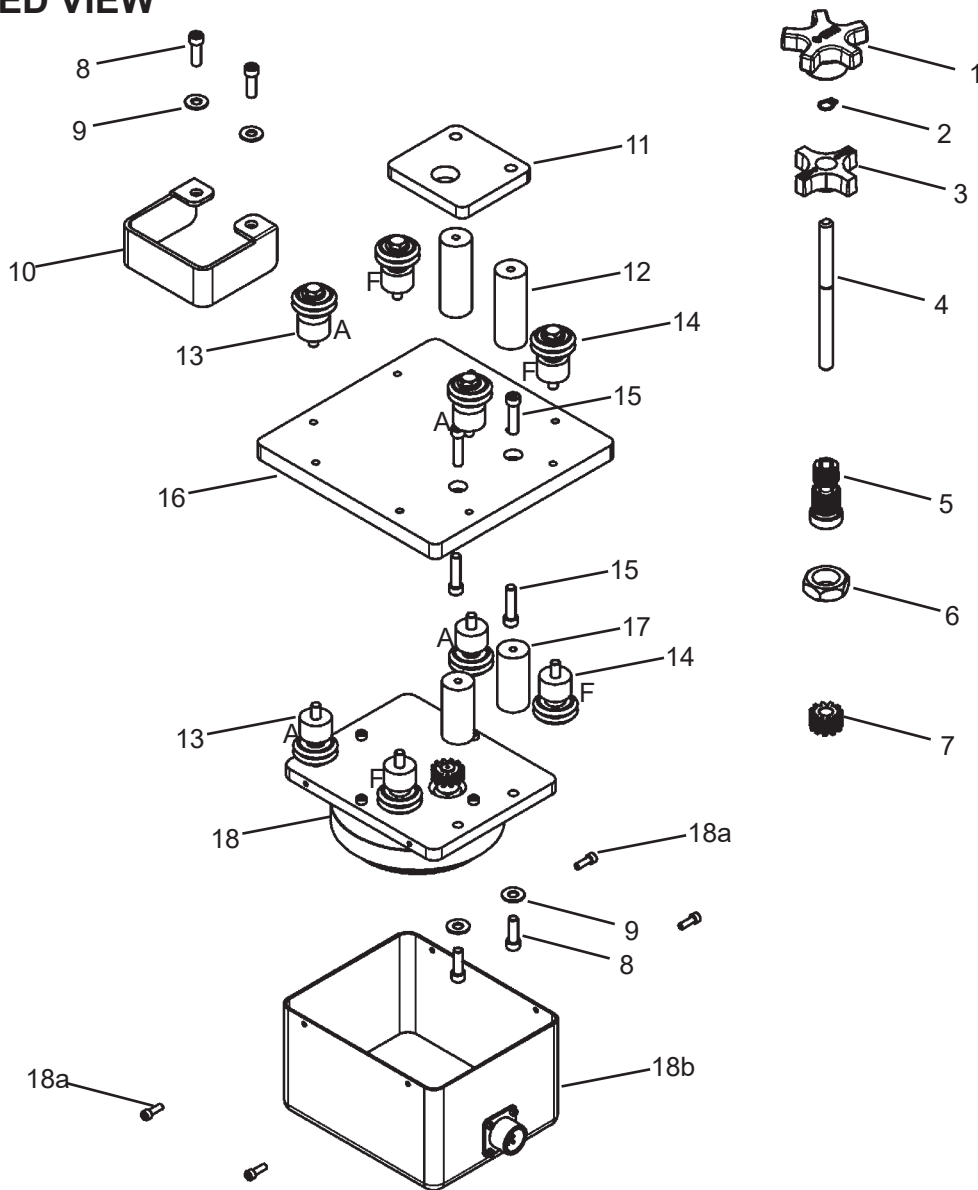

| ITEM | QTY | PART No. | DESCRIPTION |
|------|-----|----------|---|
| 1 | 1 | BUG-2032 | Knob, Black |
| 2 | 1 | MUG-1579 | Retaining Ring, 3/8" |
| 3 | 1 | MUG-1142 | Knob, Locking |
| 4 | 1 | MUG-1144 | Shaft |
| 5 | 1 | MUG-1141 | Bearing, Collet |
| 6 | 1 | FAS-1307 | Hex Jam Nut, 3/4-16 |
| 7 | 1 | CWO-1679 | Pinion Gear |
| 8 | 4 | FAS-0557 | Screw, Soc Hd Cap 1/4-20 x 3/4 |
| 9 | 4 | WAS-0240 | Washer, SAE Flat 1/4" |
| 10 | 1 | CWO-1671 | Racker Shield |
| 11 | 1 | CWO-1678 | Racker Plate |
| 12 | 2 | MUG-1453 | Stand-Off, Manual Side |
| 13 | 4 | CWO-1681 | W2 Adj. Leg & Wheel |
| 14 | 4 | CWO-1680 | W2 Fixed Leg & Wheel |
| 15 | 4 | FAS-0559 | Screw, Soc Hd Cap 1/4-20 x 1" |
| 16 | 1 | FTS-1011 | Dual Racker Plate |
| 17 | 2 | CWO-1694 | Stand-Off, Motor Side |
| 18 | 1 | CWO-1697 | 150:1 Motor Assembly (Includes 18a & 18b) |
| 18a | 4 | FAS-0525 | Screw, Soc Hd Cap 8-32 x 1/2 |
| 18b | 1 | CWO-1696 | Motor Enclosure |

CAS-1210-FTS AMP SENSING CONTROL UNIT / PARTS LIST / EXPLODED VIEW

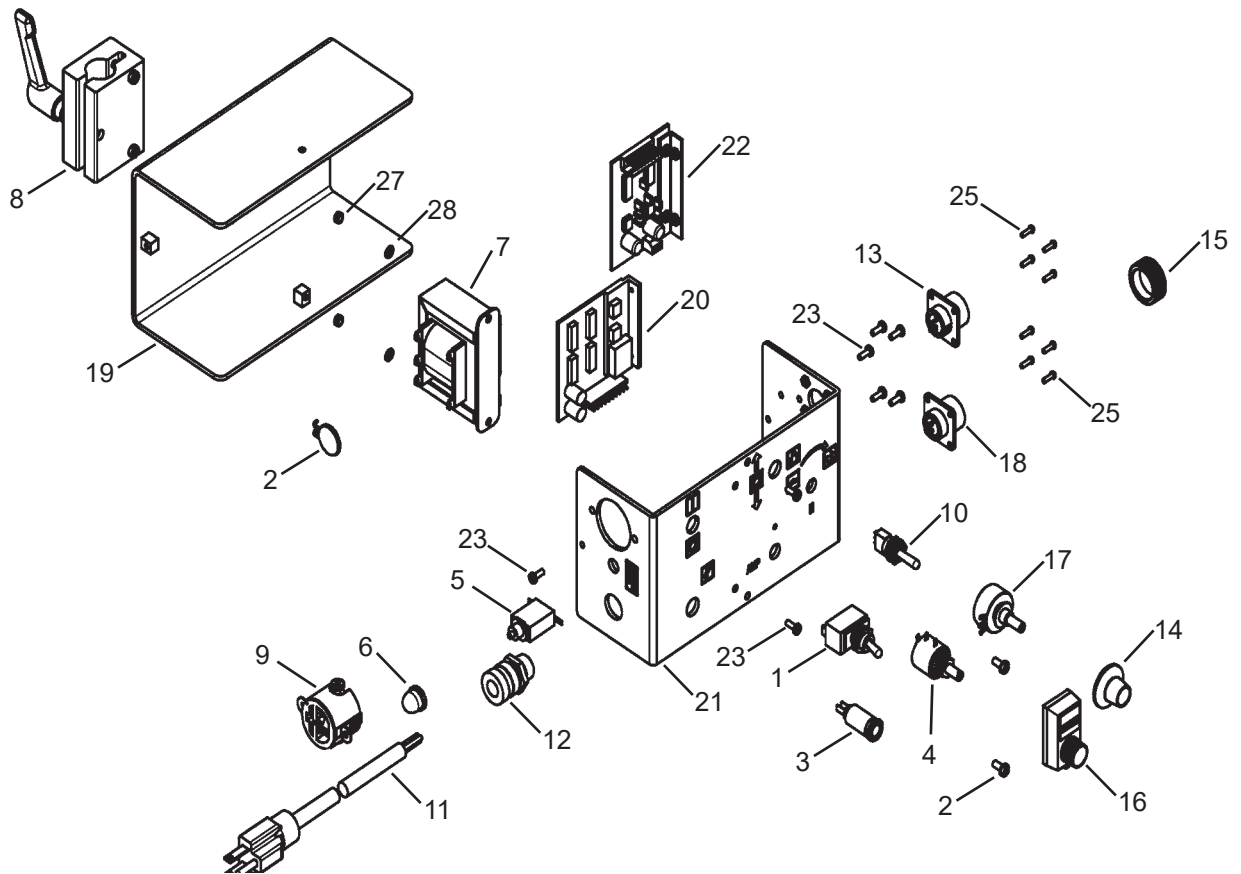

| ITEM | QTY | PART No. | DESCRIPTION |
|------|-----|--------------|-------------------------------|
| 1 | 1 | ABP-1069 | Toggle Switch |
| 2 | 1 | BUG-1393 | Volt Trap 120 VAC |
| 3 | 1 | BUG-1415 | Pilot Light |
| 4 | 1 | BUG-1572 | Potentiometer, 10k |
| 5 | 1 | BUG-2923 | 0.7 Amp Circuit Breaker |
| 6 | 1 | BUG-2942 | Reset Seal, Transparent |
| 7 | 1 | BUG-5001 | Transformer 120 VAC |
| 8 | 1 | BUG-5295 | Rod Mount Ass'y |
| 9 | 1 | BUG-5321 | Single Power Receptacle |
| 10 | 1 | BUG-5323 | Toggle Switch, On-Off-On |
| 11 | 1 | BUG-9445 | Power Cord |
| 12 | 1 | BUG-9446 | Cord Grip |
| 13 | 1 | BUG-9486 | Panel Connector, 2T, Male |
| 14 | 1 | BUG-9621 | Knob |
| 15 | 1 | BUG-9628 | Cap & Chain Ass'y |
| 16 | 1 | BUG-9676 | Dial Counter |
| 17 | 1 | POT WTE 2001 | Potentiometer, 5k ohm |
| 18 | 1 | BUG-9856 | Panel Connector, 2T, Female |
| 19 | 1 | CAS-1019 | Rear Cover |
| 20 | 1 | CAS-1050 | Arc Sensing Control |
| 21 | 1 | CAS-1218 | Front Cover |
| 22 | 1 | CAS-1770 | Speed Control (Iron Rotor) |
| 23 | 8 | FAS-0114 | Screw, Pan Hd 6-32 x 3/8 |
| 24 | 2 | FAS-0124 | Screw, Pan Hd 8-32 x 3/8 |
| 25 | 8 | FAS-0204 | Screw, Rnd Hd Slit 4-40 x 3/8 |
| 26 | 8 | FAS-1305 | Hex Nut 4-40 |
| 27 | 2 | FAS-1320 | Hex Nut 8-32 |
| 28 | 2 | WAS-0221 | #8 Internal Star Lockwasher |

CAS-1210-FTS AMP SENSING CONTROL UNIT / WIRING DIAGRAM

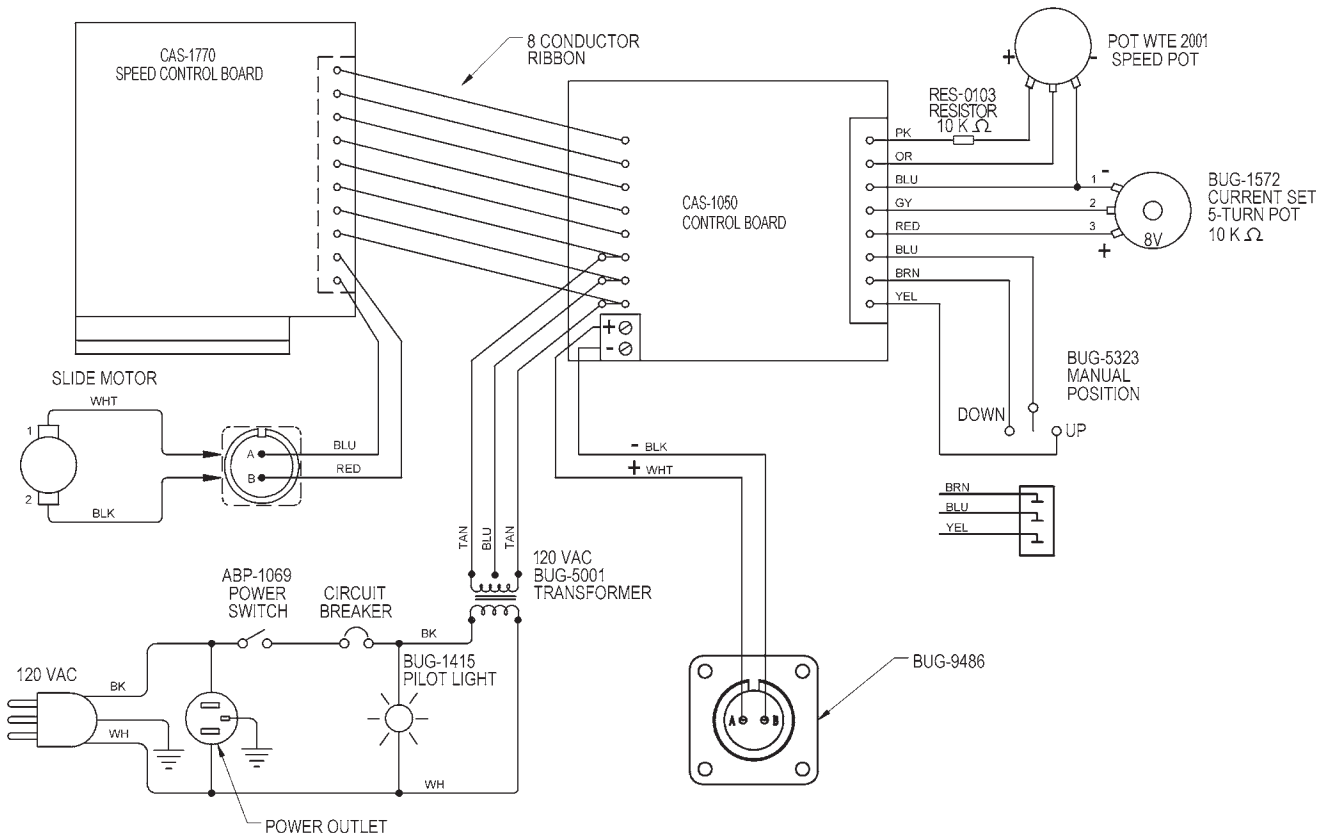

AMP SENSING CONTROL UNIT / ELECTRICAL COMPONENT CHART

| DESCRIPTION | PART NO. | |
|----------------------------|-----------------------|---------------------------|
| | FTS-1025 (120 VAC) | FTS-1025-240 (240 VAC) |
| Control Unit | CAS-1210-FTS | CAS-1212-FTS |
| Power Cord | BUG-9445 | GOF-3115 |
| Auxiliary Power Receptacle | BUG-5321 | BUG-9595 |
| Transformer | BUG-5001 | BUG-5002 |
| Circuit Breaker | BUG-2923 (0.7 AMP) | BUG-2925 (0.5 AMP) |
| Volt Trap | BUG-1393 | BUG-1563 |
| Pilot Light | BUG-1415 | BUG-1428 |

CAS-1025 SHUNT & FILTER ASS'Y / PARTS LIST / EXPLODED VIEW

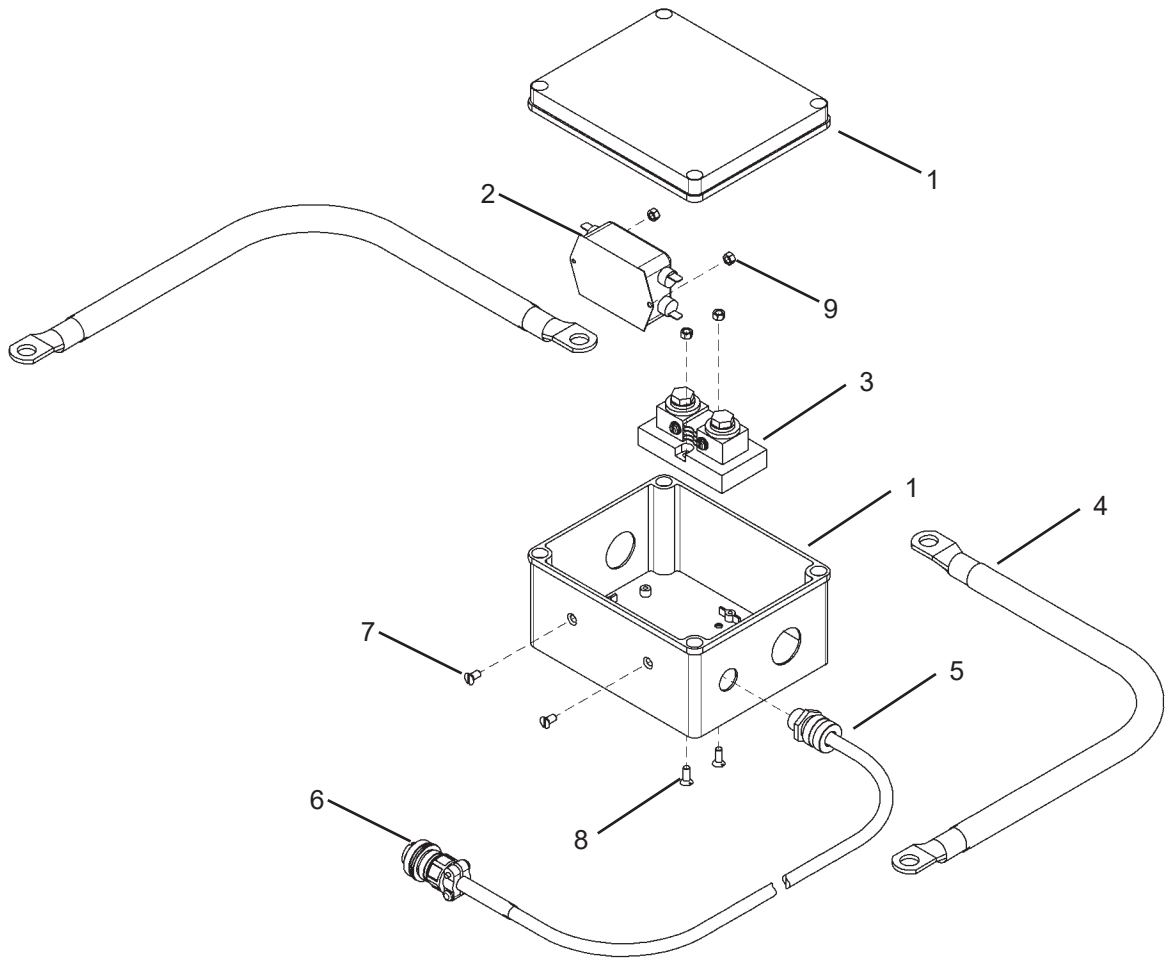

| ITEM | QTY | PART No. | DESCRIPTION |
|------|-----|----------|----------------------------|
| 1 | 1 | CAS-1026 | Enclosure |
| 2 | 1 | BUG-6069 | Filter |
| 3 | 1 | BUG-6071 | Shunt, 500 Amp, 50 mV |
| 4 | 4 | CWO-8061 | Welding Lug, 1/0 - 2/0 |
| 5 | 1 | BUG-9216 | Cord Grip |
| 6 | 1 | BUG-9487 | Cable Connector, 2-T |
| 7 | 2 | FAS-0834 | Screw, Flat Hd 10-24 x 3/8 |
| 8 | 2 | FAS-0835 | Screw, Flat Hd 10-24 x 1/2 |
| 9 | 4 | FAS-1330 | Hex Nut 10-24 |

CAS-1025 SHUNT & FILTER ASS'Y / WIRING DIAGRAM

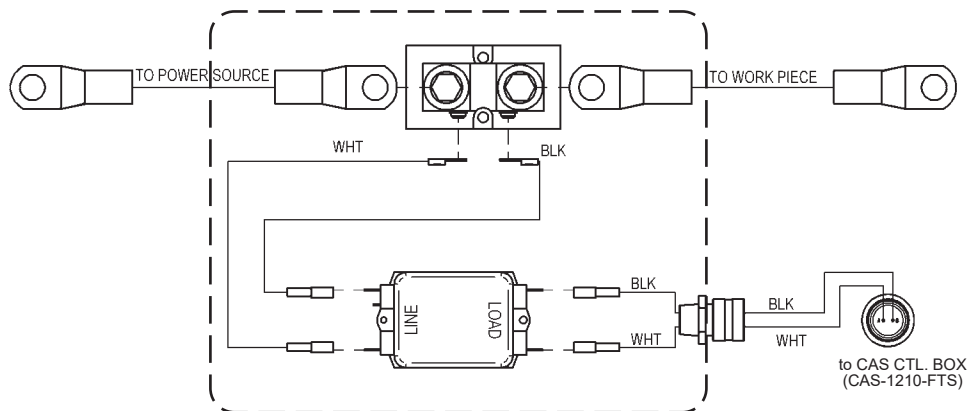

CWO-1697 MOTOR ASS'Y / PARTS LIST / EXPLODED VIEW

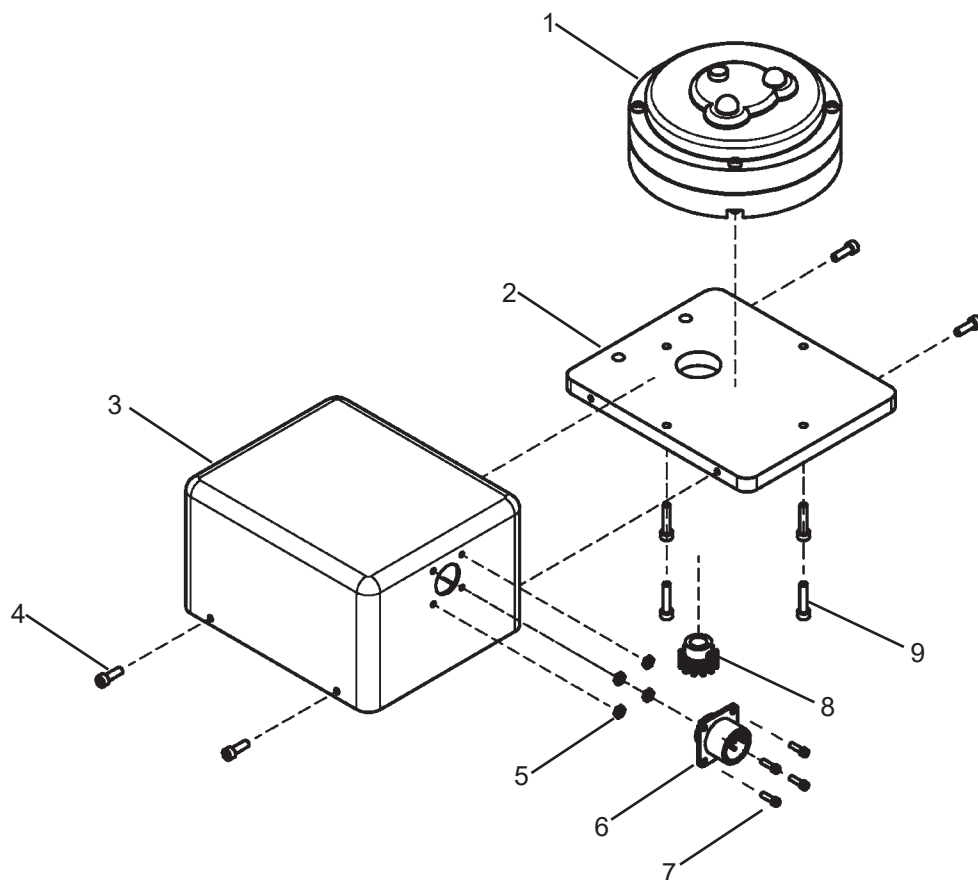

| ITEM | QTY | PART No. | DESCRIPTION |
|------|-----|----------|------------------------------|
| 1 | 1 | BUG-1550 | Gear Motor (150:1) |
| 2 | 1 | CWO-1693 | Racker Motor Plate |
| 3 | 1 | CWO-1696 | Motor Enclosure |
| 4 | 4 | FAS-0525 | Screw, Soc Hd Cap 8-32 x 1/2 |
| 5 | 4 | FAS-1305 | Hex Nut 4-40 |
| 6 | 1 | BUG-9486 | Panel Connector, 2T, Male |
| 7 | 4 | FAS-0504 | Screw, Soc Hd Cap 4-40 x 3/8 |
| 8 | 1 | GOF-3014 | Pinion, w/ Key Set Screw |
| 9 | 4 | FAS-0527 | Screw, Soc Hd Cap 8-32 x 3/4 |

ACCESSORIES

CDS-6350 LINEAR WEAVER

The CDS-6350 is a compact weaver unit capable of both linear weave and straight line welding. Intended for use with the Freestanding Torch Support.

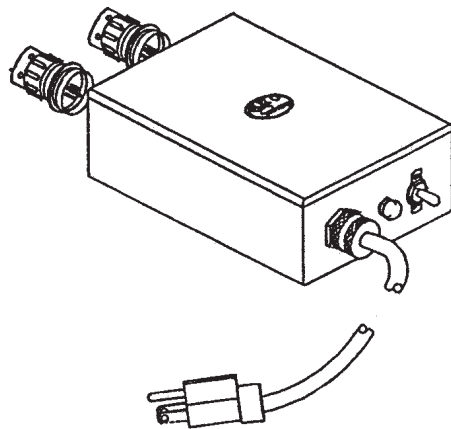
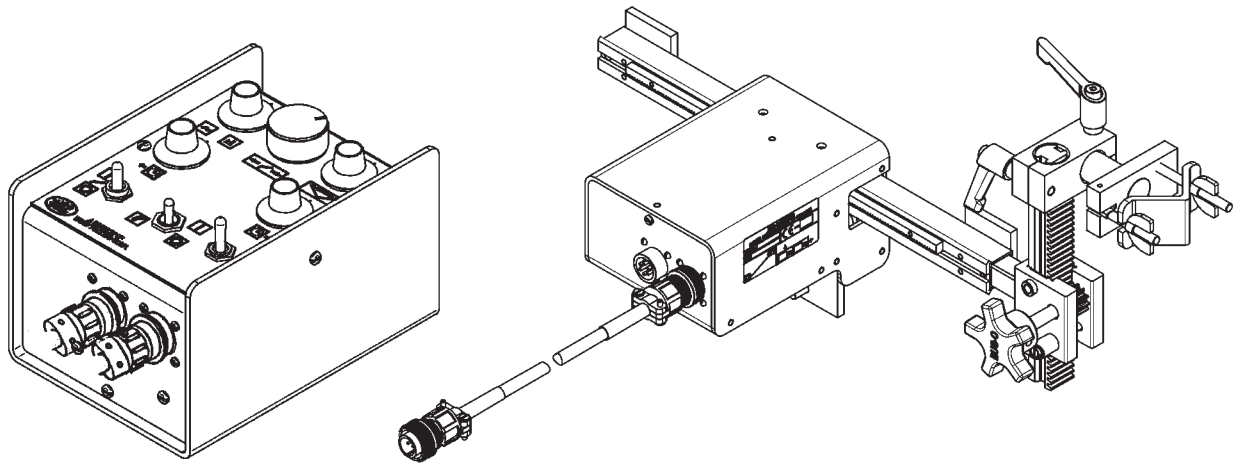

The FTS-1025 shown with Linear Weaver (CDS-6350) and Positioner (BPG-450-L).

ACCESSORIES

BUG-6350 PENDULUM WEAVER

The BUG-6350 pendulum weaver unit is designed for use with the Freestanding Torch Support. It offers both straight line welding and pendulum weave welding. Great for corners.

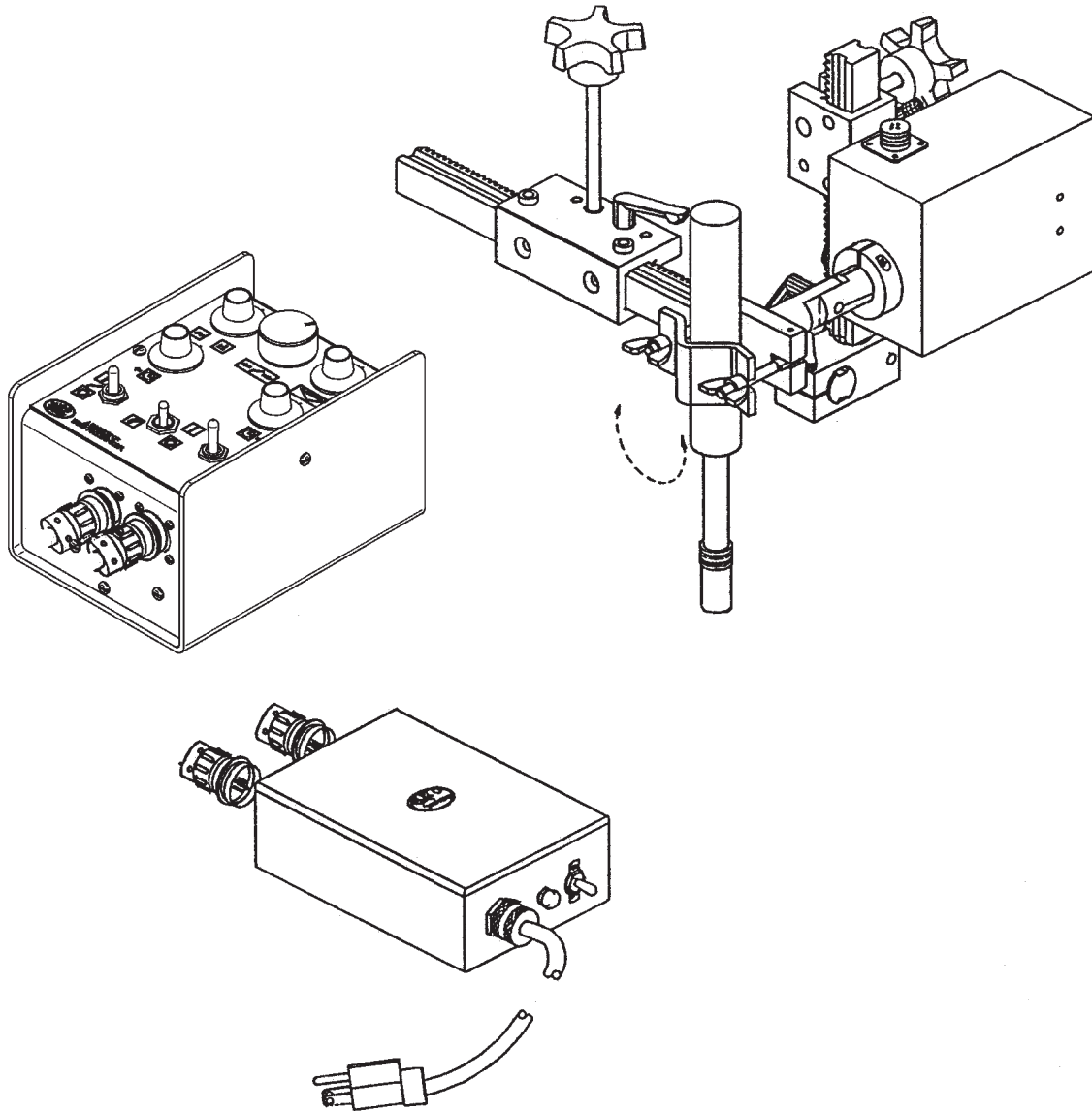

WARRANTY

Limited 3-Year Warranty

MODEL _____
SERIAL NO. _____
DATE PURCHASED: _____
WHERE PURCHASED: _____

For a period ending one (1) year from the date of invoice, Manufacturer warrants that any new machine or part is free from defects in materials and workmanship and Manufacturer agrees to repair or replace at its option, any defective part or machine. HOWEVER, if the invoiced customer registers the Product Warranty by returning the Warranty Registration Card supplied with the product within 90 days of the invoice date, or by registering on-line at www.bugo.com, Manufacturer will extend the warranty period an additional two (2) years which will provide three (3) total years from the date of original invoice to customer. This warranty does not apply to machines which, after Manufacturer's inspection are determined by Manufacturer to have been damaged due to neglect, abuse, overloading, accident or improper usage. All shipping and handling charges will be paid by the customer.

The foregoing express warranty is exclusive and Manufacturer makes no representation or warranty (either express or implied) other than as set forth expressly in the preceding sentence. Specifically, Manufacturer makes no express or implied warranty of merchantability or fitness for any particular purpose with respect to any goods. Manufacturer shall not be subject to any other obligations or liabilities whatsoever with respect to machines or parts furnished by Manufacturer.

Manufacturer shall not in any event be liable to Distributor or any customer for any loss of profits, incidental or consequential damages or special damages of any kind. Distributor's or customer's sole and exclusive remedy against Manufacturer for any breach of warranty, negligence, strict liability or any other claim relating to goods delivered pursuant hereto shall be for repair or replacement (at Manufacturer's option) of the machines or parts affected by such breach.

Distributor's Warranty:

In no event shall Manufacturer be liable to Distributor or to any customer thereof for any warranties, representations or promises, express or implied, extended by Distributor without the advance written consent of Manufacturer, including but not limited to any and all warranties of merchantability or fitness for a particular purpose and all warranties, representations or promises which exceed or are different from the express limited warranty set forth above. Distributor agrees to indemnify and hold Manufacturer harmless from any claim by a customer based upon any express or implied warranty by Distributor which exceeds or differs from Manufacturer's express limited warranty set forth above.

HOW TO OBTAIN SERVICE:

IF YOU THINK THIS MACHINE IS NOT OPERATING PROPERLY, RE-READ THE INSTRUCTION MANUAL CAREFULLY, THEN CALL YOUR AUTHORIZED BUG-O DEALER/DISTRIBUTOR. IF THEY CANNOT GIVE YOU THE NECESSARY SERVICE, WRITE OR PHONE US TO TELL US EXACTLY WHAT DIFFICULTY YOU HAVE EXPERIENCED. BE SURE TO MENTION THE MODEL AND SERIAL NUMBERS.