

INSTRUCTIONS AND PARTS MANUAL

STANDALONE AUTOMATIC HEIGHT CONTROL

CAS-2100 SERIES

Please record your equipment identification information below for future reference. This information can be found on your machine nameplate.

Model Number _____

Serial Number _____

Date of Purchase _____

Whenever you request replacement parts or information on this equipment, always supply the information you have recorded above.

LIT-CAS-2100-IPM-0321

Bug-O Systems is committed to empowering our customers by providing operator controlled mechanized solutions for their welding, cutting and custom applications.



BUG-O SYSTEMS

A DIVISION OF WELD TOOLING CORPORATION



280 TECHNOLOGY DRIVE CANONSBURG, PENNSYLVANIA 15317-9564 USA
PHONE: 412-331-1776 <http://www.bugo.com> FAX: 412-331-0383

SAFETY

PROTECT YOURSELF AND OTHERS FROM SERIOUS INJURY OR DEATH. KEEP CHILDREN AWAY. BE SURE THAT ALL INSTALLATION, OPERATION, MAINTENANCE AND REPAIR PROCEDURES ARE PERFORMED ONLY BY QUALIFIED INDIVIDUALS.



ELECTRIC SHOCK can kill.

- 1) The equipment is not waterproof. Using the unit in a wet environment may result in serious injury. Do not touch equipment when wet or standing in a wet location.
- 2) The unused connectors have power on them. Always keep the unused connectors covered with the supplied protective panels. Operation of the machine without the protective panels may result in injury.
- 3) Never open the equipment without first unplugging the power cord or serious injury may result.
- 4) Verify the customer-supplied power connections are made in accordance with all applicable local and national electrical safety codes. If none exist, use International Electric Code (IEC) 950.
- 5) Never remove or bypass the equipment power cord ground. Verify the equipment is grounded in accordance with all applicable local and national electrical safety codes. If none exist, use International Electric Code (IEC) 950.

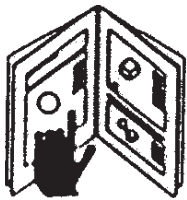

READ INSTRUCTIONS.

Read the instruction manual before installing and using the equipment.



EQUIPMENT DAMAGE POSSIBLE.

- 1) Do not plug in the power cord without first verifying the equipment is OFF and the cord input voltage is the same as required by the machine or serious damage may result.
- 2) Always verify both the pinion and wheels are fully engaged before applying power or equipment damage may occur.
- 3) Do not leave the equipment unattended.
- 4) Remove from the work site and store in a safe location when not in use.



FALLING EQUIPMENT can cause serious personal injury and equipment damage.

Faulty or careless user installation is possible. As a result, never stand or walk underneath equipment.



MOVING PARTS can cause serious injury.

- 1) Never try to stop the pinion from moving except by removing power or by using the STOP control.
- 2) Do not remove any protective panels, covers or guards and operate equipment.

HIGH FREQUENCY WARNINGS

SPECIAL PRECAUTIONS ARE REQUIRED WHEN USING PLASMA, TIG OR ANY WELDING PROCESS THAT USES HIGH FREQUENCY TO STRIKE AN ARC.



WARNING: HIGH FREQUENCY CAN EFFECT MACHINE OPERATION AND THEREFORE, WELD QUALITY.

Read the precautions below before installing and using the equipment.

PRECAUTIONS:

- 1) Some plasma or welding cables are strong sources of high frequency interference. NEVER lay a plasma or welding cable across the controls of the machine.
- 2) Always physically separate the plasma or welding cable leads from the machine cables. For example, the plasma or welding cable leads should NEVER be bundled with a pendant cable or the machine power cord. Maximize the separation between any machine cables and the plasma or welding cables.
- 3) Strictly follow the grounding procedures specified for the plasma or welding unit. NOTE: Some plasma and welding units produce exceptionally large amounts of high frequency noise. They may require a grounding rod be driven into the earth within six feet (2 meters) of the plasma or welding unit to become compatible with an automatic cutting or welding process.
- 4) If the high frequency is produced using a spark gap, adjust the points so the gap is as small as possible. The larger the gap, the higher the voltage and the higher the interference.
- 5) Some plasma or welding units will inject high frequency interference into the AC power line. Use separate power line branches whenever possible to power the plasma or welding source and the machine. Do not plug them into the same outlet box.
- 6) High frequency noise may enter the machine through the plasma or welding supply remote contactor leads. Some plasma and welding sources can produce noise spikes of up to several thousand volts. These sources are not compatible with automated cutting and welding equipment. It is recommended that the remote contactor leads on these plasma or welding sources not be connected to the machine. An alternate solution is to purchase a separate remote contactor isolation box.

STANDALONE AUTOMATIC HEIGHT CONTROL CAS-2100 SERIES

INSTRUCTIONS AND PARTS MANUAL TABLE OF CONTENTS

PAGE

5.....	Introduction / Overview / Available Models / Specifications
6-7	Setup
8.....	CAS-2100 Standalone Torch Height Control
9.....	CAS-1500 Height Slide Assembly / Exploded View / Parts List
10.....	CAS-1550 Hall Effect Current Sensor Assembly / Parts List
11.....	PCB-1213 Adjustment Pot
12.....	CAS-2110 Control Box, AMP Sensing / Exploded View
13.....	CAS-2110 Control Box, AMP Sensing / Parts List
14.....	CAS-2110-WD Control Box, AMP Sensing / Wiring Diagram
15.....	Trouble Shooting
16.....	Warranty



Patents Pending

INTRODUCTION

CAS-2100 Series are Standalone Automatic Height Controls that control the welding tip to work distance and maintain a constant weld current, which assists in providing uniform weld penetration. Available in three models, by voltage. Automatic Height Control senses the actual weld current, compares this value to the set point, and raises or lowers the welding gun accordingly. It features a built-in time delay after the arc is struck, and automatically shuts off when current drops too low (generally below 60 amps).

OVERVIEW

CAS-2100 Standalone Automatic Height Control is a retrofit unit designed to provide Automatic Height Control on BUG-O and other mechanized welding systems. CAS-1500 Height Slide Assembly replaces the welding clamp originally supplied. It requires a 7/8" (22.2 mm) diameter rod for mounting. Likewise the CAS-2110 Control Box is mounted on a 7/8" (22.2 mm) diameter rod. In both instances BUG-O offers many different Torch Supports and Cable Anchor designs to accomplish proper mounting of both units. *Consult BUG-O "Supports and Accessories" or "Heavy Duty Tool Positioning System" brochures for available mounting options.*

AVAILABLE MODELS

CAS-210X Standalone Automatic Torch Height Control Consisting of:

- CAS-1500 Height Slide Assembly
- CAS-1550 Hall Effect Current Sensor Assembly
- CAS-211X Control Box, AMP Sensing

"X" based on Voltage the unit will operate on:

- X = 0 for 120VAC/50/60 Hz/1Ph
- X = 2 for 240VAC/50/60 Hz/1Ph
- X = 4 for 42VAC/50/60 Hz/1Ph

SPECIFICATIONS

Weight (Net):	14.5 lbs (6.6 kg)
Travel:	2" (50.8 mm)
Carrying Capacity:	10 lbs (4.5 kg)
Operating Range:	60 to 500 Amps

ALL BUG-O Automatic Height Controls require a Constant Voltage (CV) Power Source. Consult the factory for your particular application.

SETUP

CAS-2110 Control Box, AMP Sensing

A clamp, BUG-5295 Rod Mount Assembly is provided mounted to the bottom of CAS-2110 Control Box. This Rod Mount requires a 7/8" (22.2 mm) diameter rod for mounting. Typically, customers will mount the Control Box to the "Cable Mounting Assembly" already on the BUG-O. Consult with your Local Bug-O distributor or the factory for assistance if you require help with mounting the control box.

CAS-1500 Height Slide Assembly

A clamp, CAS-1510 Dual Position Clamp Block is provided mounted to the bottom of the Height Slide Assembly. This Clamp Block requires a 7/8" (22.2 mm) diameter rod for mounting. Typically, clients mount the Height Slide Assembly to the welding group already on the BUG-O. Consult with your Local Bug-O distributor or the factory for assistance if you require help with mounting the control box.

Position and clamp welding gun with CAS-1500 installed on Welding Torch Mounting Group, secure welding gun in the clamp located on the end of the Height Slide Assembly. Arrange cables so that they do not interfere with the movement of the machine before securing the cable in the cable anchor at the rear of the machine.

Connect Control Cables

Connect weld contact outlet, pins A&B on the unit, to the wire feeder contact circuit.

Install Current Sensor

Connect CAS-1550 Hall Effect Current Sensor "in-line" on either the welding power source ground cables or the positive electrode cable (Torch Cable). As long as one lead of the CAS-1550 is connected to the work piece and the other lead is connected to the power source, the system will function properly.

Plug in the CAS System

Inspect power cord before each use. Do not use if damaged. Plug in the machine to a power receptacle of the appropriate voltage.

Power ON the Drive System with AHC

CAUTION: machine may start moving as soon as it is powered "ON." Use the power switch on the Drive Unit to turn the power "ON" and "OFF" to the machine. For operator safety, set the Drive Unit to "OFF" before turning on the machine.

Position Welding Gun

Proper setup of the welding gun is critical to a successful weld. In addition to manually positioning the welding gun within the clamp, the welding gun must also be properly set with respect to three mechanical controls: The Welding Mounting Group, the Automatic Height Controller (**AHC**) and the tractor position.

Height Slide Assembly: The slide assembly has 2" (50.8 mm) of travel available. For best results, position the slide assembly in the middle of the total range before setting the welding gun. Use the torch manual jog switch (located on CAS-2110 Control Box) to position the height slide.

Tractor Position: Use the tractor "Forward/ Off/ Reverse" switch to position drive unit with AHC at the start of the weld. The operator can increase or decrease the tractor travel speed at any time using the speed control on the drive unit.

SETUP, CONT'D

Welder, Wire-feeder, Welding Gun, Weld and Automatic Height Control Setup

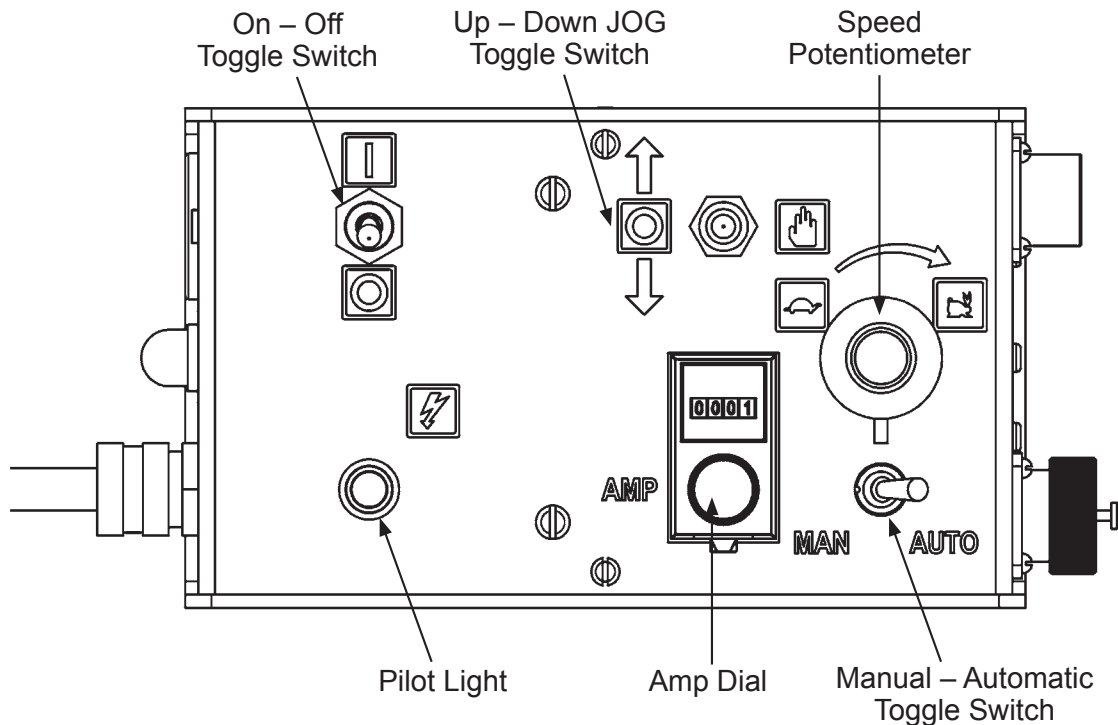

CAS-2110 CONTROL BOX

MAKE SURE THE WELDING POWER SOURCE is a Constant Voltage model and that it is in **CV MODE!!!** If your welding power source is not or does not have a Constant Voltage option the Automatic Height Control WILL NOT WORK!

To set your AUTOMATIC HEIGHT CONTROL:

(Reference CAS-2110 Control Box)

- Connect CAS-1550 Hall Effect Sensor Box in-line on negative work lead (ground cable)
- Set the height control (**Manual - Automatic Toggle Switch**) to manual mode.
- Set the torch height manually (**Up - Down JOG Toggle Switch**) to where you want it.
- Make a small weld and record the AMP reading from the power source.
- Now, dial this number, AMP reading, into the Height Control (**Amp Dial**).
- Turn the height control (**On - Off Toggle Switch**) back on.
- Run the system and it should run at the same height and thus current.

If the above does not work, it is possible that the slide on the Height Control is reacting opposite from what it should.

If this happens;

- Physically turn the slide over, or reverse the motor leads.
- Then repeat the “running procedure” above again.
 - If it works now, check that (**Up - Down JOG Toggle Switch**) work in the proper direction. If not, they can be fixed by rotating the switch in the panel, 180 degrees.

If this does not work please consult “Trouble Shooting Page” in the back of this manual.

The operator can temporarily override Automatic Height Control using the manual jog switch on CAS-2110 Control Box while welding. AHC resumes as soon as the jog switch is released. To disable the AHC, move the Manual -- Automatic Toggle Switch on the CAS-2110 Control Box to manual.

CAS-2100 SERIES STANDALONE AUTOMATIC HEIGHT CONTROL

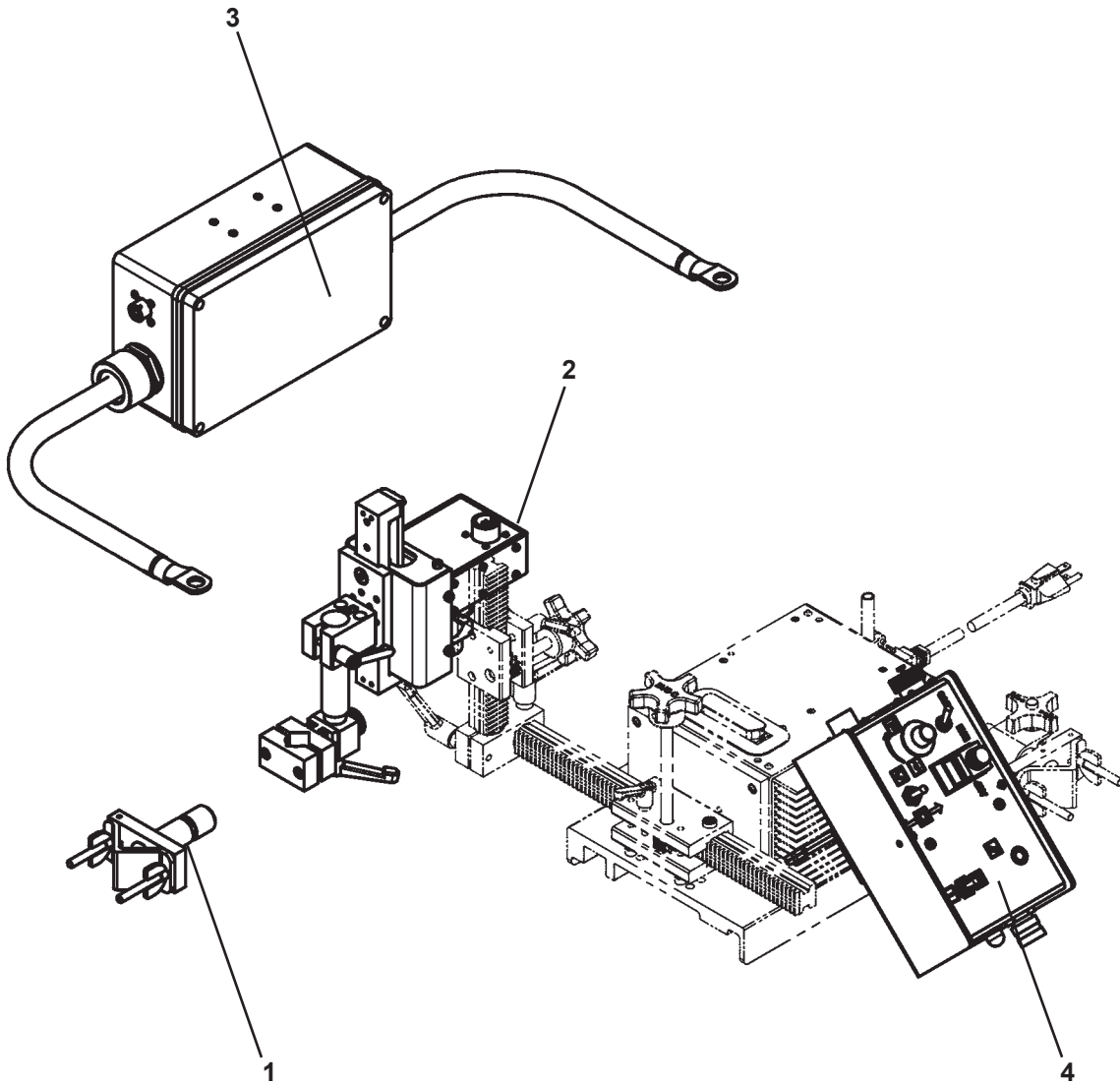

<u>ITEM</u>	<u>QTY</u>	<u>PART NO.</u>	<u>DESCRIPTION</u>
1	1	BUG-2708	Clamp with 7/8" Rod (22.2 mm)
2	1	CAS-1500	Height Slide Assembly
3	1	CAS-1550	Hall Effect Sensor Assembly
4	1	CAS-2110	Control Box, AMP Sensing

CAS-1500 HEIGHT SLIDE ASSEMBLY / EXPLODED VIEW / PARTS LIST

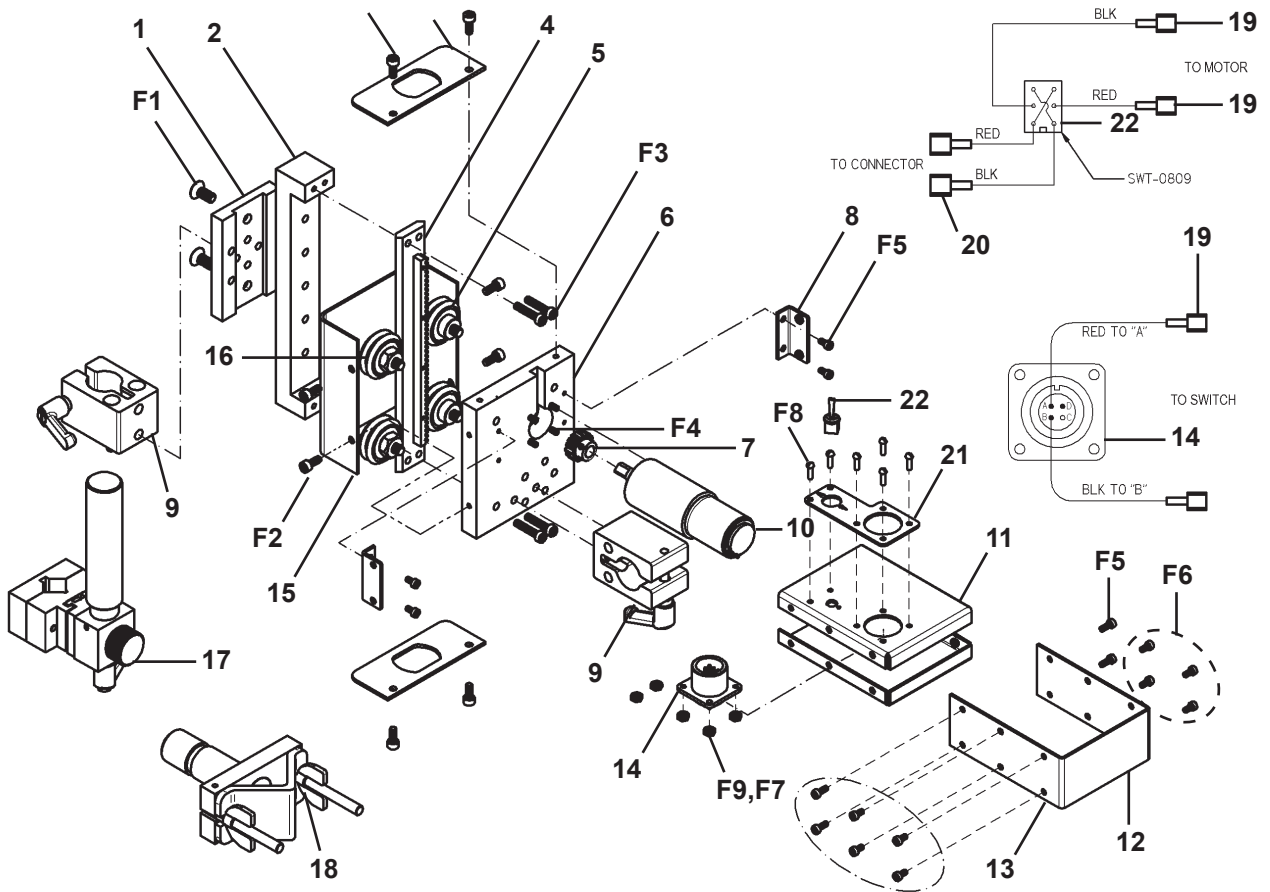

<u>ITEM</u>	<u>QTY</u>	<u>PART NO.</u>	<u>DESCRIPTION</u>
1	1	CAS-1512	Torch Mount Plate
2	1	CAS-1509	Height Arm Mounting Bar
3	2	CAS-1523	End Cap
4	1	CAS-1505	Height Arm Assembly
5	2	PWS-1028	Fixed Wheel & Leg Assembly
6	1	CAS-1522	Mounting Plate
7	1	CAS-1511	Steel Pinion
8	2	CAS-1517	CAS Drive Motor Cover Mount Angle
9	2	CAS-1510	Dual Position Clamp Block
10	1	PRS-1025	Motor
11	1	CAS-1518	CAS Drive Motor Cover Panel A
12	1	CAS-1521	CAS Drive Motor Outer Cover
13	1	CAS-1519	CAS Drive Motor Cover Panel B
14	1	BUG-1034	Panel Connector, 4-T, M
15	1	CAS-1503-P	Arm Cover
16	2	PWS-1029	Adjustable Wheel & Leg Assembly
17	1	CAS-1590	Torch Holder Assembly
18	1	BUG-2708	Clamp
19	4	GOF-3036	Qd Female, Fully Insulated
20	2	GOF-3037	Terminal, QD, Insulated
21	1	AVC-2116	Amp-Volt, Legend Plate
22	1	SWT-0809	Toggle Switch, DPDT, On-None-On
F1	2	MET-0975-SS	Flt Hd Soc Scr M6 x 14
F2	8	MET-0553-SS	Soc Hd Cap Scr M4 x 10
F3	4	MET-0559-SS	Soc Hd Cap Scr M4 x 20
F4	4	MET-0147-SS	Pan Hd Phil Scr M3 x 16
F5	8	MET-0542-SS	Soc Hd Cap Scr M3 x 8
F6	8	MET-0541-SS	Soc Hd Cap Scr M3 x 6
F7	6	FAS-1305	Hex Nut # 4-40
F8	6	FAS-1204	But Hd Sk Hd Scr # 4-40 x 3/8
F9	6	WAS-0201	#4 Internal Star Lockwasher
*	1	CAS-1557	Control to Slide Cable 3ft

* Not Shown

CAS-1550 HALL EFFECT SENSOR ASSEMBLY / PARTS LIST

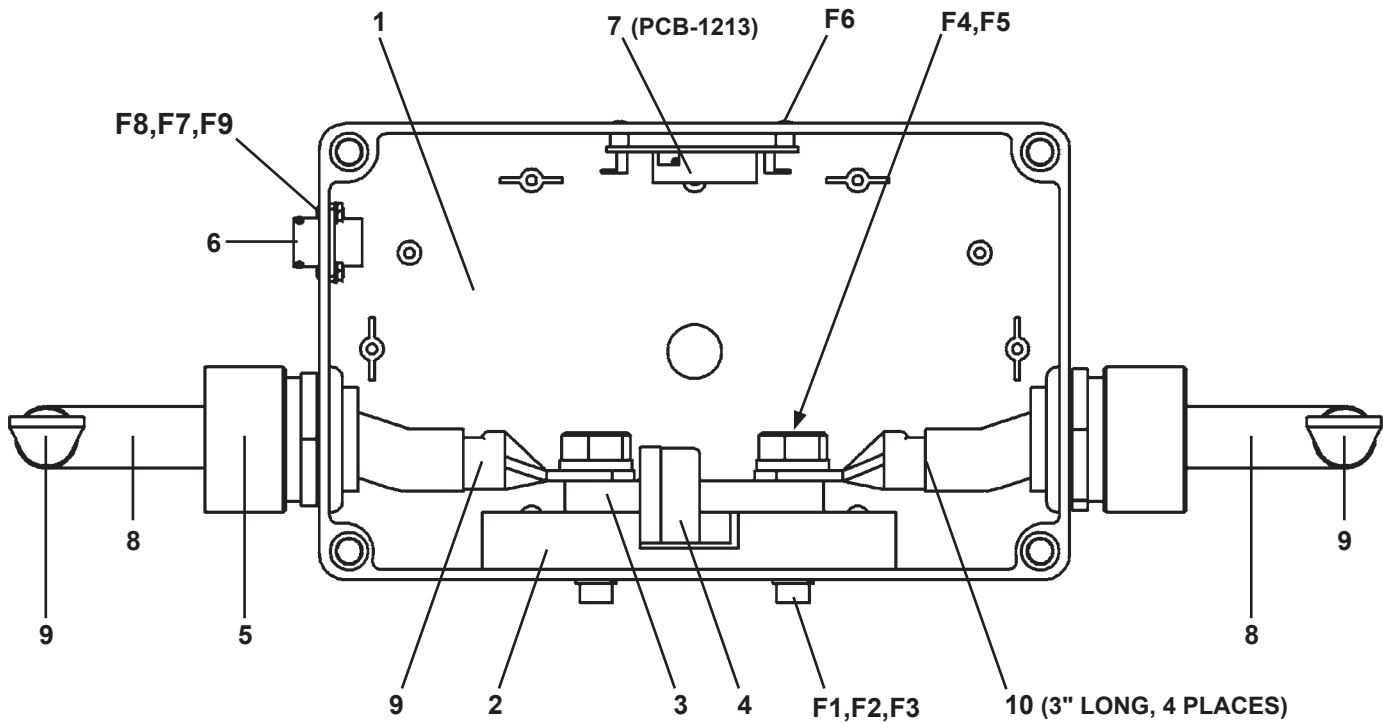

<u>ITEM</u>	<u>QTY</u>	<u>PART NO.</u>	<u>DESCRIPTION</u>
1	1	CAS-1552	Hall Effect Current Sensor Assembly
2	1	PWS-0303	Insulator Block
3	1	PWS-0304	Brass Current Bar
4	1	CAS- 1551	500A Current Sensor
5	2	PWS-0307	1" Cord Grip .63" to .75" Cable
6	1	PWS-0305	Main Current Sense Harness
*	1	PWS-0306	Sensor Harness
7	1	PCB-1213	Hall Effect Interface Board
8	2 x 20	CWO-6001	2/0 Weld Cable
9	4	CWO-8061	Lug, 1/0-2/0 Welding
10	12"	CWO-6029	Heat Shrink Tube
F1	2	MET-0578-SS	Soc Hd Cap Scr M6 x 18
F2	2	WAS-0243	1/4" Split Lock Washer
F3	2	WAS-0240	1/4" Sae Flat
F4	2	FAS-2301	Hex Hd Cap Scr 1/2-13 x 1-1/4"
F5	2	WAS-0281	1/2" Split Lock Washer
F6	4	MET-0141-SS	Pan Hd Phil Scr M3 x 6
F7	4	WAS-5541-SS	M3 Lock Washer
F8	4	MET-1340-SS	M3 Hex Nut
F9	4	MET-0143-SS	Pan Hd Phil Scr M3 x 10

* Not Shown

PCB-1213 ADJUSTMENT POT

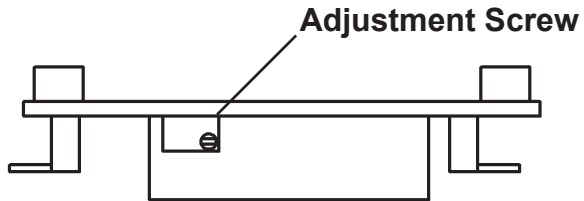

The **Amp Dial** setting from **CAS-2110 Control Box** may not exactly match the **Amp Dial** on the power source. If precise matching is important, one can calibrate the system so that they match using the **Adjustment Pot (PCB-1213)** found inside the CAS-1550 Hall Effect Sensor Assembly.

While the system is welding and the Auto Height Control is “ACTIVE”, turn the **Adjusting Screw** using a small “Jeweler’s Style” screw driver.

As this screw is turned, the **Amp Dial** on the power source will change. When the display on the welding power source matches the **Amp Dial** setting, the system is calibrated.

NOTE: This adjustment is not normally needed.

CAS-2110 CONTROL BOX, AMP SENSING / EXPLODED VIEW

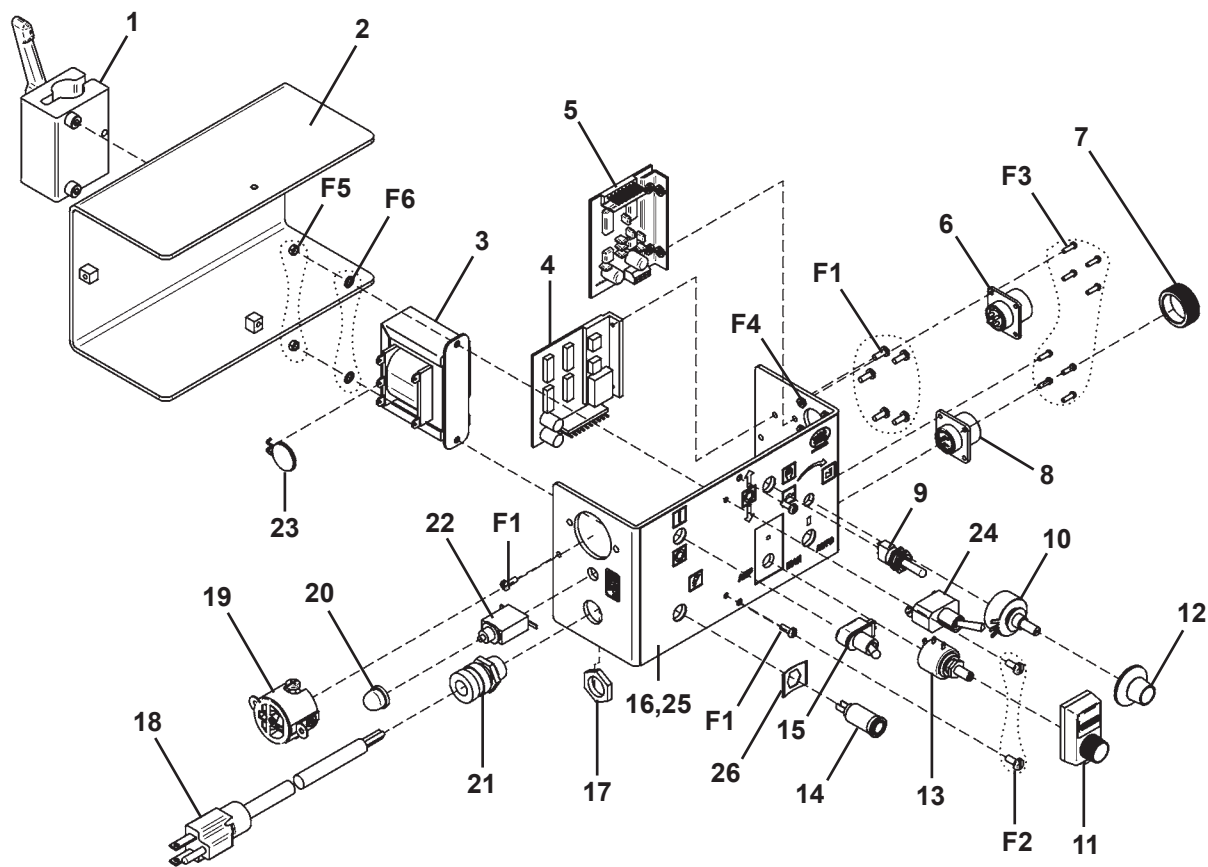

CAS-2110 CONTROL BOX, AMP SENSING / PARTS LIST

<u>ITEM</u>	<u>QTY</u>	<u>PART NO.</u>	<u>DESCRIPTION</u>
1	1	BUG-5295	Rod Mount Assembly
2	1	CAS-1019	Rear Cover
3	1	BUG-5001**	Transformer
4	1	CAS-1770	Speed Control (Iron Rotor)
5	1	CAS-1060-500	Arc Sensing Control Board
6	1	MUG-1156	Panel Connector, 4-T, F
7	1	BUG-9628	Cap & Chain Assembly
8	1	BUG-9856	Panel Connector, 2-T, F
9	1	BUG-5323	SPDT, Toggle, (ON)-OFF-(ON)
10	1	BUG-9677	Potentiometer
11	1	BUG-9676	Dial Counter
12	1	BUG-9621	Knob, Straight Molded Phenolic
13	1	BUG-1572	Pot
14	1	BUG-1415**	Pilot Light
15	1	ABP-1069	Toggle Switch
16	1	CAS-2111	Front Panel, Hall Effect
17	1	FAS-3150	Nut, Cord Grip
18	1	BUG-9445**	Power Cord (120V Shown)
19	1	BUG-5321**	Single Power Receptacle
20	1	BUG-2924	Reset Seal, Transparent
21	1	BUG-9446	Cord Grip
22	1	BUG-2923**	Circuit Breaker
23	1	BUG-1393**	Volt Trap
24	1	BUG-2626	SPDT, ON-NONE-ON
25	1	CAS-2113	Legend Plate Hall Effect
26	1	BUG-1415-A	Speed Nut
F1	8	FAS-0114	Pan Hd Scr 6-32 x 3/8 BLACK
F2	2	FAS-0124	8-32 x 3/8 PAN Hd, Di-Chrome
F3	8	FAS-0204	Rnd Hd Slit Scr 4-40 x 3/8 Zinc
F4	8	FAS-1305	Hex Nut 4-40
F5	2	FAS-1320	Hex Nut 8-32
F6	2	WAS-0221	#8 Internal Star Lockwasher
*	1	BUG-2005	Label/BUG-O
*	1	BUG-9234**	Voltage Label
*	1	CAS-1010-WG	Wire Group
*	1	CNN-0228	Housing 8 Pin

* Item Not Shown

**See Wiring Diagram for 240VAC & 42VAC Part Numbers

CAS-2110-WD CONTROL BOX, AMP SENSING / WIRING DIAGRAM

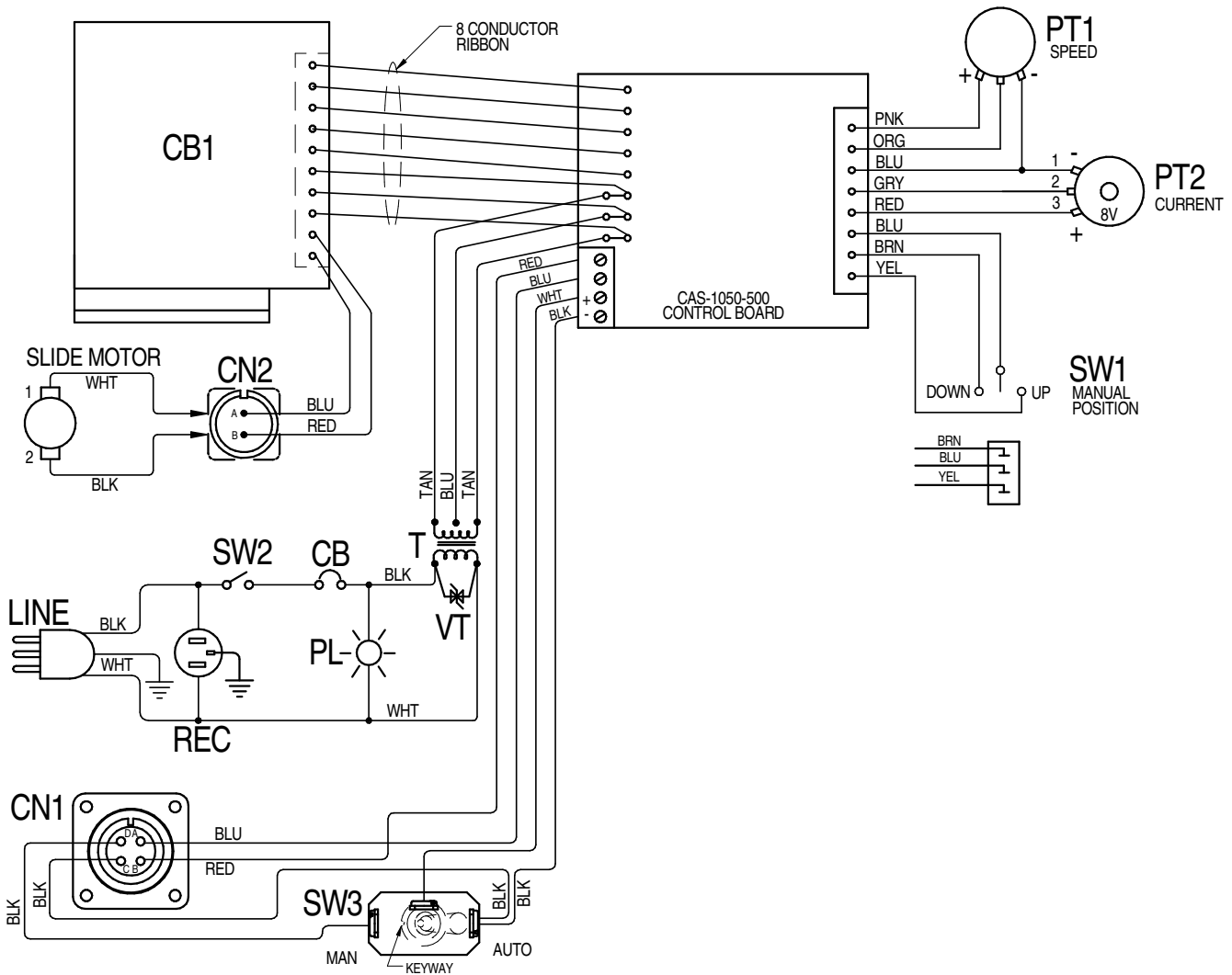

ITEM	POWER SOURCE			DESCRIPTION
	120 VAC	240 VAC	42 VAC	
CB	BUG-2923	BUG-2952	BUG-2933	Circuit Breaker
LINE	BUG-9445	GOF-3115	BUG-9442	Power Cord (120V shown)
PL	BUG-1415	BUG-1428	BUG-1427	Pilot Light
REC	BUG-5321	BUG-9595	BUG-5321	Power Receptacle (120V shown)
T	BUG-5001	BUG-5002	BUG-5003	Transformer
VT	BUG-1393	BUG-1563	BUG-1393	Volt Trap
CB1	CAS-1770			Speed Control (Iron Motor)
CB2	CAS-1060-500			Arc Sensing Control Board
CN1	MUG-1156			Panel Connector, 4-T, F
CN2	BUG-9856			Panel Connector, 2-T, F
PT1	BUG-9677			Potentiometer 10K
PT2	BUG-1572			5-Turn 10K Pot
SW1	BUG-5323			SPDT, Toggle, (ON)-OFF-(ON)
SW2	ABP-1069			Toggle Switch
SW3	BUG-2626			SPDT, ON-NONE-ON

TROUBLESHOOTING

If the setting is lower than that of the actual welding current, the Height Control should back out of the joint. If the setting is higher than that of the actual welding current, the Height Control should dive into the joint. To test set 100 Amp setting (no less than 100 to avoid minimum) and a close stick-out, Height Control should back out. 500 Amp and a large stick-out and the Height Control should dive in.

If you cannot fix Automatic Height Control with the above information, please provide the following:

1. How old is the system?
2. Did it ever work correctly?
3. Does the height slide move up & down in the proper directions when jogged in manual mode?
4. Do they have the CAS-1550 Hall Effect sensor box connected in-line on negative work lead (ground cable)?
5. Is the welding power source CV (constant voltage)?
6. Give some indication on how it failed the above procedures.

WARRANTY

Limited 3-Year Warranty

MODEL _____
SERIAL NO. _____
DATE PURCHASED: _____
WHERE PURCHASED: _____

For a period ending one (1) year from the date of invoice, Manufacturer warrants that any new machine or part is free from defects in materials and workmanship and Manufacturer agrees to repair or replace at its option, any defective part or machine. HOWEVER, if the invoiced customer registers the Product Warranty by returning the Warranty Registration Card supplied with the product within 90 days of the invoice date, or by registering on-line at www.bugo.com, Manufacturer will extend the warranty period an additional two (2) years which will provide three (3) total years from the date of original invoice to customer. This warranty does not apply to machines which, after Manufacture's inspection are determined by Manufacturer to have been damaged due to neglect, abuse, overloading, accident or improper usage. All shipping and handling charges will be paid by the customer.

The foregoing express warranty is exclusive and Manufacturer makes no representation or warranty (either express or implied) other than as set forth expressly in the preceding sentence. Specifically, Manufacturer makes no express or implied warranty of merchantability or fitness for any particular purpose with respect to any goods. Manufacturer shall not be subject to any other obligations or liabilities whatsoever with respect to machines or parts furnished by Manufacturer.

Manufacturer shall not in any event be liable to Distributor or any customer for any loss of profits, incidental or consequential damages or special damages of any kind. Distributor's or customer's sole and exclusive remedy against Manufacturer for any breach of warranty, negligence, strict liability or any other claim relating to goods delivered pursuant hereto shall be for repair or replacement (at Manufacturer's option) of the machines or parts affected by such breach.

Distributor's Warranty:

In no event shall Manufacturer be liable to Distributor or to any customer thereof for any warranties, representations or promises, express or implied, extended by Distributor without the advance written consent of Manufacturer, including but not limited to any and all warranties of merchantability or fitness for a particular purpose and all warranties, representations or promises which exceed or are different from the express limited warranty set forth above. Distributor agrees to indemnify and hold Manufacturer harmless from any claim by a customer based upon any express or implied warranty by Distributor which exceeds or differs from Manufacturer's express limited warranty set forth above.

HOW TO OBTAIN SERVICE:
IF YOU THINK THIS MACHINE IS NOT OPERATING PROPERLY, RE-READ THE INSTRUCTION MANUAL CAREFULLY, THEN CALL YOUR AUTHORIZED BUG-O DEALER/DISTRIBUTOR. IF THEY CANNOT GIVE YOU THE NECESSARY SERVICE, WRITE OR PHONE US TO TELL US EXACTLY WHAT DIFFICULTY YOU HAVE EXPERIENCED. BE SURE TO MENTION THE MODEL AND SERIAL NUMBERS.