

INSTRUCTIONS AND PARTS MANUAL

COMPACT WALL-FOLLOWING FILLET WELDER

K-BUG 4000
K-BUG 4002
K-BUG 4004

Please record your equipment identification information below for future reference. This information can be found on your machine nameplate.

Model Number _____

Serial Number _____

Date of Purchase _____

Whenever you request replacement parts or information on this equipment, always supply the information you have recorded above.

LIT-KBUG-4000-IPM-1119

Bug-O Systems is committed to empowering our customers by providing operator controlled mechanized solutions for their welding, cutting and custom applications.

B U G - O S Y S T E M S

A DIVISION OF WELD TOOLING CORPORATION



280 TECHNOLOGY DRIVE CANONSBURG, PENNSYLVANIA 15317-9564 USA
PHONE: 412-331-1776 <http://www.bugo.com> FAX: 412-331-0383



SAFETY

PROTECT YOURSELF AND OTHERS FROM SERIOUS INJURY OR DEATH. KEEP CHILDREN AWAY. BE SURE THAT ALL INSTALLATION, OPERATION, MAINTENANCE AND REPAIR PROCEDURES ARE PERFORMED ONLY BY QUALIFIED INDIVIDUALS.



ELECTRIC SHOCK can kill.

- 1) The equipment is not waterproof. Using the unit in a wet environment may result in serious injury. Do not touch equipment when wet or standing in a wet location.
- 2) The unused connectors have power on them. Always keep the unused connectors covered with the supplied protective panels. Operation of the machine without the protective panels may result in injury.
- 3) Never open the equipment without first unplugging the power cord or serious injury may result.
- 4) Verify the customer-supplied power connections are made in accordance with all applicable local and national electrical safety codes. If none exist, use International Electric Code (IEC) 950.
- 5) Never remove or bypass the equipment power cord ground. Verify the equipment is grounded in accordance with all applicable local and national electrical safety codes. If none exist, use International Electric Code (IEC) 950.

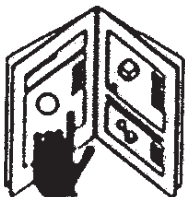

READ INSTRUCTIONS.

Read the instruction manual before installing and using the equipment.



EQUIPMENT DAMAGE POSSIBLE.

- 1) Do not plug in the power cord without first verifying the equipment is OFF and the cord input voltage is the same as required by the machine or serious damage may result.
- 2) Always verify both the pinion and wheels are fully engaged before applying power or equipment damage may occur.
- 3) Do not leave the equipment unattended.
- 4) Remove from the work site and store in a safe location when not in use.



FALLING EQUIPMENT can cause serious personal injury and equipment damage.

Faulty or careless user installation is possible. As a result, never stand or walk underneath equipment.



MOVING PARTS can cause serious injury.

- 1) Never try to stop the pinion from moving except by removing power or by using the STOP control.
- 2) Do not remove any protective panels, covers or guards and operate equipment.

HIGH FREQUENCY WARNINGS

SPECIAL PRECAUTIONS ARE REQUIRED WHEN USING PLASMA, TIG OR ANY WELDING PROCESS THAT USES HIGH FREQUENCY TO STRIKE AN ARC.



WARNING: HIGH FREQUENCY CAN EFFECT MACHINE OPERATION AND THEREFORE, WELD QUALITY.

Read the precautions below before installing and using the equipment.

PRECAUTIONS:

- 1) Some plasma or welding cables are strong sources of high frequency interference. NEVER lay a plasma or welding cable across the controls of the machine.
- 2) Always physically separate the plasma or welding cable leads from the machine cables. For example, the plasma or welding cable leads should NEVER be bundled with a pendant cable or the machine power cord. Maximize the separation between any machine cables and the plasma or welding cables.
- 3) Strictly follow the grounding procedures specified for the plasma or welding unit.
NOTE: Some plasma and welding units produce exceptionally large amounts of high frequency noise. They may require a grounding rod be driven into the earth within six feet (2 meters) of the plasma or welding unit to become compatible with an automatic cutting or welding process.
- 4) If the high frequency is produced using a spark gap, adjust the points so the gap is as small as possible. The larger the gap, the higher the voltage and the higher the interference.
- 5) Some plasma or welding units will inject high frequency interference into the AC power line. Use separate power line branches whenever possible to power the plasma or welding source and the machine. Do not plug them into the same outlet box.
- 6) High frequency noise may enter the machine through the plasma or welding supply remote contactor leads. Some plasma and welding sources can produce noise spikes of up to several thousand volts. These sources are not compatible with automated cutting and welding equipment. It is recommended that the remote contactor leads on these plasma or welding sources not be connected to the machine. An alternate solution is to purchase a separate remote contactor isolation box.

COMPACT WALL-FOLLOWING FILLET WELDER K-BUG 4000, K-BUG 4002 INSTRUCTIONS AND PARTS MANUAL

TABLE OF CONTENTS

PAGE

5.....	Introduction
5.....	Features
5.....	Technical Data
5.....	Dimensions
6.....	User Interface
6.....	Welding Modes
7.....	Intermittent Welding
7.....	Intermittent Welding Lock Out
7.....	Stop Sensor Operation
8.....	Time Settings
8.....	Global Parameters
9.....	Converting Units
10.....	Installation and Operation
10.....	Maintenance
11-12.....	Troubleshooting
13.....	K-BUG 4000 Assembly View
14.....	K-BUG 4000 Wiring Diagram
15.....	KBUG-4010 Carriage Assembly / Exploded View
16.....	KBUG-4010 Carriage Assembly / Parts List
17.....	KBUG-1060 Guide Arms / Exploded View / Parts List
17.....	KBUG-4090 Torch Clamp Assembly / Parts List
18.....	KBUG-4050 Control Panel Assembly / Exploded View / Parts List
18.....	Accessories
19.....	SBG-450 Gun & Cable Assembly / Exploded View / Parts List
20.....	Warranty

INTRODUCTION

The K-BUG 4000 is a compact, light weight, wall-travelling unit designed to mechanize horizontal fillet welding. It is able to follow vertical or inclined walls of straight or curved (R > 1000 mm) profile. The machine is capable of performing continuous and intermittent (stitch) welds.

FEATURES

- Compact - 14.6 x 8.9 x 11.3 in (370 x 226 x 288 mm)
- Lightweight - 14 lb (6.4 kg)
- Continuous and intermittent welds
- Digital speed display
- Precision speed control for consistent weld quality
- User adjustable time settings for puddle build-up, pause time and crater-fill
- Drive wheels rated to 400 °F (204 °C)

TECHNICAL DATA

Power Input

K-BUG 4000 120VAC / 50-60 Hz / 1 Phase

K-BUG 4002 240VAC / 50-60 Hz / 1 Phase

K-BUG 4004 42VAC / 50-60 Hz / 1 Phase

Weight 14 lb (6.4 kg)

Drive Motor 24 VDC, 12 W, 5000 RPM

Travel Speed 0.3 - 77 in/min (0.1 - 195 cm/min)

Torch Holder Fits barrels up to 0.75 in (19 mm)

Torch Angle Adjustable

Running Angle 90°



Bug-O Systems has a complete overview video of our K-BUG 4000. To watch this video, scan the qr code or visit: <https://www.youtube.com/watch?v=XPUmWPYU5EU&t=5s>

DIMENSIONS

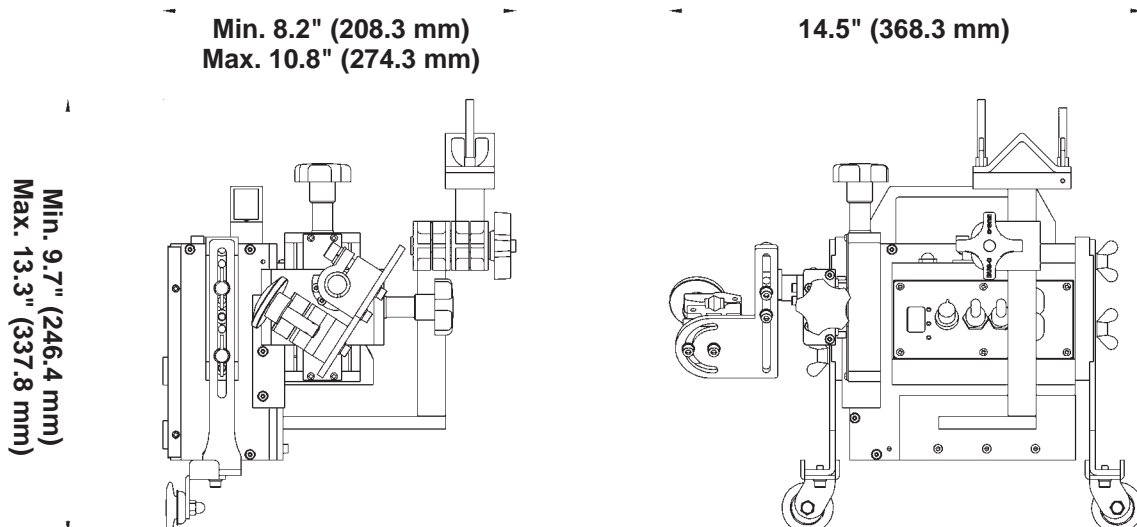

USER INTERFACE

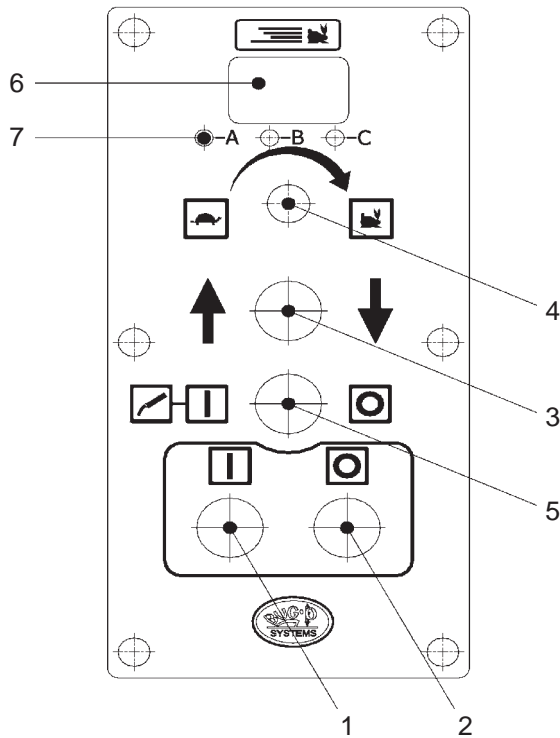

- 1. Cycle Start Button** - Push button to initiate weld cycle. Weld contact will close, according to time settings, if the Weld Switch is set to Auto, the carriage will travel in the direction selected by the Travel Direction Switch.
- 2. Cycle Stop Button** - Push button to stop welding cycle.
- 3. Travel Direction Switch** - Set switch to determine direction of carriage travel.
- 4. Speed Adjustment Knob** - Rotate knob to adjust carriage travel speed. Turning clockwise (right) will INCREASE speed.
NOTE: Travel Speed Adjustment Knob is also used for setting the INTERMITTENT WELDING function (pg.7) and the time settings.
- 5. Weld Auto / Off Contactor** - When switched to AUTO, weld contact will close with cycle start. Switched to the right, weld contact will remain open upon cycle start.
- 6. Digital Speed Display** - Numerically displays real-time travel speed in in/min (cm/min). Also displays parameters during setup of intermittent function and time settings.
- 7. Indicator LED's** - Indicate active parameter during intermittent welding.
 - A. Weld Length
 - B. Non-Weld Length
 - C. Total Length

WELDING MODES

The K-BUG 4000 offers three weld modes - Continuous, Total Length Intermittent and User Defined Intermittent. The value shown in the speed display will vary based on what welding mode the machine is operating in. Speed is displayed *only* during Continuous welding

- 1. Continuous Welding**
 - No LED's lit when Cycle Start button is pressed
 - Displays speed while welding (0.1 in/min)
- 2. User Defined Intermittent Welding**
 - A or B LED lit when Cycle Start button is pressed
 - User sets Welding Speed before pressing Cycle Start button
 - Display will countdown each program parameter in order
 - With A LED lit, the display will countdown Puddle Build-up timer, u, then Weld On distance, A, then Crater Fill timer, n.
 - With B LED lit, the display will countdown Weld Off distance, B
 - **NOTE:** Machine travels at higher speed during Non-Welding travel
 - The intermittent cycle will repeat until the user presses Cycle Stop button or the Stop Sensor is tripped

WELDING MODES, CONT'D.

3. Total Length Intermittent Welding

- C LED lit when Cycle Start button is pressed
 - User sets Welding Speed before pressing Cycle Start button
 - Display will countdown total distance remaining (1.0 in)
 - A or B LED will light as appropriate for welding mode
- NOTE:** Machine travels at higher speed during Non-Welding travel
- The intermittent cycle will continue until the Total Length is satisfied or the Stop Sensor is tripped

INTERMITTENT WELDING

The Travel Speed Adjustment Knob is used for entering the parameters for intermittent or stitch welding. Follow the steps below to enter the welding parameters.

1. Press the Travel Speed Adjustment Knob. The A LED will illuminate.
2. Turn the Travel Speed Adjustment Knob (clockwise + / counterclockwise -) to set the WELD LENGTH. The length adjusts.*
3. Press the Travel Speed Adjustment Knob again. The B LED will illuminate.
4. Turn the Travel Speed Adjustment Knob to set the NON-WELD LENGTH. The length adjusts.*
5. Press the Travel Speed Adjustment Knob again. The C LED will illuminate.
6. Turn the Travel Speed Adjustment Knob to set the TOTAL LENGTH. The length adjusts.*
7. Press the travel Speed Adjustment Knob again. All LEDs are unlit.

*Note: measurement is in inches or cm. according to the unit setting - refer to Converting Units on pg.9.

Intermittent Welding is available in two forms - User Defined and Total Length. With User Defined welding, user enters values for Weld Length and Non-Weld Length. Either A or B LED must be lit when pressing Cycle Start Button. Intermittent Weld continues until user presses Cycle Stop Button.

For Total Length welding, user enters values for all three stitch parameters. C LED must be lit when pressing Cycle Start Button. Intermittent welding ends when Total Length has been met.

INTERMITTENT WELDING LOCK OUT

To lock out the intermittent (stitch) welding controls, press and hold the Travel Speed Adjustment knob for three (3) seconds. All of the LEDs will flash. To unlock the intermittent welding controls, press and hold the Travel Speed Adjustment Knob for three (3) seconds. While in lockout, the machine will be unable to perform intermittent welding.

STOP SENSOR OPERATION

The K-BUG 4000 is equipped with a magnetic proximity sensor, mounted internal to the carriage, on the non-torch side. When the sensor detects the end of the work piece, it stops carriage travel and initiates weld shutdown (crater fill).

TIME SETTINGS

The K-BUG 4000 offers three adjustable time settings - Puddle Build-Up, Pause Time and Crater Fill. The Travel Speed Adjustment knob is used for setting each of the timers, as described below.

Puddle Build-up Time (u)

1. While pressing the Cycle Start button, connect the power cord to an appropriate power supply.
2. The Display will show "u0.0" flashing.
3. Turn the Travel Speed Adjustment knob until the desired build-up time is displayed.
4. Default setting is 1.0 seconds. Available range is 0.0 - 9.9 seconds.

Crater Fill Time (n)

1. Press Cycle Start button once more.
2. The Display will show "n0.0" flashing.
3. Turn the Travel Speed Adjustment knob until the desired crater fill time is displayed.
4. Default setting is 1.0 seconds. Available range is 0.0 - 9.9 seconds.

Pause Time (E). After welding, a brief rest before Crater Fill.

1. Press the Cycle Start button once more.
2. The Display will show "E0.0" flashing.
3. Turn the Travel Speed Adjustment knob until the desired stop time is displayed.
4. Default setting is 0.5 seconds. Available range is 0.0 - 9.9 seconds.

When finished setting times, press the Cycle Stop button to exit time setup mode. The machine is now ready to be setup for welding.

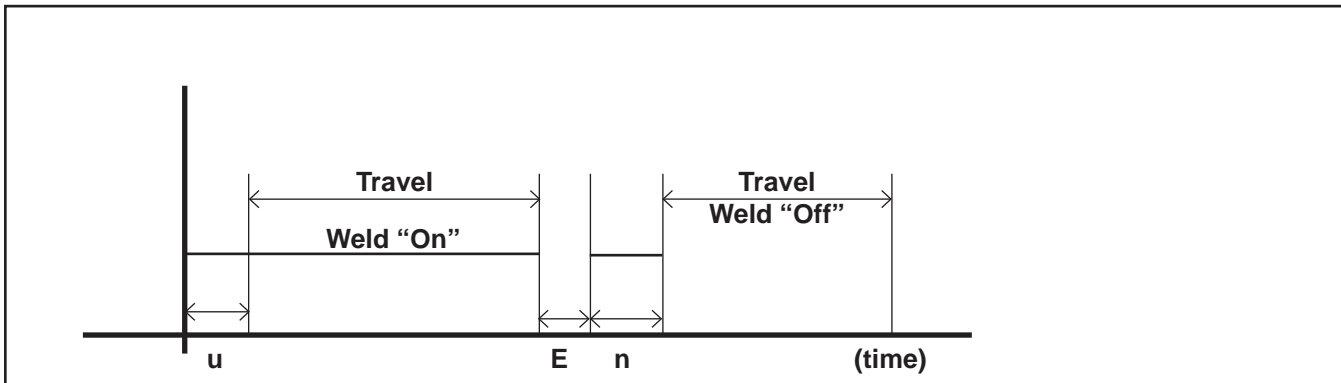

A graphic display of the user adjustable time settings.

GLOBAL PARAMETERS

A menu of Global Parameters is maintained in the K-BUG 4000. The menu consists of six (6) items as described in Table 1, below. Access to the menu is locked when DIP Switch #1 is in the OFF Position.

Table 1: Global Parameters

Display	Description	Default	Range	Units
n.0*	Travel Speed Coefficient	1.0	0.1, 1.0, 2.0, 2.5, 5.0, 10.0	cm/mn, in/min
n.1	Motor Overload Stop Time	2	0.0 - 9.9	sec
n.2*	Travel Motor Reduce Ratio	40	20 - 200	base fig x 10 : 1
n.3*	Diameter of Travel Wheel	50	0.0 - 99.9	mm
n.4	Show Mode	off	off / on	
n.5	Operating Units	U2	U1 / U2	U1 (cm/min), U2 (in/min)

* Indicates parameters NOT to be changed by the User. Changing these parameters can harm machine performance.

GLOBAL PARAMETERS, CONT'D

ACCESS THE GLOBAL PARAMETER MENU

1. With machine unplugged from A/C power supply, remove the six (6) screws securing the Control Interface (Legend Plate and Main PCB) to the Control Panel.
2. Remove the Control Interface and turn it over.
3. Locate DIP Switch 1 and 2 on the Main PCB, see illustration at right.
4. Turn DIP Switch 1 to the "ON" position.
5. Turn over Control Interface. And secure to Control panel.
6. Plug in machine to A/C power supply of appropriate voltage.
7. "0" should be shown in the Display.
8. Press and release Cycle Start button to cycle through the six parameters (0, 1, 2, 3, 4, 5).
9. Use the Travel Speed Adjustment knob to change the parameter setting.
10. When finished, unplug machine, remove Control Interface and turn it over.
11. Turn DIP switch 1 to the "OFF" position to lock global parameter menu.
12. Re-assemble Control Panel and plug in machine to begin operation.

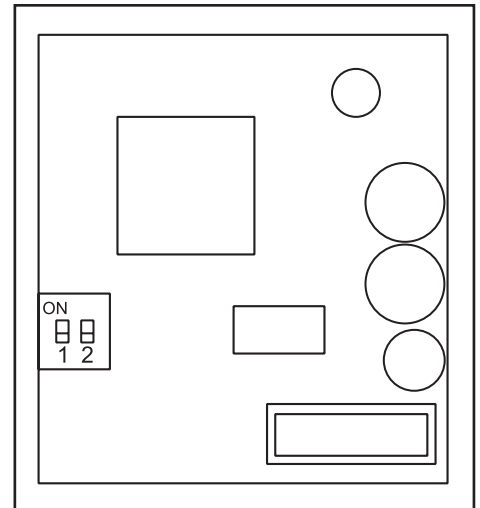

Rear of Main PCB. Note DIP switch placement on left hand side. Move Switch 1 up to the ON position.

CONVERTING UNITS

By default, the K-BUG 4000 will be factory set to operate in English units (in/min) and the K-BUG 4002 will be set to operate in Metric units (cm/min). If it is necessary to change units, follow the steps to access the Global Parameters Menu, above. Use the Cycle Start button until "5" is shown on the Display. Turn the Travel Speed Adjustment knob right or left to select the desired Units. Choose "U1" for Metric (cm/min) or "U2" for English (in/min).

INSTALLATION AND OPERATION

1. Welding Preparation - Secure the necessary welding supplies
 - Welding Power Source (3 phase, 440/380/220V AC)
 - Wire Feeder
 - Tank of appropriate shielding gas, with pressure and flow regulators and appropriate fittings
 - Torch for gas shielded automated welding
 - Basic Weld Prep Tools
2. Cable Connections
 - Connect welding torch conduit cable to wire feeder
 - Connect Weld Contactor lead from Torch to Main Cable Connector on machine body
 - Connect Control Cable to the Control Box Connector on the machine body
 - Connect Control Power Source Cable to the Welding Power Source

CAUTION: Carefully route power cable as it may become entangled during operation, resulting in damage to people or equipment.
3. Welding Process
 - Switch ON the Primary Side Distribution Board of the Welding Power Source
 - Switch ON the Control Power Source on the front panel of the Welding Power Source
 - Equip the Wire Feeder with wire
 - Set the Carriage so the torch is at the weld starting point
 - Install the Guide Arms offset in the direction of travel (leading arm slightly shorter than following arm) for better positioning of the electrode in the joint
 - Adjust the target angle and position of the Torch using the Torch Adjustment Slider
 - Verify machine is in the proper welding mode. Set stitch welding parameters, if needed
 - Verify adequate Shielding Gas Supply
 - Start Welding - Switch Welding Switch to AUTO, verify desired travel direction is set and travel speed is > 0 and press Cycle Start button
 - Press Cycle Stop button when welding is complete. Turn Welding Switch to OFF
 - Confirm Welding End

MAINTENANCE

The K-BUG carriage should be periodically checked and cleaned to maximize service life.

Before use:

Check all screws in the torch clamp and guide rollers. Tighten as needed. Loose fasteners may cause uneven travel or inconsistent weld quality.

During use:

Monitor wheels, motor and welding torch for abnormal noise or overheating.

After each use:

1. Clean control panel to remove dust and other debris.
2. Inspect carriage base, wheels, guide rollers, slide adjustment, magnets and torch for weld spatter or other debris. Clean as needed.
3. Inspect power cable and torch cable for cracked, cut or damaged insulation. Replace as needed.
4. Inspect connectors for damaged pins or loose connections. Replace as needed.

TROUBLESHOOTING

Symptom	Cause	Repair
Control panel Display is not LIT when machine is plugged in	Disconnected Control Cable	Connect control cable to machine
	Faulty Control Cable	Replace Cable
	Control Box Fuse Tripped or Disconnected	Replace fuse. If problem persists, contact service rep.
No Arc when Welding Auto/Off Switch turned to AUTO	Weld Auto/Off Switch set to OFF	Turn Weld Auto/Off Switch to AUTO
	Loose contact of Welding Leads	Check ground connections. Verify good contact on clean, unpainted surface.
	Faulty or incorrectly wired Welding Auto/Off Switch	Check Wiring. Replace Switch, if needed
	Stop Sensor does not detect work piece.	Reposition carriage so Stop Sensor is over work piece.
Carriage does not travel when Cycle Start Button is pushed	Failed drive component	Check Motor, Drive Chain and Gearbox. Replace as needed
	Faulty or incorrectly wired Cycle Start Button	Check Wiring. Replace button , if needed
	Faulty MAIN PCB	Replace MAIN PCB
Torch targets wrong position	Loose fastener on Torch Clamp or Slide Assembly	Check and tighten screws, replace if needed.
Slide is hard to adjust	Dust or other debris on slide parts	Clean slide parts. Lubricate with light oil
Carriage stops during automatic welding	Obstacle in carriage path	Remove obstacles
	Carriage is at end of work piece. Stop Sensor doesn't detect work piece.	Reposition carriage so Stop Sensor is over work piece.
	Distance traveled exceeds Total Length	See "Intermittent Welding" on page 7 for instructions to set Total Length
Arc continues after Welding Auto/Off Switch is set to OFF	The Welding Auto/Off Switch is still set to Auto	Turn Weld Auto/Off Switch to OFF
	Faulty or incorrectly wired Welding Auto/Off Switch	Check Wiring. Replace Switch, if needed.
Unable to perform Intermittent Welding	Intermittent Welding is locked	Press and hold Travel Speed Adjustment knob for 3 seconds.

TROUBLESHOOTING, CONT'D.

K-BUG ERROR LIST

NO.	SYMPTOM	CAUSE	SOLUTION
E-03	Motion Stop	Main PCB EET ROM Error	Main PCB Replacement
E-05	Travelling Stop	Auto-Stop Travelling Motor may be overloaded / shorted	Push and release Stop Button IF UNRESOLVED: 1. Check for loose wiring connection at drive motor and weave motor if equipped (see below). 2. Replace motor or motor reducer 3. Replace main PCB

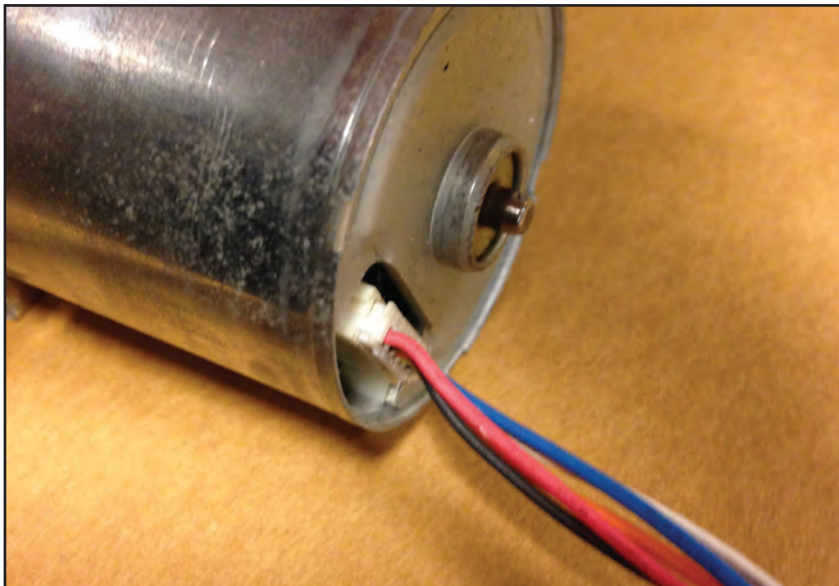
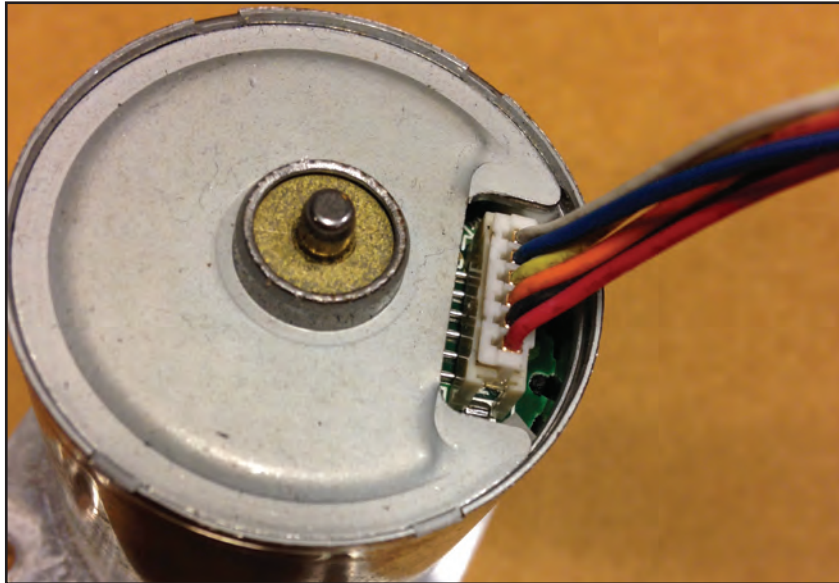

K-BUG 4000 ASSEMBLY VIEW

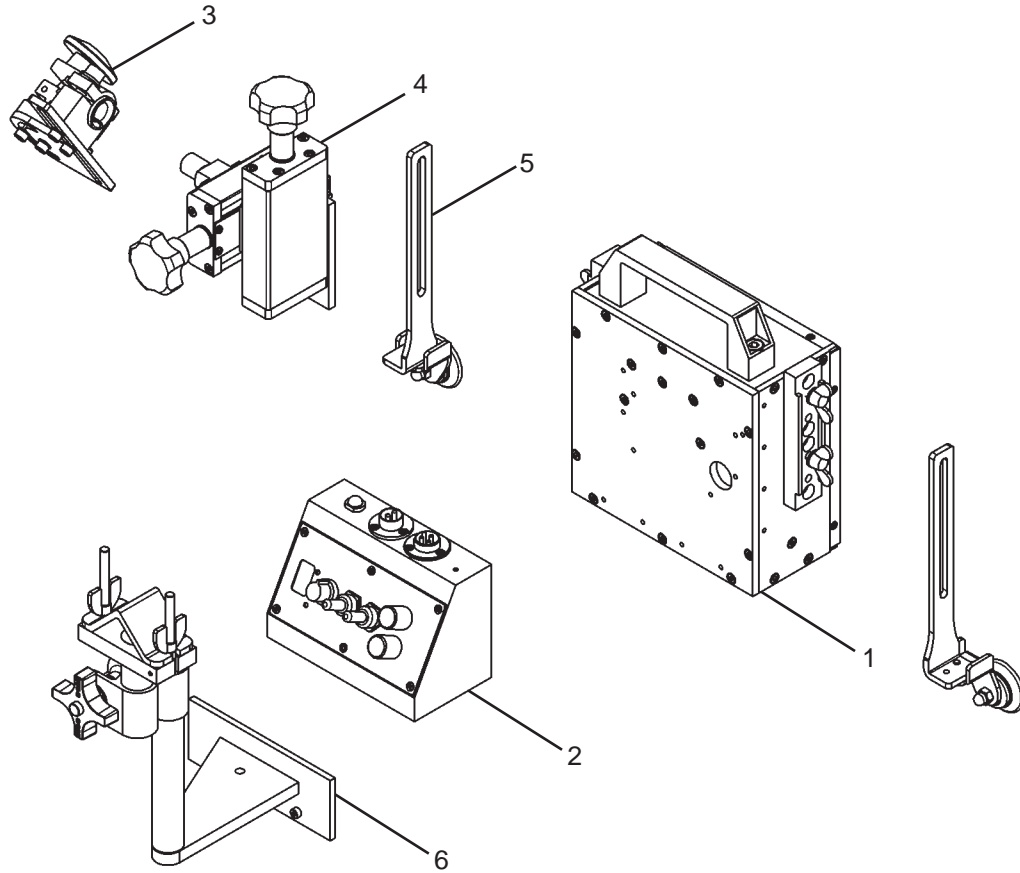

<u>ITEM</u>	<u>QTY</u>	<u>PART NO.</u>	<u>DESCRIPTION</u>
1	1	KBUG-4010	Carriage Assembly
2	1	KBUG-4050	Control Panel Assembly
3	1	KBUG-4090	Torch Clamp Assembly
4	1	KBUG-4070	Slide Assembly
5	1	KBUG-1060	Guide Arm Assembly
6	1	KBUG-4040	Cable Anchor
*	1	KBUG-2274-XX	120 VAC Power Cord
*	1	KBUG-2273-XX	Weld Contact Cable
*	1	KBUG-1003	Metric Hex Key Set

* = Not shown

Note:

1. XX = Cable length: 15, 25, 50 ft (4.5, 7.5, 15 m)
2. For KBUG-4002, Power Cord is KBUG-2272-15.

K-BUG 4000 WIRING DIAGRAM

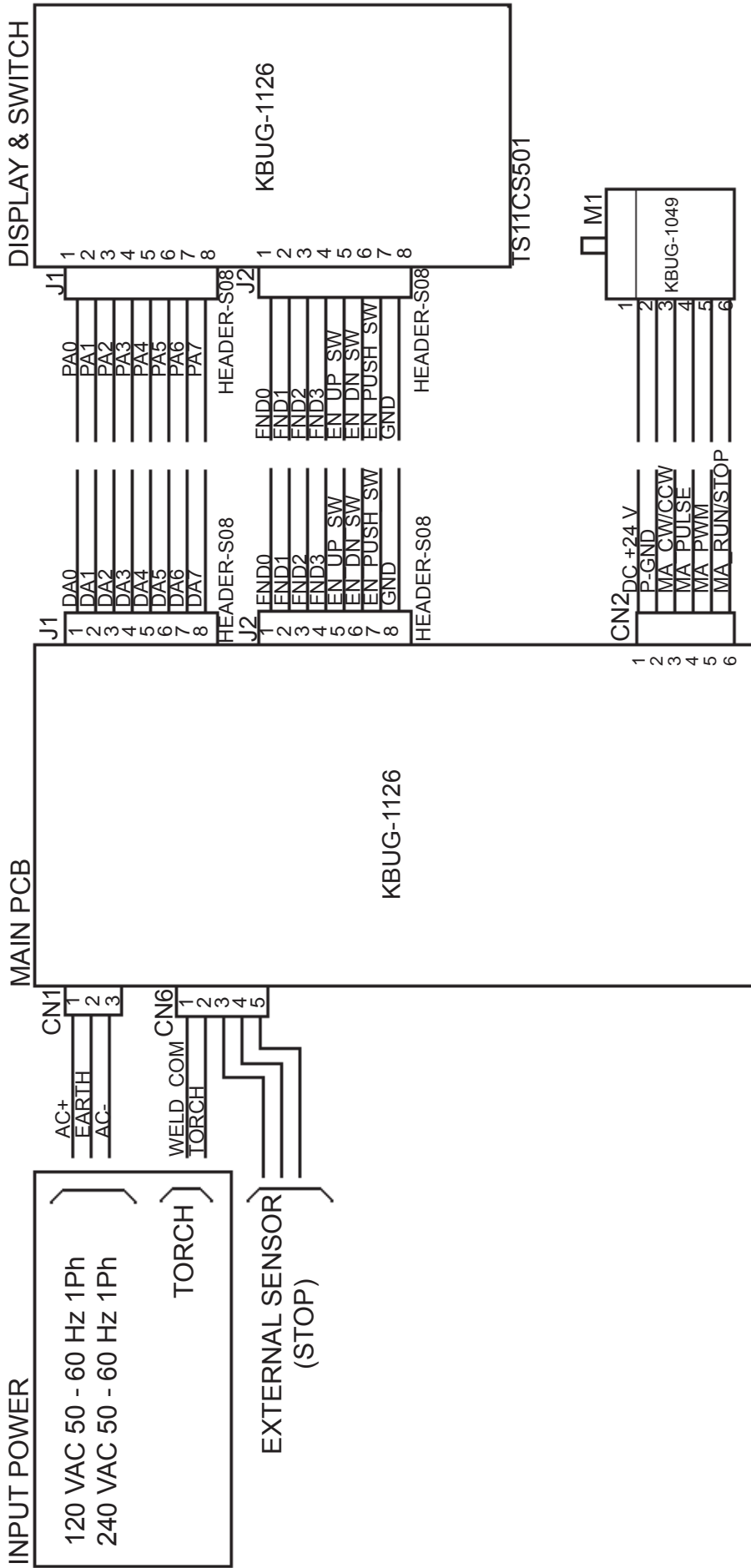

KBUG-4010 CARRIAGE ASSEMBLY / EXPLODED VIEW

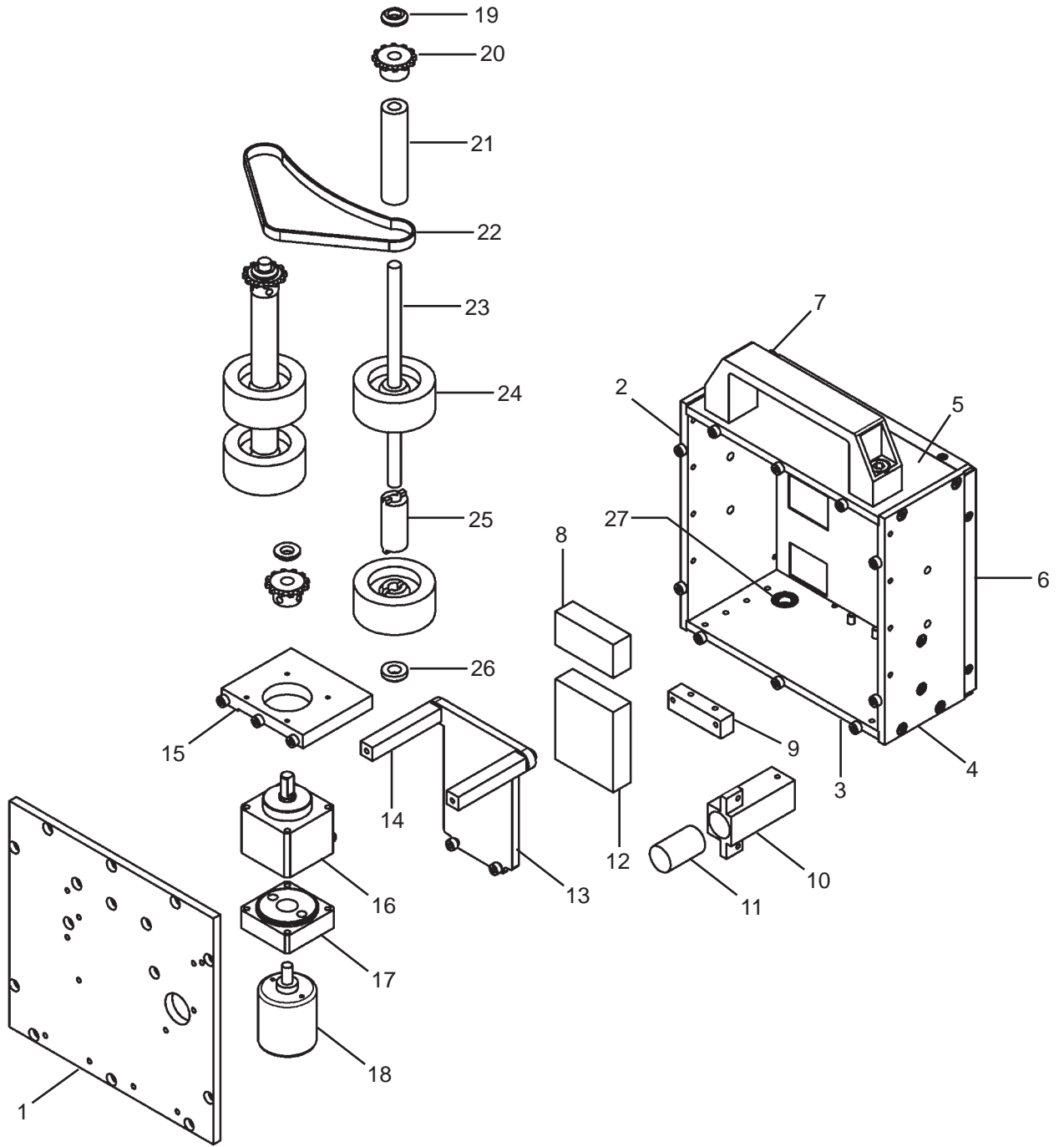

KBUG-4010 CARRIAGE ASSEMBLY / PARTS LIST

<u>ITEM</u>	<u>QTY</u>	<u>PART NO.</u>	<u>DESCRIPTION</u>
1	1	KBUG-4011	Body, Rear
2	1	KBUG-4012	Body Side, Left
3	1	KBUG-4013	Body, Bottom
4	1	KBUG-4014	Body Side, Right
5	1	KBUG-4015	Body, Top
6	1	KBUG-4028	Body Cover
7	1	KBUG-4032	Handle
8	1	KBUG-4027	Magnet, Small
9	1	KBUG-4024	Magnet Bracket (1)
10	1	KBUG-4029	Sensor Cover
11	1	KBUG-4031	Sensor
12	1	KBUG-4034	Magnet, Large
13	1	KBUG-4026	Magnet Plate
14	2	KBUG-4025	Magnet Bracket (2)
15	1	KBUG-4023	Motor Bracket (BD)
16	1	KBUG-4037	Geared Motor
17	1	KBUG-4038	Motor Bracket (BLDC)
18	1	KBUG-1049	DC Brushless Motor
19	3	KBUG-4021	Wheel Shaft Bushing (2)
20	3	KBUG-4035	Chain Sprocket
21	2	KBUG-4017	Wheel Shaft Cover (1)
22	1	KBUG-4022	Chain
23	2	KBUG-4016	Wheel Shaft
24	4	KBUG-1036	Wheel, 50mm
25	2	KBUG-4018	Wheel Shaft Cover (2)
26	2	KBUG-4019	Wheel Shaft Bushing (1)
27	4	KBUG-4036	Roller Bearing

KBUG-1060 GUIDE ARMS / EXPLODED VIEW / PARTS LIST

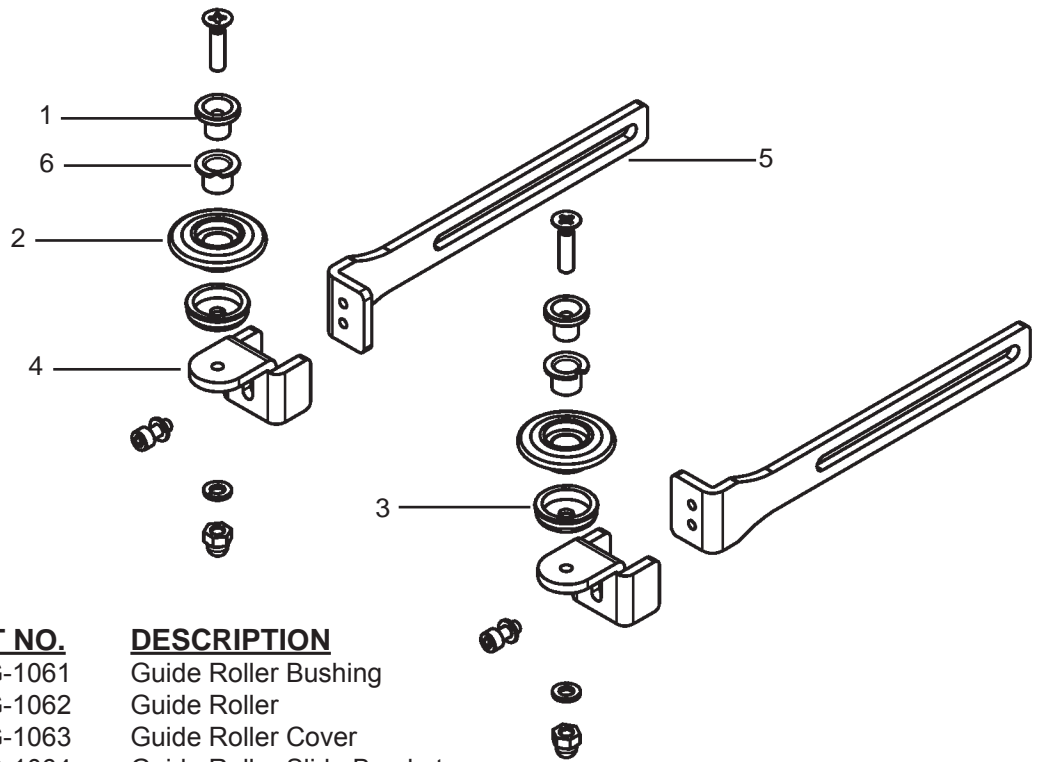

<u>ITEM</u>	<u>QTY</u>	<u>PART NO.</u>	<u>DESCRIPTION</u>
1	2	KBUG-1061	Guide Roller Bushing
2	2	KBUG-1062	Guide Roller
3	2	KBUG-1063	Guide Roller Cover
4	2	KBUG-1064	Guide Roller Slide Bracket
5	2	KBUG-1065	Guide Arm
6	2	KBUG-1068	Guide Roller Sleeve

KBUG-4090 TORCH CLAMP ASSEMBLY / PARTS LIST

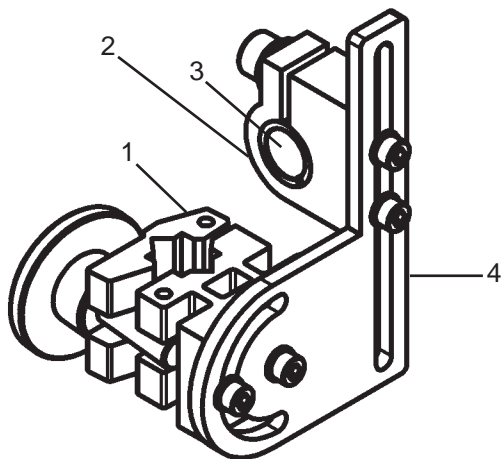

<u>ITEM</u>	<u>QTY</u>	<u>PART NO.</u>	<u>DESCRIPTION</u>
1	1	KBUG-2080	Torch Clamp Assembly
2	1	KBUG-4095	Slide Bar Clamp
3	1	KBUG-3076	Bushing
4	1	KBUG-4097	HDH-Torch Clamp Base

KBUG-4050 CONTROL PANEL ASSEMBLY / EXPLODED VIEW / PARTS LIST

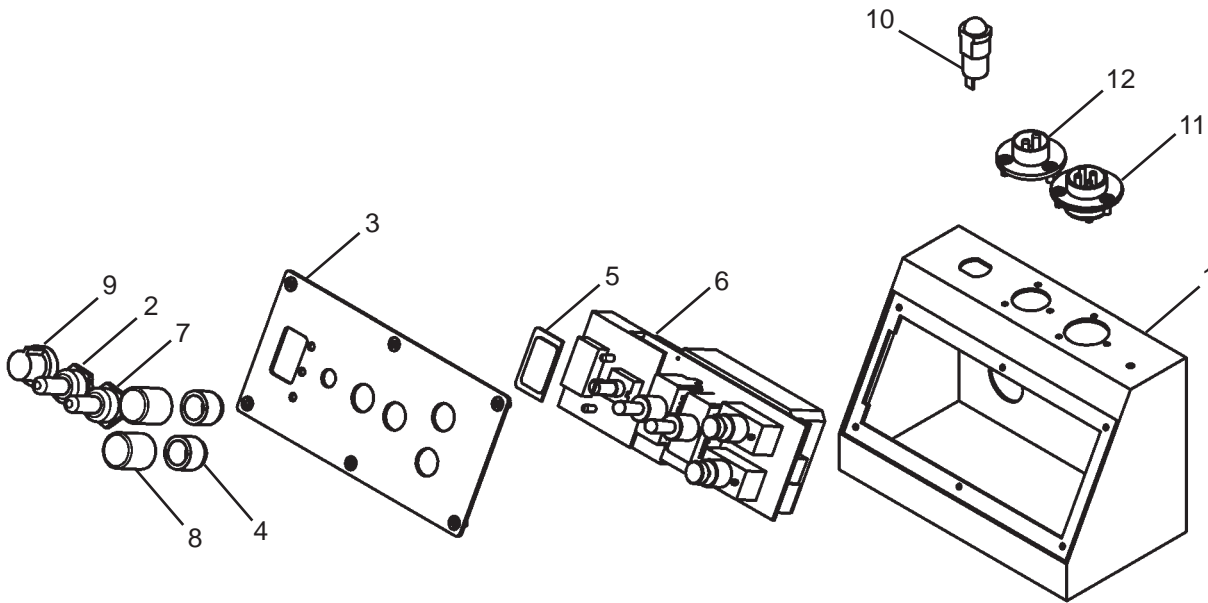

<u>ITEM</u>	<u>QTY</u>	<u>PART NO.</u>	<u>DESCRIPTION</u>
1	1	KBUG-4051	Panel
2	2	KBUG-1122	Toggle Switch Cover
3	1	KBUG-1123	Legend Plate
4	2	KBUG-1124	Push Button Cover (BS)
5	1	KBUG-1125	Display
6	1	KBUG-1126	Main PCB
7	1	KBUG-1127	Push Button Cover - 2
8	1	KBUG-1128	Push Button Cover -1
9	1	KBUG-1129	Volume Knob
10	1	KBUG-1131	Fuse Holder w/ Fuse
11	1	KBUG-1132	Power Connector, 4T (Female)
12	1	KBUG-1133	Torch Connector, 2T (Female)
*	1	KBUG-1173	Weld Contact Connector (Male)
*	1	KBUG-1174	Power Connector (Male)

* Not Shown

ACCESSORIES

KBUG-1067 Magwheel Add-On Kit

Magnetic guide wheels available for curved or irregular seams.

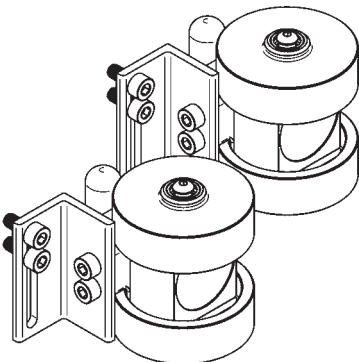

SBG-450- - - GUN & CABLE ASSEMBLY / EXPLODED VIEW / PARTS LIST

Whip Length: 15 (15 ft / 4.6 m) or 25 (25 ft / 7.6 m)
 Wire Size: 035, 040, 045, 052, 116, 564
 Connector Type: E (Euro), L (Lincoln 3/4"), M (Miller), T (Lincoln, small)

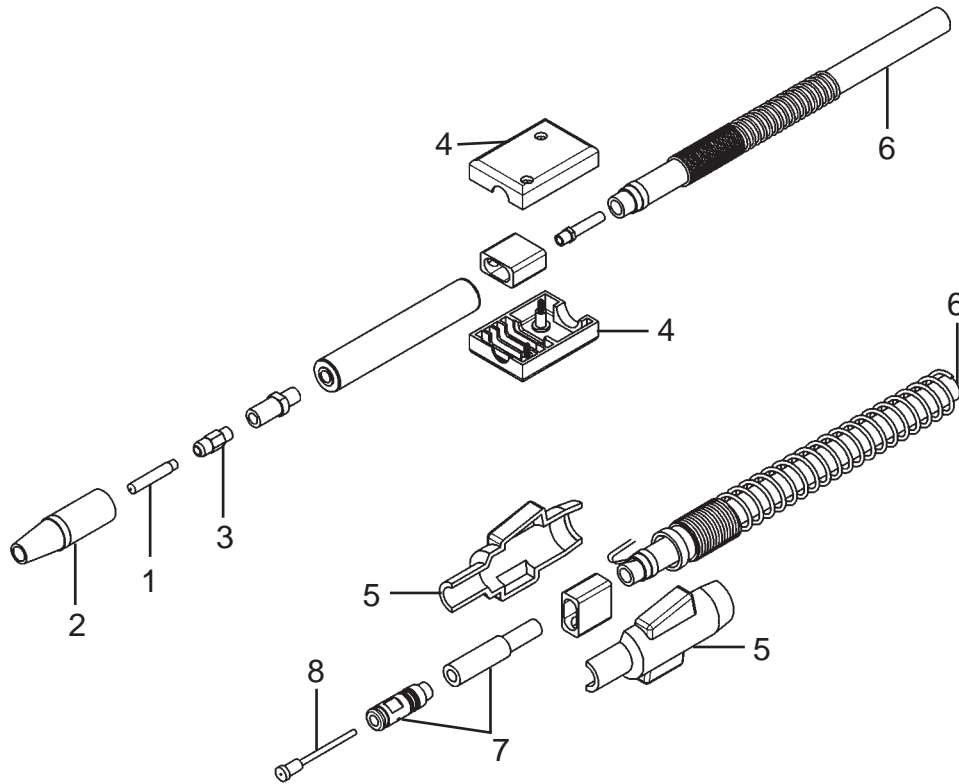

PARTS LIST				WIRE SIZE					
ITEM	QTY	PART NO.	DESCRIPTION	.035 (.9 mm)	.040 (1.0)	.045 (1.2)	.052 (1.4)	1/16 (1.6)	5/64 (2.0)
1	1	BUG-3159-35	16S-35 (.9 mm) Contact Tip	X					
1	1	BUG-3159-45	16S-45 (1.2 mm) Contact Tip			X			
1	1	BUG-3159-52	16S-52 (1.4 mm) Contact Tip				X		
1	1	BUG-3159-116	16S-116 (1.6 mm) Contact Tip					X	
1	1	BUG-3159-564	16S-564 (2.0 mm) Contact Tip						X
1	1	PWS-4436-1.0	16S-40 (1.0 mm) Contact Tip		X				
2	1	PWS-4447	27S62 H.D. Nozzle 5/8"	X	X	X	X	X	X
3	1	PWS-4449	PX57HD Gas Diffuser	X	X	X	X	X	X
4	1	CWO-8017	Case w/ Binder Screws (Front)	X	X	X	X	X	X
5	1	PWS-4411	Case w/ Binder Screws (Back)	X	X	X	X	X	X
6	1	STW-3044	450 Amp Cable	X	X	X	X	X	X
7	1	R174-T	Connector, Small Lincoln						
7	1	R174-L	Connector, 3/4" Lincoln						
7	1	R174-M	Connector, Miller						
7	1	R174-X	Connector, Euro						
8	1	CWO-8009	44-3545-15 Cable Liner	X	X	X			
8	1	CWO-8011	44-116-15 Cable Liner				X	X	
8	1	CWO-8012	44-564-15 Cable Liner						X
**	1	SBG-1004	Gas Hose Assembly	X	X	X	X	X	X
**	2	SBG-1005	Gas Hose Clamps	X	X	X	X	X	X

** Not shown. Required only with standard Lincoln guns (SBG-450-L).

WARRANTY

LIMITED WARRANTY

MODEL _____
SERIAL NO. _____
DATE PURCHASED: _____

FOR A PERIOD OF TWELVE (12) MONTHS FROM DELIVERY, BUG-O SYSTEMS WARRANTS TO THE ORIGINAL PURCHASER (DOES NOT INCLUDE AUTHORIZED DISTRIBUTORS), THAT A NEW MACHINE IS FREE FROM DEFECTS IN MATERIAL AND WORKMANSHIP AND AGREES TO REPAIR OR REPLACE, AT ITS OPTION, ANY DEFECTIVE PARTS OR MACHINE. THIS WARRANTY DOES NOT APPLY TO MACHINES, WHICH AFTER OUR INSPECTION, ARE DETERMINED TO HAVE BEEN DAMAGED DUE TO NEGLIGENCE, ABUSE, OVERLOADING, ACCIDENT OR IMPROPER USAGE. ALL SHIPPING AND HANDLING CHARGES WILL BE PAID BY CUSTOMER.

BUG-O SYSTEMS MAKES NO WARRANTY OF MERCHANTABILITY AND MAKES NO OTHER WARRANTY, EXPRESSED OR IMPLIED, BEYOND THE WARRANTY EXPRESSLY SET FORTH ABOVE. BUYER'S REMEDY FOR BREACH OF WARRANTY, HEREUNDER, SHALL BE LIMITED TO REPAIR OR REPLACEMENT OF NON-CONFORMING PARTS AND MACHINES. UNDER NO CIRCUMSTANCES SHALL CONSEQUENTIAL DAMAGES BE RECOVERABLE.

HOW TO OBTAIN SERVICE:

IF YOU THINK THIS MACHINE IS NOT OPERATING PROPERLY, RE-READ THE INSTRUCTION MANUAL CAREFULLY, THEN CALL YOUR AUTHORIZED BUG-O DEALER/DISTRIBUTOR. IF HE CANNOT GIVE YOU THE NECESSARY SERVICE, WRITE OR PHONE US TO TELL US EXACTLY WHAT DIFFICULTY YOU HAVE EXPERIENCED. BE SURE TO MENTION THE MODEL AND SERIAL NUMBERS.