

Fixturing Equipment From Bug-O Systems



Operator Controlled
Mechanization

www.bugo.com

Bug-O Systems is committed to empowering our customers by providing operator controlled mechanized solutions for their welding, cutting and custom applications.



Fixturing Equipment

Torch Supports Freestanding Torch Support FTS-1020



FTS-1020 shown above.

The **Freestanding Torch Support FTS-1020** is a small manually operated torch manipulator. Rack and pinion movement on hardened "V" ways provides effortless and smooth positioning of cutting torch or welding gun. The "T" base comes with pre-drilled holes for quick installation into your fixture.

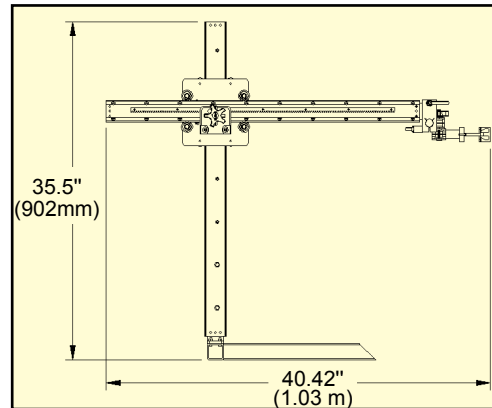

Total Vertical Adjustment: 25" (635 mm)

Total Horizontal Adjustment: 25" (635 mm)

Net Weight: 35 lbs. (11.34 kg)

Freestanding Torch Support

FTS-1025 110 volt FTS-1025-240 240 volt



Application of FTS-1025 Automatic Height Control with Linear Weaver shown above.

The NEW **FTS-1025 Free Standing Torch Support with Automatic Height Control** is a compact, easy to use system, designed to maintain a constant torch-to-work distance automatically. This system can be used for Sub-Arc, Innershield and MIG welding. The actual weld current is sensed continuously using a shunt. The signal is filtered, amplified and compared to a set point value. Any error from the set point is noticed by the controller and it will raise the torch up or down to maintain precise torch to work distance automatically.

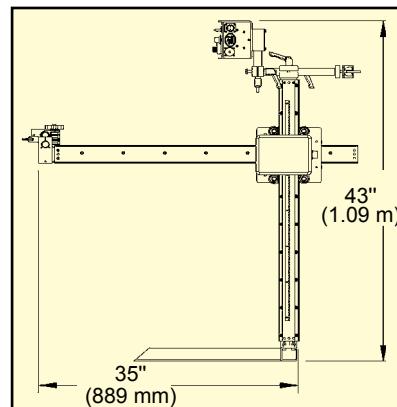

Total Vertical Adjustment: 25" (635 mm)

Total Horizontal Adjustment: 25" (635 mm)

Net Weight: 41 lbs. (19 kg)



Fixturing Equipment

Mini-Minipulator BUG-1965

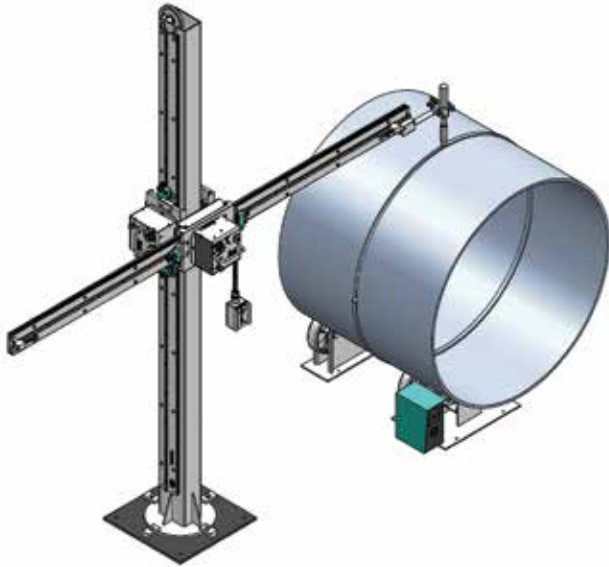

The MINI-MINIPULATOR II includes solid state variable speed, vertical and horizontal DC drives, pendant control of "up-off-down" and "forward-off-reverse," limit switches on both drives, and a counterweight in column center. The base rotates 360 degrees.



TECHNICAL DATA:

Specifications:

Power Requirement:

BUG-1965	120 VAC/50-60/1
BUG-1966	220 VAC/50-60/1
BUG-1967	42 VAC/50-60/1

Vertical Travel: 65" (1651 mm)

Minimum Height: 21-1/2" (546 mm)
From Centerline of Horizontal Rail to Mounting Surface (Floor)

Maximum Height: 86-1/2" (2197 mm)

Horizontal Travel: 64" (1626 mm)
Measured from Centerline of Column to End of Horizontal Rail

Load Capacity: 20 lbs. (10kg)

Net Weight: 420 lbs. (191 kg)

Shipping Weight: 500 lbs. (227 kg)

Dimensions: 93-1/2"L x 15"W x 100"H
(2375 mm x 380 mm x 2540 mm)

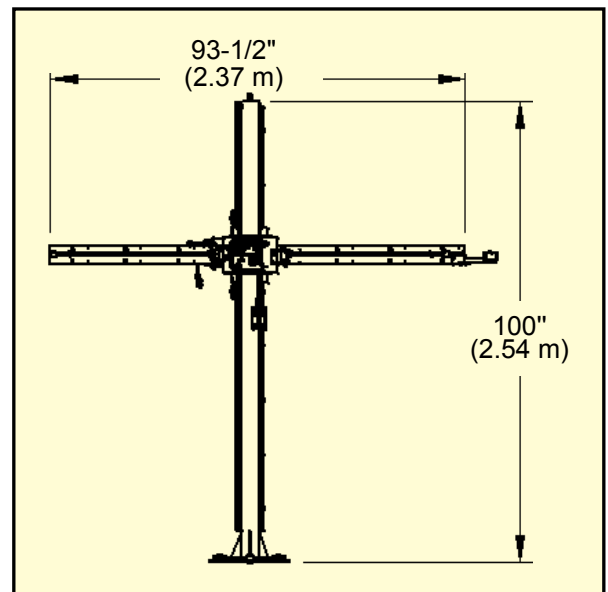



Fixturing Equipment - Weavers

The Stand Alone Weavers are compact lightweight oscillating weld weavers designed to be mounted on Manipulators and Fixtures. They offer the ability to perform weave welds or straight-line stringer welds and can be used to steer the torch during welding operations. They also feature adjustable independent dwell settings for controlled penetration and undercut elimination.



CDS-6350
Stand Alone Linear Weaver



BUG-6350
Stand Alone Pendulum Weaver

TECHNICAL DATA:

Specifications:

Power Requirement:

CDS-6350 120 VAC/50-60 Hz
CDS-6352 240 VAC/50-60 Hz
CDS-6354 42 VAC/50-60/1

Weave Speed: 4-100 ipm (102-2540 mm/min)

Dwell: 0-3 seconds each side

Weave Width: 0-2" (0-50 mm)

Steering: 4" - 2" (100-50 mm)
each side of center

Net Weight: 17 lbs. (7.7 kg)

Weaver Dimensions: 6.75"L x 5.00"W x 3.88"H
(171 x 127 x 99 mm)

TECHNICAL DATA:

Specifications:

Power Requirement:

BUG-6350 120 VAC/50-60 Hz
BUG-6352 240 VAC/50-60 Hz
BUG-6354 42 VAC/50-60/1

Weave Speed: 4-200 ipm (102-5100 mm/min)

Dwell: 0-3 seconds each side

Weave Width: 0-2" (0-50 mm)

Steering: 4" - 2" (100-50 mm)
each side of center

Net Weight of System: 21 lbs. (9.5 kg)

Weaver Dimensions: 5.50"L x 3.00"W x 4.00"H
(139 x 76 x 120 mm)

