



DCW-5-L

CIRCLE WELDER



412-331-1776 www.bugo.com

Bug-O Systems is guided by honesty, integrity and ethics in service to our customers and in all we do.





DCW-5-L (DCW-1500-L) Circle Welder

Features:

- Power Feed 84® Wire feeder control
- Wire feeder with one set of drive rolls
- P.M. motor and speed control for rotation with digital readout
- Gun and cable assembly
- Burnback control
- 50 ft. (15 m) control cable and gas hose
- Quick disconnects for welding lead
- Weld switch
- Cold wire inch switch
- Wire direction switch
- Pre and post flow included
- Wire reel adaptor for 30 lbs. (14 kg) spools
- Vertical and horizontal adjustment rack and pinion
- Rise and fall cam with 5" (125 mm) of movement
- Brushes and collector rings for welding current, rated at 300 amps 100% duty cycle
- Emergency stop
- Overlap
- Return to start position

Technical Data:

- Current Rating:** 0-300 amps, 100% duty cycle
- Input Voltage:** Rotational 115 VAC
- Wire Sizes:** .025-.120" (0.6 - 3.0 mm)
- Rise and Fall Cam:** 5" (125 mm)
- Rotation Speed:** .5-5.9 rpm
- Welding Diameter:** 1-12" (25-300 mm)
- Height:** 29" (737 mm)
- Net Weight:** TBD

The DCW-5-L may be used with Lincoln Electric® S350 or S500 power source (see page 3).

Options:

- CWO-1645 Pendulum Type Oscillator
Variable Speed Mechanical
 - CWO-3670 Step Adaptor
1/2-4" (13-102 mm) couplings.
 - CWO-4530 Carriage with lever.
 - CWO-4540 Carriage with winch.
 - CWO-4550 Carriage with motorized lift
- Motorized racking is available.
Water cooling package for water cooled gun is available.

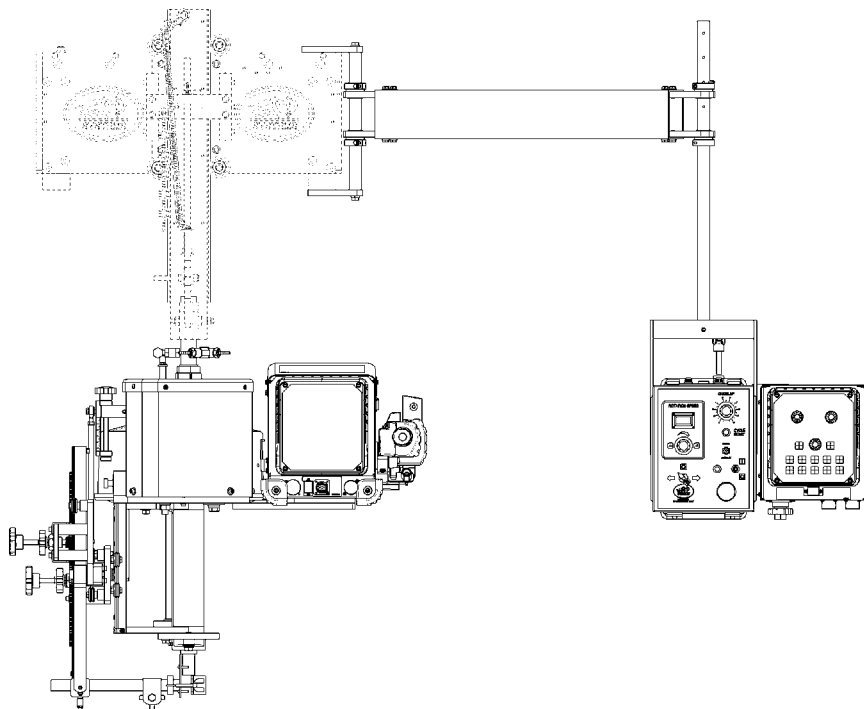



DCW-5-L Circle Welder



Power Wave S350 / S500

PowerConnect™ Technology (Patent-Pending) – Automatically adjusts to input power from 200-600V, 50 or 60 Hz, single phase or three phase. Welding output remains constant through the entire input voltage range.

Tribrid™ Power Module – Exceptional welding performance with high power factor and efficiency.

CheckPoint™ – A cloud-based data collection tool allows customers to view and analyze welding data on almost any device – desktop, laptop, iPhone® or iPad®, Blackberry® and others. Track equipment usage, store weld data, configure fault limits and more.

Optional 115V (10A) AC Duplex Auxiliary Power Receptacle – Features patent-pending Surge Blocker™ Technology to ensure simultaneous welding performance is not compromised by high starting current devices such as grinders (typically requiring 60A or more peak surge current).

Compact and Durable Case – IP23 rated to withstand harsh environments.

Standard Ethernet – Allows for effortless software upgrades through powerwavesoftware.com

S350 Specifications

Product Name	Product Number	Input Voltage	Input Current @ Rated Output	Rated Output Current/Voltage/Duty Cycle	Output Range ⁽³⁾	H x W x D Inches (mm)	Net Weight lbs. (kg)
Power Wave® S350	K2823-3	208/230/380-415/460/575/1/3/50/60	3 Ph / 40% Duty Cycle: 39/35/19/17/14 3 Ph / 100% Duty Cycle: 31/28/15/14/11 1 Ph / 40% Duty Cycle: 60/67 ⁽¹⁾ /NA/NA/NA 1 Ph / 100% Duty Cycle: 60/53/NA/NA/NA	GMAW: 350A/31.5V/40% ⁽²⁾ GMAW: 300A/29V/100% SMAW: 325A/33V/40% ⁽²⁾ SMAW: 250A/30V/100% GTAW-DC: 350A/24V/40% GTAW-DC: 300A/22V/100%	5-350A	20.40 x 14 x 24.80 (518 x 356 x 630)	85 (38.6)
Power Wave® S350 Ready-Pak® (Steel)	K3005-3					52 x 39 x 26 (1321 x 991 x 660)	450 (204.1)

S500 Specifications

Product Name	Product Number	Input Voltage	Input Current @ Rated Output	Rated Output Current/Voltage/Duty Cycle	Output Range	H x W x D Inches (mm)	Net Weight lbs. (kg)
Power Wave® S500	K2904-1	200/208/220/230/380/	3 Ph / 40% Duty Cycle: 80/73/41/37/29	GMAW: 550A/41.5V/40%	5-550A	22.5 x 14 x 24.8	150
Power Wave® S500/ Power Feed® 84 Ready-Pak®	K3187-2	400/415/460/575/ 3/50/60	3 Ph / 100% Duty Cycle: 60/54/30/27/21	GMAW: 450A/36.5V/100% SMAW: 550A/42V/40% SMAW: 450A/38V/100%		(571 x 355 x 630)	(68)
Power Wave® S500/ Power Feed® 84 One-Pak®	K3186-2			GTAW-DC: 550A/32V/40% GTAW-DC: 450A/28V/100%			



DCW-5-L Circle Welder

Lincoln Electric® Power Feed® 84

Recommended Power Sources:

Power Wave® 455 M
Power Wave 455 M/STT®
Power Wave S350
Power Wave S500
Power Wave S700

Input Power: 40 VDC
**Output Capacity
Current/Duty Cycle:** 600A/60%
Wire Size Range: .025-.120 in. (0.6 - 3.0 mm)⁽³⁾
Wire Feed Speed: 50-1200 (1.3-30.4)⁽¹⁾⁽²⁾
**Weight/Dimensions
(H x W x D):** 25.2 x 15.5 x 27.9
(640 x 394 x 709)
single wire drive

Simple & Customizable Controls –

- New Auto-Settings simplify process setup
- Eight User Memories – Per feed head for complete welding procedure recall
- USB Port – Simplifies machine setup and expands user profiles
- User Interface – Can be customized to display customer specific information
- Contactor and gouge kit isolate the feedheads for additional safety

Rugged Design –

- Improved isolation & environmental protection
- Robust connection points allow for reliable operation in tough conditions

Modular Platform

- Modularity ensures the feeder can be configured to fit a variety of application needs

Key Controls



1. Amperage and voltage displays
2. Mode selection and customizable process display
3. Process configuration menus
4. Dual procedure setup
5. Feed head selection
6. User memory selection
7. USB port
8. 12 pin remote connection
9. Gun trigger connector (5 pin amphenol)
10. Cold feed and gas purge